

2021 SELF-STUDY REPORT

Part 1: Our Programs



Laboratory Medicine & Pathobiology
UNIVERSITY OF TORONTO

Temerty
Medicine

“A department that offers excellent opportunities for students, staff and faculty to enjoy a productive career in academia.”

— LMP Faculty

Cover image

Postgraduate trainee, Daniel Schlam, “Mac Attack”, LMP Art Competition 2021 winner

Design

Green Living Enterprises



Laboratory Medicine & Pathobiology
UNIVERSITY OF TORONTO

2021 Self-Study Report

Part 1: Our Programs

Temerty
Medicine



PARTI

OUR

PROGEN



○
○

RAMS

Glossary of Abbreviations

A&S	The Faculty of Arts and Science at the University of Toronto	CPA	creative professional activity
AACC	American Association for Clinical Chemistry	CPC	Concepts, Patients and Communities course
ABCC	American Board of Clinical Chemistry	CPD	Continuing Professional Development
AFC	Area of focused competence	CPSO	College of Physicians and Surgeons of Ontario
AHD	Academic Half Day	CQI	continuous quality improvement
AI	Artificial Intelligence	CRC	Conflict Resolution Centre
AP	Anatomical Pathology	CRC	Canada Research Chair
ARC	TRP Anti-Racism Committee	CSCC	Canadian Society of Clinical Chemists
ARCDO	Anti-Racism and Cultural Diversity Office	CV	Curriculum Vitae
ART	assisted reproductive technology	DAC	Department Appointments Committee
ASC	Academic Success Centre	DCM	Division of Comparative Medicine
ASCP	American Society for Clinical Pathology	ddPCR	Droplet Digital Polymerase Chain Reaction
CACB	Canadian Academy of Clinical Biochemistry	DDS	Doctor of Dental Surgery
CanMEDS	a framework that identifies and describes the abilities physicians require established by the RCPSC	DLM	Digital Laboratory Medicine Library
CANPREPP	Canada's portal for residency program promotion	DNA	Deoxyribonucleic acid
CAR	Continuing Appointment Review	DPC	The LMP Departmental Promotions Committee
CaRMS	Canadian Residency Matching Service	DRCPSC	Diplomate of the Royal College of Physicians and Surgeons of Canada
CBD	Competence by Design	DVM	Doctor of Veterinary Medicine
CBL	Case-based Learning	EDI	Equity, Diversity and Inclusion
CBME	Competency-Based Medical Education	EEE	Enriching Elective Experiences
CBS	Canadian Blood Services	EPA	Entrustable Professional Activity
CCBR	The Donnelly Centre for Cellular and Biomolecular Research	FCE	full-course equivalent
CCR	Co-Curricular Record	FOD	Foundation of Discipline (elements of Competence by Design)
CE	Clinical Embryologist	FOE	PhD Final Oral Examination
CEO	Chief Executive Officer	FoM	Faculty of Medicine (now Temerty Faculty of Medicine)
CESDL	Clinical Embryology Skills Development Laboratory	FTC	Fellowship Training Committee
cGPA	culmulative grade point average	FTEs	Full Time Equivalents
CIHR	Canadian Institutes of Health Research	GCAC	Graduate Centre for Academic Communication
CLAMPS	Confederation of Laboratory Medicine and Pathobiology Students – LMP Student Union (graduate)	GPA	Grade point average
CLTA	contract-limited term appointed	GPS	Graduate Professional Skills program
CME	Continuing Medical Education	GTA	Greater Toronto Area
CMPA	Canadian Medical Protective Association	HC	Hospital Chief
COD	Core of Discipline (elements of Competence by Design)	HIP	High Impact Practices
COI	Communities of Interest	IDP	Individual Development Plan
		IMS	Institute of Medical Sciences
		IPAC	Institute of Public Administration of Canada

ITAR	In-Training Assessment Report
ITER	In-training Evaluation Reports
KPIs	Key performance indicators
LMIG	Laboratory Medicine Interest Group
LMP	Department of Laboratory Medicine & Pathobiology
LMPSU	LMP Student Union (undergraduate)
LOA	Leave of Absence
LSF-CBL	Longitudinal Specialty-Focused Case-Based Learning
LPI	leading practices and/or innovations
MaRS	Medical and Related Sciences (Discovery District)
MCCQE	Medical Council of Canada Qualifying Examination
MD	Medical Doctor
MedSoc	The Medical Society
MOH	The Ontario Ministry of Health
MOU	Memorandum of Understanding
MPH	Master of Public Health
MSc	Master of Science
MSH	Mount Sinai Hospital
NSERC	Natural Sciences and Engineering Research Council of Canada
NSSE	National Survey of Student Engagement
OB-GYN	obstetrics and gynecology
OFPS	Ontario Forensic Pathology Service
OSCC	Ontario Society of Clinical Chemists
PA	Pathologists' Assistant
PFPU	Provincial Forensic Pathology Unit
PGME	Postgraduate Medical Education
PharmD	Doctor of Pharmacy
PhD	Doctor of Philosophy
PLI	Canadian Medical Association's Joule Physician Leadership Institute
POST	Program of Study type (code in ROSI)
POWER	Postgraduate Web Registration System
PTR	Progress Through the Ranks
QA	Quality assurance
QI	Quality improvement
RCPSC	The Royal College of Physicians and Surgeons of Canada
RE	Rotation Evaluations
REB	Research Ethics Board

ROSI	Repository of Student Information (University's Student Information System)
RPC	Residency Program Committee
RTE	Required Training Experiences
SGS	School of Graduate Studies
SHSC	Sunnybrook Health Sciences Centre
SickKids	The Hospital for Sick Children
SMH	St. Michael's Hospital (Unity Health)
SSAB	Seminar Series Advisory Board
SURE	The LMP Summer Undergraduate Research Experience
TAC	Thesis Advisory Committee
TAHSN	Toronto Academic Health Science Network
TAs	Teaching Assistants
T-CAIREM	Temerty Centre for Artificial Intelligence Research and Education in Medicine
TE	Teacher Evaluations
TGH	Toronto General Hospital (University Health Network)
THP	Trillium Health Partners
THPPA	Toronto Hospitals' Postgraduate Payroll Association
TMC	Temerty Medicine Connect
TRP	The Translational Research Program
TTD	Transition to Discipline, elements of Competence by Design
TTF	Toronto Translational Framework™
TTP	Tech Talent Pipeline
TTP	Transition to Practice, elements of Competence by Design
U of T	The University of Toronto
U15	the top 15 research universities in Canada
UHIP	University Health Insurance Plan
UHN	University Health Network
UHN-TGH	University Health Network-Toronto General Hospital
UME	Undergraduate medical education
USCAP	United States and Canadian Academy of Pathology
USRA	Undergraduate Student Research Awards
UTL	University of Toronto Library
WHMIS	Workplace Hazardous Materials Information System
WOHS	William Osler Health System

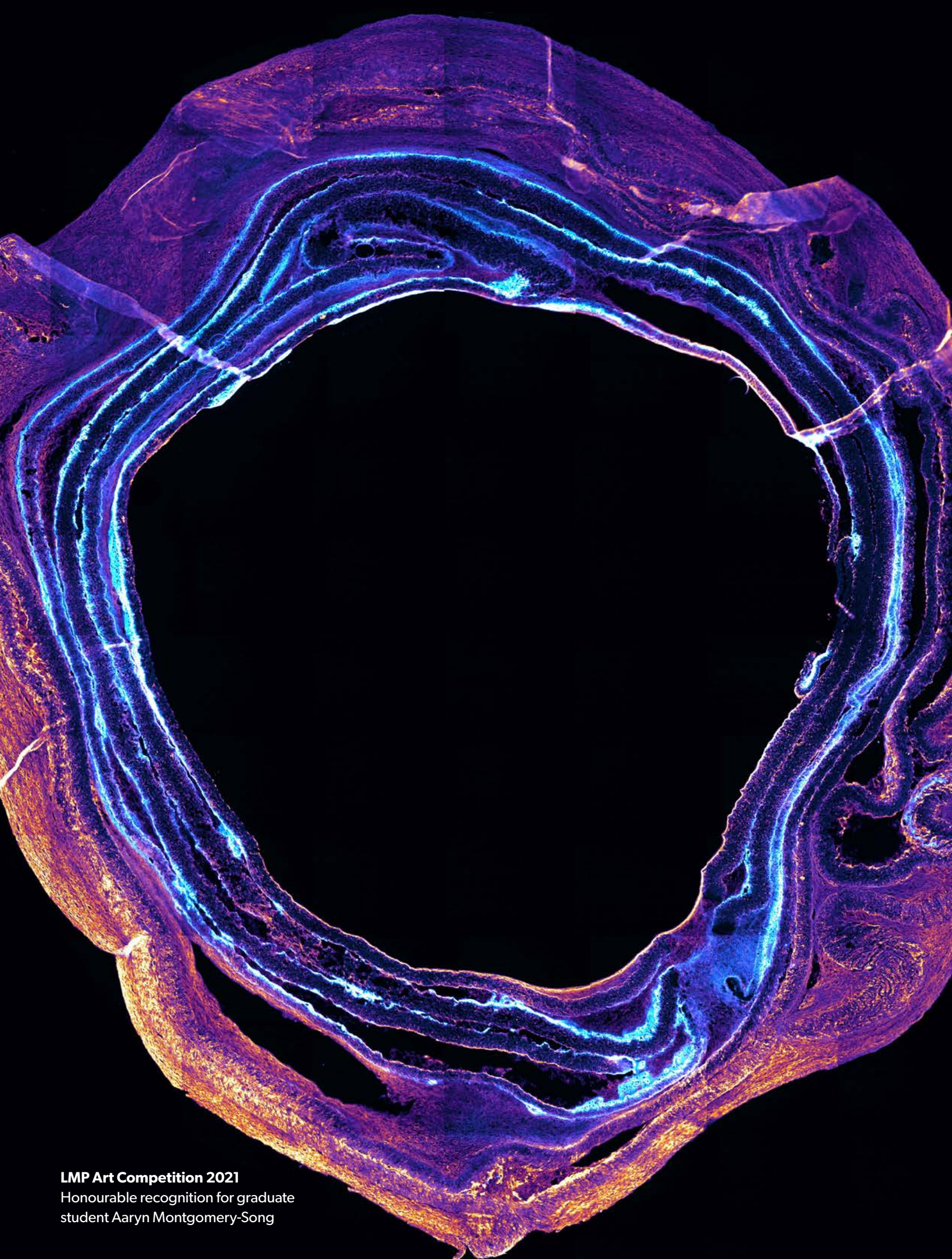

LMP Art Competition 2021
Honourable recognition for graduate
student Aaryn Montgomery-Song

Table of Contents

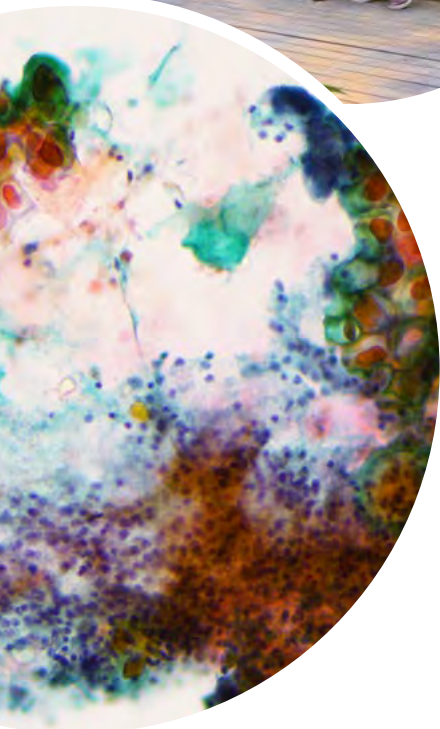

1	Introduction	10
2	Research Stream Graduate Programs	28
3	Undergraduate A&S Specialist Program in Pathobiology	46
4	MHSc in Translational Research	70
5	MHSc in Laboratory Medicine	92
6	Residency Training Programs	102
7	Postdoctoral Diploma Programs	126
8	Areas of Focused Competence	136
9	Fellowship Training Programs	142
10	Continuing Professional Development	146
11	Undergraduate Medical Education	150
12	Academic Services / Student Support Services	154

The evolution of LMP

LMP was created as a department with a dual mandate to be excellent in basic fundamental discovery science and clinical practice. As such it sits at an important intersection between discovery, applied and translational research, and clinical practice which enables a unique cross-fertilization of ideas to occur to answer questions for the benefit of individuals, patients and populations.

This is how it all came about...

1900

The University of Toronto appoints distinguished pathologist and researcher, J.J. Mackenzie, as the first Chair of Pathology.

Launches the Digital Laboratory Medicine Library

Champions the use of digital laboratory medicine, developing key strategies in education and research

1997

The clinical departments of Pathology, Clinical Biochemistry and Microbiology merge to consolidate and create the Department of Laboratory Medicine and Pathobiology (LMP), becoming the largest laboratory medicine department in Canada.

Professor Avrum I. Gotlieb, a physician-scientist, was appointed to lead the merger, create LMP and became Chair of the department.

2009

Professor Richard Hegele, is recruited from the University of British Columbia (UBC) in Vancouver to be the second LMP Chair.

Grows research space and funding

Creates the Undergraduate Specialist Program

Expands the doctoral graduate programs

Broadens the resident programs

Did you know?

Faculty and students chose the name LMP...

"Laboratory Medicine" to identify the excellence of the clinical patient care to be carried out in the teaching hospitals affiliated with Temerty Medicine.

"Pathobiology" to support and prioritize major research-intensive programs into the causes and mechanisms of human disease.

2007

An external review notes that LMP has become "A pre-eminent department on a national and broader international scenes".

LMP at a glance

Our people



445
Total LMP faculty

338
Primary faculty

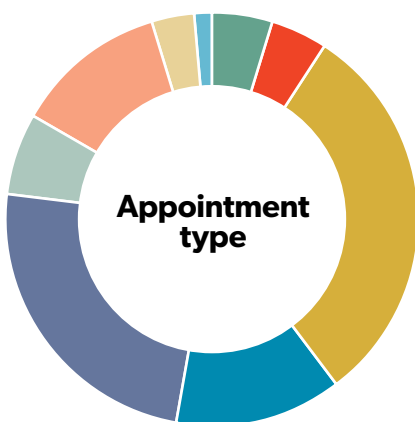
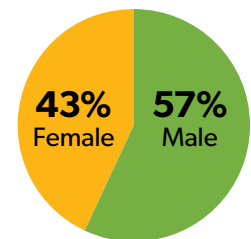

- 22 Adjunct
- 19 Clinical (MD) Adjunct Appt
- 136 Clinical (MD) Full Time Appt
- 59 Clinical (MD) Part Time Appt
- 107 Cross-appointed
- 28 PhD Researcher
- 53 Status Only
- 16 Tenure/tenure stream
- 5 Other

211
faculty have
graduate
appointments

32
Female

70
faculty promoted to
Associate Professor
and Professor
(since 2013)

38
Male



- 35 Campus
- 18 Community-Affiliated Hospitals
- 291 Fully-Affiliated Hospitals
- 51 Toronto Academic Health Science Network (TAHSN) Associate Members Affiliated Hospitals
- 50 Other LMP Affiliated Organizations

1,894
registered
LMP alumni

Education

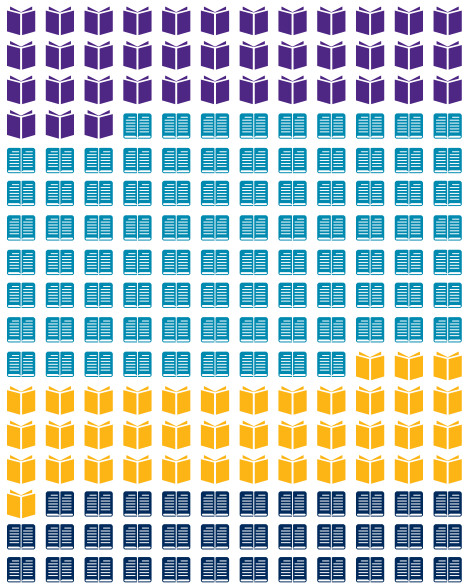

487

learners currently enrolled

93

Undergraduate

215

Graduate research
(MSc, PhD, MD/PhD)

96

Professional masters (MHSc)

83

Postgraduate



217

have attended our CPD (Continued Professional Development) events in 2021 (so far)

Research

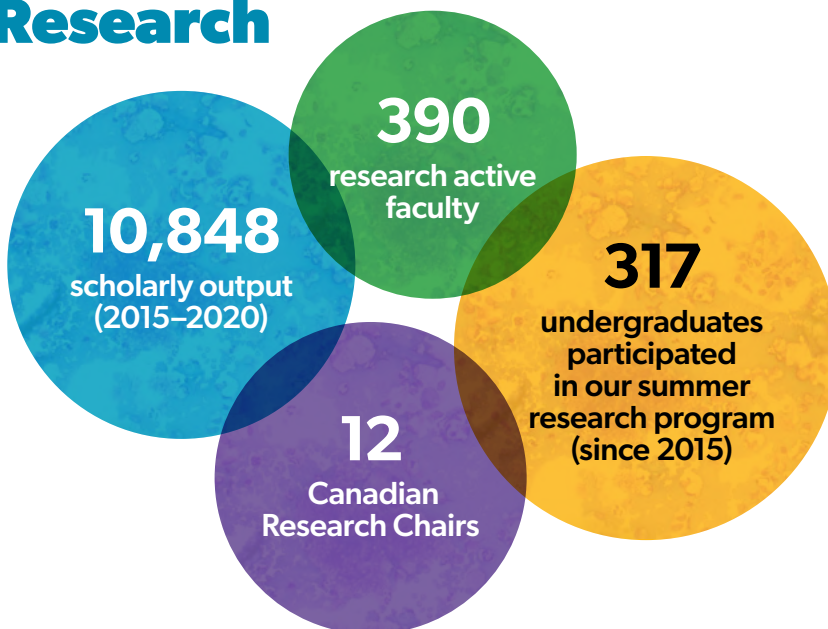

10,848
scholarly output
(2015–2020)

390
research active
faculty

317
undergraduates
participated
in our summer
research program
(since 2015)

12
Canadian
Research Chairs

11+ current Wellness, Inclusion,
Diversity and Equity initiatives

Funding

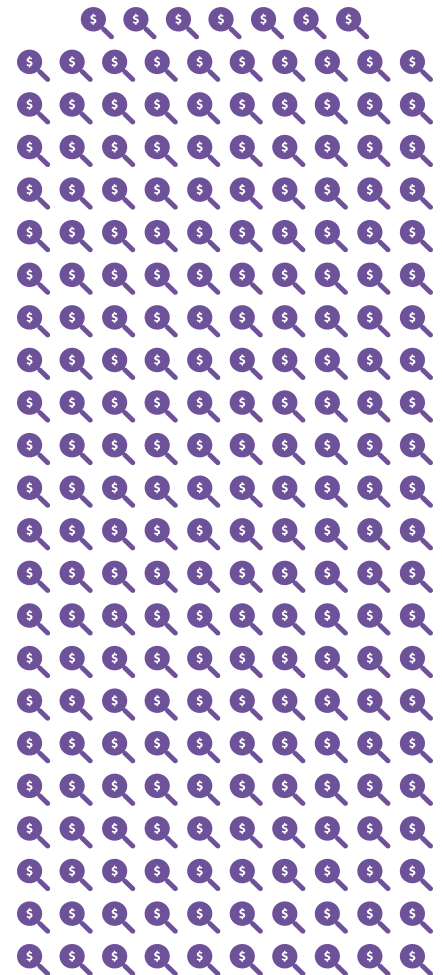

\$263,424,000

research funding (2013–2020)



\$12,614,352

funding support received by
graduate students (past 5 years)



\$4,650,000

in donations (past 5 years)

External Review terms of reference

Department under review

Dept. of Laboratory Medicine & Pathobiology

Degree programs under review

Laboratory Medicine & Pathobiology – MSc, PhD

Laboratory Medicine (Clinical Embryology/
Pathologists' Assistant) – MHS

Translational Research in Health Sciences – MHS

Pathobiology, Specialist – BSc (A&S)

Commissioning officer

Professor Trevor Young, Dean

Review dates

January 18–19, 2022

The terms of reference are intended to establish the parameters of the external review process and to provide the framework of the review report. Using the interactive form provided, reviewers are asked to comment explicitly upon the following:

1. Degree programs

Objectives

- consistency of the program with the University's mission, and Temerty Medicine's and Department's academic plans
- program requirements and learning outcomes are clear, appropriate, and align with the relevant undergraduate and/or graduate degree-level expectations

Admission requirements

- appropriateness of admission requirements to the learning outcomes established for completion of the program

Curriculum and program delivery

- curriculum reflects the current state of the discipline or area of study and is appropriate for the level of the program
- appropriateness and effectiveness of the program's structure, curriculum, length, and mode(s) of delivery to its learning outcomes and degree-level expectations; clarity with which these have been communicated
- evidence of innovation or creativity in the content and/or delivery of the program relative to other such programs
- opportunities for student learning beyond the classroom
- opportunities for student research experience

Assessment of learning

- appropriateness and effectiveness of the methods used for assessing student achievement of the defined learning outcomes and degree-level expectations, especially in the students' final year of the program

Quality indicators

- assessment of program against international comparators
- quality of applicants and admitted students; enrollment
- student completion rates and time to completion
- quality of the educational experience, teaching, training, and graduate supervision
- implications of any data concerning post-graduation employability (where available)
- availability of student funding
- provision of student support through orientation, advising/mentoring, and student services
- program outreach and promotion

Additional graduate program criteria

- monitoring and management of students' time to completion in relation to the program's defined length and program requirements
- quality and availability of graduate supervision
- faculty commitment to student mentoring
- student quality, including for example grade level for admission, scholarly output, success rates in provincial



- and national scholarships, competitions, awards and commitment to professional and transferable skills
- evidence of a program structure and faculty research that will ensure the intellectual quality of the student experience
- program course requirements are sufficiently met through graduate-level courses

Quality enhancement

- initiatives taken to enhance the quality of the program and the associated learning and teaching environment, including initiatives taken to promote student wellbeing and resiliency in the learning and teaching environment
- extent to which initiatives have been undertaken to enhance the program's accessibility (i.e., for students requiring physical or mental health accommodations) and diversity

2. Other educational programs/activities

- scope, quality, and priorities of any collaborative, undergraduate/postgraduate medical education, and continuing education programs, and leadership and faculty development activities, etc.

3. Faculty/research

- scope, quality, and relevance of faculty research activities
- appropriateness of the level of research activity and funding relative to national and international comparators
- appropriateness of research activities for postdoctoral fellows and undergraduate and graduate students
- diverse faculty complement plan
- appropriateness and effectiveness of the academic unit's use of existing human resources. In making this assessment, reviewers must recognize the institution's autonomy in determining priorities for funding, space, and faculty allocation.

4. Relationships

- strength of the morale of faculty, students, and staff
- initiatives undertaken to enhance a sense of an inclusive community in the Department
- scope and nature of relationships with cognate Departments

- extent to which the Department has developed or sustained fruitful partnerships with other universities and organizations in order to foster research, creative professional activities, and to deliver teaching programs
- scope and nature of the Department's relationship with external government, academic, and professional organizations
- social impact of the Department in terms of outreach – locally, nationally, and internationally

5. Organizational and financial structure

- appropriateness and effectiveness of the Department's organizational and financial structure, and its use of existing human, physical, and financial resources in delivering its programs
- In making this assessment, reviewers must recognize the institution's autonomy in determining priorities for funding, space, and faculty allocation
- appropriateness with which resource allocation, including space and infrastructure support, has been managed
- opportunities for new revenue generation

6. Long-range planning challenges

- clear articulation of a strategic academic plan that is consistent with the University's and Temerty Medicine's academic plans
- appropriateness of
 - » complement plan, including balance of tenure-stream and non-tenure-stream faculty
 - » enrollment strategy
 - » student financial aid
- consistency with Temerty Medicine's commitment to inclusion, equity, and diversity to attain [Excellence Through Equity](#)
- planning for advancement and leadership in approaching alternative sources of revenue, and appropriateness of development/fundraising initiatives
- space and infrastructure considerations
- management, vision, and leadership challenges in the next 5 years

7. International comparators

- assessment of the Department and the programs under review relative to the best in Canada/North America and internationally, including areas of strength and opportunities

Executive summary

Our department is the largest of its kind in Canada and unique in the Temerty Faculty of Medicine. Established in 1997, we are a network of basic science and clinical faculty located across Toronto at 6 fully affiliated hospitals, 8 research institutes, 9 community affiliated hospitals, and the Medical Sciences building with a MaRS node.

We pride ourselves as a department at the interface of research and clinical practice with a focus on education. We are a microcosm of the University as we deliver educational programs in undergraduate Arts and Science, graduate school, unique course-based professional Masters' programs, in medical school, clinical training in all disciplines of lab medicine, as well as for continuing professional development.

The number of graduate students has increased 20% over the last seven years and we currently have 215 in our program this Fall. Our graduate faculty now number 211 which has allowed us to increase the number of graduate students in our program. The LMP undergraduate Pathobiology program increased from 23 acceptances in 2013 to 41 in 2020 following the revamping of its curriculum. Since 2013, over 500 students graduated from our undergraduate program and over 300 from our MSc/PhD programs. Between 2016 and 2020 we trained 155 residents in Pathology, Hematopathology, Forensics, and Neuropathology, 16 clinical chemists, 25 clinical microbiologists and medical microbiologists. We had 140 clinical fellows and graduated 10 physicians from our Royal College of Physicians and Surgeons Areas of Focused Competency programs (Cytopathology and Transfusion Medicine). 217 people have attended our continuing professional development (CPD) events this year so far, nearly double that of last year.

LMP is a research-intensive department. Our total grant funding increased 42% from \$30 million in 2016 to \$42.7 million in 2020, with \$7.4 million and \$11.7 million respectively coming from tri-agency funding. We currently have 12 Canada Research Chairs (CRC) – three awarded this year – and three term Chairs/Professorships, one in neuroscience and the other two in Artificial Intelligence (search ongoing for one of these).

Our scientists and clinician-investigators have been very productive and are contributing to advancing basic knowledge in a number of different areas including cardiovascular, genetics/epigenetics, genomics, proteomics, cancer, development and aging, metabolism and nutrition, neurobiology and neurodegeneration, stem cells and regenerative medicine, artificial intelligence and computational biology, and infectious and inflammatory disease.

We published 10,848 publications over the past five years in over 50 different journals which include high impact journals such as Cell, Cell Stem Cell, Blood, Circulation, ACS Nano, and Nature Communications. Although challenging to compare our unique research portfolio, U of T's output in the areas of biochemistry and molecular biology, microbiology, pathology, and cell biology puts us firmly in the top 10 global institutions for the number of times our publications have been cited and U of T is the leading Canadian institution in these fields.

The LMP clinicians, who account for 61% of our scholarly output, provide up to date expertise in all the disciplines of laboratory medicine and contribute to advancing their specialties through academic activities. They are critical to training the next generation of laboratorians, both postgraduate trainees and clinical fellows.

We have made significant advances in education and research to position LMP faculty as leaders in the field especially as it relates to the changing nature of our professions and development of Artificial Intelligence in healthcare.

We face challenges in funding due to instability in the external funding landscape, coupled with narrowing departmental margins due to Faculty cost-containment strategies and increasing personnel costs. We are also witnessing a decreased profile and exposure to Laboratory Medicine and Pathobiology in medical education which affects our recruitment pools. However, we remain optimistic. The changes we are making to lead the way in our fields, and in our educational programs, put us on a solid path for the future.

That our department continued to thrive during this time reflects the strengths and resiliency of our outstanding faculty, learners, and staff.

During the last four years, we have implemented many changes and new initiatives in LMP to enhance education and research and bring our community together.

These include:

Education

- We have, in consultation with our students and partners, reworked the curricula for both our Undergraduate Specialist Program in Pathology and our MSc/PhD graduate research stream.
- The MHSc in Translational Research program found its home in LMP due to our focus on translation and the team continues to adapt the design and delivery of the curriculum in this innovative and unique program, while we make efforts to stabilize its teaching pool.
- We launched a new MHSc in Laboratory Medicine in the midst of the pandemic: a professional master's program aimed at educating Pathologists' Assistants and Clinical Embryologists. This is the only program of its kind in Canada, created in collaboration with Obstetrics and Gynaecology. Our first students started four months after government approval in September 2020, which is a testament to the commitment of our faculty to address a societal need. To support the clinical embryology program we built a skills/simulation lab with donations from a number of clinics and companies.
- We established a one-month 'Bootcamp' for all first-year anatomical pathology residents to provide a basic introduction to pathology and to support PGY-1 trainees during the transition to a lab-based clinical practice.
- We are currently developing a new program in Computational Medicine and Biology with the Department of Computer Science. Together we have recruited two new faculty to this program and there is an ongoing search for a lead.

Research

- We developed the concept, shepherded it through University governance, and are now the home to the recently established T-CAIREM (Temerty Centre for Artificial Intelligence in Research Education in Medicine). This is a faculty-wide initiative supported by a large donation from the Temerty family. The inaugural Director (Dr. Muhammad Mamdani) and his team is building a remarkable network of opportunities for machine learning research, collaboration, and education as well as a data warehouse infrastructure to facilitate these activities.
- We instigated and spearheaded the internal peer review system in 2019 that now provides internal review services to grant applications across Temerty Medicine.
- Our Quality Council began to conduct research into clinical laboratory practices across the Greater Toronto Area in an effort to enhance patient care and increase harmonization across hospital labs.

Our community

A big focus of life in LMP is our community. We are committed to fostering a dynamic, equitable, inclusive, and professional environment in which all members feel safe, respected, and valued, and empowered to contribute to our core missions of research, clinical service, and education.

To this end we:

- developed a WIDE committee (wellness, inclusion, diversity and equity) composed of representatives from across LMP in 2018 that has worked to bring transparency and equity into our department and to highlight wellness.
- improved our communications by developing our website, launching a monthly newsletter for the community and regular communications from the WIDE committee which kept us connected during the pandemic. Our "Words of Wellness" – tips shared by WIDE members – continue monthly.
- have offered workshops on unconscious bias and allyship and are developing a bank of resources on our website.



- provide support for leadership training which, since it was launched in 2019, has held three competitions and funded a total of 11 faculty (73% female, 27% male). Dr. Cathy Streutker and Patricia Cayetano have developed workshops that help prepare faculty for 3-year reviews or promotion and supported lectures on emotional intelligence (EQ) qualities.
- developed mentoring programs for students, involving our alumni, and for faculty.
- in collaboration with Ike Okafor, Senior Officer, Service Learning and Diversity Outreach, Dr. Paul Hamel helped us extend our outreach to undergraduates from under-represented groups. Dr. Hamel also developed a summer program for these undergraduate students interested in a career in biomedical sciences or medicine to obtain lab research experience, and mentoring, that helps them improve their competitiveness for graduate programs and medical school.

I believe this self-study report provides evidence that LMP has accomplished a lot since the last review and that the department has plans to continue advancing knowledge and enhancing patient care while training the next generation of laboratorians and scientists and those who translate at that interface. However, we know that we still have a lot to accomplish as Winston Churchill said, “Success is not final, failure is not fatal, it is the courage to continue that counts.”

I thank the Executive Committee and all our faculty, staff and learners for their continued contributions to LMP's growth and development, and for their support of me as Chair – all of our achievements are due to a collective energy, dedication, and passion for what we do.

2013 External Review: key findings and progress

The last major external review of the department was in September 2013, during the term of Dr. Richard Hegele. This review was conducted by Dr. Victor A. Tron (Head of Pathology and Molecular Medicine, Queens University, Kingston, Ontario), Dr. Subrata Chakrabarti (Chair of Pathology, Western University, London, Ontario), and Dr. Jonathan Braun (Chair of Pathology and Laboratory Medicine, University of California, Los Angeles, USA).

The following is a synopsis of the major comments and recommendations from that review (in bold), each followed by a summary of our progress.

Undergraduate studies: we endorse an initiative to increase enrollment

The undergraduate program has undergone a complete re-organization since the last review. We have appointed two new Co-Coordinator of the Specialist Program in Pathobiology who are also Co-Associate Chairs, Undergraduate Life Science Education. They have placed extra emphasis on recruitment outreach. The department has been well represented at several U of T campus recruitment events, such as U of T Fall Campus days, A & S PoST selection week, and U of T Medical Student Society. Furthermore, they have a recruitment information session for students invited into the program. These actions have allowed the program to attract and convince top students to accept the offer into our program. All these efforts combined have resulted in increased number of students accepted into the program from 23 students in 2013 to 41 in 2020. Despite the enrolment increases, the quality of the students has been maintained, as can be observed by the minimum high school average and percent average in the first year.

Graduate studies: the program will further benefit if all faculty members are regularly made aware of the various processes and procedures and there is engagement of more faculty members in the management of the program. As international students have to pay a significant differential fee, the requirement for concordantly increased stipend support by supervisors limits the number of faculty who are able to take international students.

The graduate program has undergone a complete re-organization since the last review. We have appointed two new Graduate Co-Coordinator and re-organized the administrative office. One of the Coordinators is a Vice Chair, Education Life Sciences and serves not only on the Executive committee but also as the bridge to the undergraduate program.

The LMP website has been completely revamped and includes all relevant learner and faculty information regarding graduate studies in accessible formats.

Revamping the graduate and undergraduate curricula has allowed for more involvement of our faculty. Where needed we have formed committees to promote faculty input.

The fee differential between international and domestic graduate students was unfair but not under the control of LMP. Fortunately, the University has eliminated this fee differential for international students. However, they only fully support the department for a limited number of positions so LMP has to absorb the funding loss. Nevertheless, this fee alteration has increased the number of international students accepted into research stream graduate studies – almost 50% of PhD students accepted for Fall 2021 are international.

Medical school: the department may consider increasing elective and selective offering and may also combine such offering with other departments (e.g. surgery or gastroenterology).

Having sufficient time in the medical school curriculum to teach medical students lab medicine principles is a problem common to many departments like ours. We have not been successful obtaining more time in the curriculum. Instead, we took other approaches, e.g. co-curricular and selectives/electives.

We appointed a lead for undergraduate medicine and created opportunities to increase exposure to the lab medicine discipline, e.g. developing a pathology special interest group, shadowing a pathologist, and selectives/electives were all made available. For the past two years our trainees have led an interesting pathology case of the month. We are continuing to explore other opportunities to increase medical student knowledge about pathobiology and the laboratory medicine disciplines.

Continuing education: Continuing education program may further be expanded with use of new technology.

We appointed a new CPD lead who revamped the CPD program. She has developed a robust program that pivoted to virtual with the onset of COVID-19 and numbers of CPD participants have nearly doubled since this change in format. She is now forming a committee that will have members from all the other lab disciplines who will have as their mandate to expand CPD presentations.

Faculty: the department may consider making a plan to support specific researchers if they lose their grants. Furthermore, the departmental translational research agenda can be moved forward with increased interaction with U of T based researchers, Hospital based researchers and pathologists.

To date, LMP faculty members have been, by and large, successful in competing for grants so that the department has not needed to provide contingency funds which is a testament to the excellence of our researchers.

The reviewers' comments on LMP establishing "rainy day funds" to address research funding pressures has been addressed by focusing on supporting LMP graduate students. The occasional shortfalls in graduate stipend support that have occurred have been covered by funding from the SGS Doctoral Completion Award Program, and the Department's U of T Fellowship allocation. Approval for this funding allocation is decided by both graduate Co-Coordinators.

Supporting research shortfalls have not been possible to date, given the limited funding available to departments for this activity. We are actively looking for donors to support research in our department.

Clinical faculty: one potential unifying role that LMP could take is to work with hospitals to develop alternate payment plans for pathology medical groups. This direction could emphasize the importance of all the required elements of an academic practice and give a sense of ownership/professionalism to the faculty.

This has been a work in progress. More recently the Chiefs, as a group, have come together to develop a common approach to a workload measure. We have automated the annotation of work which will simplify this process and are planning to implement it this fall. Having a common workload measure amongst the hospitals is the first step in supporting an alternate payment plan.



LMP organization: due to the complexity of the department and a complex relationship with large hospitals and research institutes, there may be a challenge in resource allocation to perform academic mandates of LMP allocation to perform academic mandates of LMP.

We have strong relationships with our hospital departments who support LMP academic activities. Additionally, we have been able to provide funding to partially support these activities and promote the department's many academic endeavors.

Infrastructure: however, to achieve its strategic agenda, expanded space and research infrastructure may be an issue.

Space and infrastructure is always an issue but we have been fortunate as Temerty Medicine has been very helpful in addressing these. Since the last review two of our labs have moved to MaRS and four of the 6th floor MSB labs were newly renovated and benching updated. Recently they have supported renovations to improve the efficiency of the usage of our space.

Hospital-department interactions: there are some challenges regarding the interactions with hospitals. LMP should try to take steps towards developing some unified approach to emphasize to faculty the importance of academic activities.

There is no question that there are challenges in ensuring that such a diverse group of individuals feel connected to LMP. This is a major goal identified in our new strategic plan. We have tried several ways to accomplish this, for example the weekly LMP Seminar Series, is our "city-wide academic rounds" and open to all. The series includes speakers from a variety of areas, basic science, clinical, and translational research on topics of interest to the LMP community or issues pertinent to global health and justice. Students are also allotted two slots for which they can select the speakers. We have also used this time to highlight the research of our recently promoted Professors. In the 2021–22 series we will also include speakers on EDI.

On a more "micro" scale, there are various specialty-specific city-wide rounds (e.g. neuropathology, clinical biochemistry). Continuous professional development initiatives around "communities of practice" have been initiated. Increased use of videoconferencing and digitization has expanded the "LMP presence" in such activities. This will continue to improve as it is a focus of our new Strategic plan.

Branding: the department may also look at the branding. Although this may be a difficult and sensitive issue, aligning all research (regardless of the specific sites, where they were performed) with LMP – U of T may have an added advantage to raise departmental, hospital and university profiles internationally.

As noted in the previous Chair's response to the reviewers, the hospitals now allow inclusion of LMP and University affiliations in all publications by faculty members. This branding has increased the profile of the University and department.

Challenges

LMP faces many challenges in the next five years, not dissimilar in many ways to other biomedical departments.

Examples of some of these are as follows:

- Obtaining more time in the medical school program to teach pathobiology, educate students on the principles of test utilization, and to provide exposure to the lab disciplines so they appreciate that they are critical specialties in the care of the patient
- Toronto cost of living is impacting recruitment/retention of individuals to be part of our department
- Salary support for clinician-scientists in lab medicine disciplines to ensure research
- Finding funding to provide bridging funds for scientists to be able to maintain their labs during these constrained times and to purchase new lab equipment
- Proper staffing of clinical departments to allow sufficient time for academic activities
- Fundraising to support LMP initiatives

Self-study participation

This report is the output of a large team across LMP. Many people have contributed to the gathering of data and opinions, in addition to those listed below for their specific contributions.

Co-ordination and editing of report	
Dr. Rita Kandel	Department Chair
Nelson Cabral	Manager, Business and Administration
Jenni Bozec	Communications and Outreach Officer
Administration and collection of data	
Patricia Cayetano	Senior Administrator, Human Resources
Xilonem Lopez	Administrative and Appointments Assistant
Ravinder Dhillon	Finance and Grants Administrator
Louella D'Cunha	Undergraduate Life Sciences Program Administrator
Brandon Wells	Graduate and Life Sciences Education Officer
Ian Marquez	Graduate Program Administrator
Jana Neiman-Zenevich	Translational Research Program Officer
Julie Wei	Translational Research Program Administrator
Paula Nixon	Postgraduate Education Officer
Sue Balaga	Postgraduate Assistant
Marianne Freire-Gormaly	Departmental Assistant
Drafting of specific reports	
Dr. Jeremy Mogridge, Dr. Michael Ohh	Graduate Research Stream Programs
Dr. Jeffrey Lee, Dr. Karim Mekhail	Undergraduate A&S Specialist Program in Pathobiology
Dr. Joseph Ferenbok, Dr. Harry Elsholtz	MHSc in Translational Research
Dr. Avrum Gotlieb, Dr. Harry Elsholtz	MHSc in Laboratory Medicine
Dr. Susan Done	Residency Programs: Anatomical Pathology
Dr. Andrew Gao	Residency Programs: Neuropathology
Dr. David Barth, Paula Nixon	Residency Programs: Hematological Pathology



Dr. Jayantha Herath	Residency Programs: Forensic Pathology
Dr. Tony Mazzulli	Residency Programs: Medical Microbiology
Dr. Vathany Kulasingam, Dr. Paul Yip	Postdoctoral Diploma programs: Clinical Biochemistry
Dr. Tony Mazzulli	Postdoctoral Diploma programs: Clinical Microbiology
Dr. Wendy Lau	AFC Programs: Transfusion Medicine
Dr. Zeina Ghorab, Dr. Joerg Schwock	AFC Programs: Cytopathology
Dr. David Hwang	Fellowship Programs
Dr. Corwyn Rowsell	Undergraduate Medical School Education
Dr. Anna Plotkin	Continuing Professional Education
Dr. Stephen Girardin, Dr. Myron Cybulsky, Shawn Healy, Strategic Research Data Coordinator, Temerty Medicine	Research
Dr. Khosrow Adeli	Quality Council
Dr. Michael Pollanen	Global Health
Carmen Sebert, Associate Director, Strategic Initiatives, Temerty Medicine	Advancement and Alumni Relations
Debb Yorke, Dr. Isabelle Aubert	Wellness, Inclusion, Diversity & Equity (WIDE)
Patricia Cayetano, Dr. Cathy Streutker, Dr. Sharon Nofech-Mozes	Our faculty
Collection of surveys and opinions	
Patricia Cayetano, Dr. Cathy Streutker	Faculty opinion survey
Laboratory Medicine and Pathobiology Students' Union (LMPSU)	Undergraduate student voices
Confederation of Laboratory Medicine and Pathobiology Students (CLAMPS)	Graduate student voices
Ariel Gershon (trainee)	Resident feedback: Anatomical Pathology
Maliha Khara (trainee)	Resident feedback: Forensic Pathology
Sakara Hutspardol (trainee)	Resident feedback: Hematological Pathology
Jennifer Tat (trainee), Shawn Clark (trainee)	Postdoctoral Diploma/resident program feedback: Medical and Clinical Microbiology
Jessica Miller (trainee), Ashley Di Meo (trainee)	Postdoctoral Diploma program feedback: Clinical Chemistry

Future directions

We are in the final stages of determining our strategic plan 2021–2026. Our planning process has involved a wide variety of ways for our faculty, learners and staff to lend their voices and be involved in the process, generating a plan that truly reflects the department as a whole.

Our plan considers the seismic changes of precision medicine and “omics”, artificial intelligence, advanced imaging, and global effect of climate change on clinical diagnostics, research and education. It acknowledges that the future is difficult to predict so instead our plan focusses on how to develop resilient faculty, learners and staff who are nimble and able to pivot quickly as demanded by a future in flux.

Through the planning process, we have acknowledged that LMP is already a leader in many significant areas, but we are not widely communicating or promoting our work. This is limiting connection and collaboration, with faculty and learners eager to know more about each other and to find new opportunities to connect. With the recruitment in the last year of a Communications and Outreach Officer, communicating what we do will be a large focus for the next few years.

To meet these considerations, we have articulated an approach to strategic change with four types of activities:

- **Promote:** what we are already doing...
- **Connect:** for new possibilities...
- **Amplify:** our foundational strengths...
- **Invest:** in targeted, focused areas that will have impact

With this approach as guidance, we co-created a strategic framework with five priorities. We will foster an **Inclusive, Energized Community, deepening Dynamic Collaboration and Technological Dexterity** against the backdrop of ever-stronger **Consequential Research and Agile Education**.

Strategic Framework: From the Lab to the World

Our overarching mission: *“transform the understanding and diagnosis of disease pathogenesis, through the integration of innovative research, education and clinical practice.”*

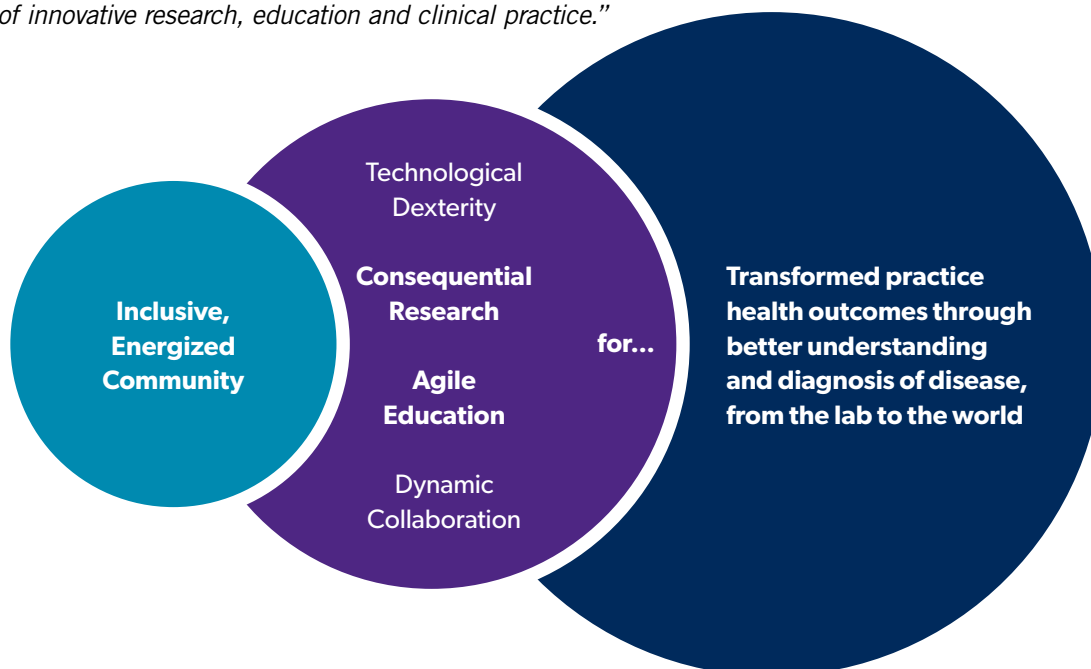

Over the next five years, we will work toward a vision of “transformed practice and health outcomes through better understanding and diagnosis of disease, from the lab to the world.”



Each priority will have its own adaptable action plan. In addition, we will identify and drive two or three “hallmark initiatives,” opportunities to engage diverse faculty, learners, staff and other collaborators to collectively contribute to projects that will advance the vision across multiple priorities.

1. **Amplify our public voice:** Use the post-COVID heightened awareness of science to raise understanding in the world of the purpose, impact and value of the laboratory medicine disciplines and research, now and into the future.
2. **Spark catalytic collaborations:** Create small community projects around questions that will have a meaningful impact in the local or global community, encouraging multi-disciplinary teams to spark new collaborations of students, staff, faculty and alumni across the department.
3. **Work towards building relationships with international networks and partners** to advance knowledge and the practice of lab medicine and improve health outcomes in Canada and globally.

Five strategic priorities

1. Inclusive, energized community

Goal: Co-create a truly equitable, inclusive learning and working environment for all learners, faculty, staff, and partners.

Objectives:

- a) Deepen our work as a **truly inclusive, equitable, accessible and diverse learning and working environment** for learners, staff, and faculty, through: creating spaces, visual cues and tools to foster connection and belonging; creating safe, brave spaces to openly discuss issues of racism and inequity; supporting international students as well as learners and faculty from diverse communities.
- b) Strengthen **outreach and recruitment** of diverse students, diagnostic laboratorians, and scientists from wider communities, particularly those from under-represented groups (esp. Black, Indigenous and People of Colour). Develop specific recruitment strategies, with outreach to high schools and undergraduates.
- c) Establish **wellness and wellbeing** as a fundamental aspect of our community, developing sustainable structures and processes that enable everyone to work at their best, ensuring access to wellness resources for everyone, and faculty role modeling wellness to their trainees and colleagues.

2. Dynamic collaboration

Goal: Build our capacity as “the” prominent site for the collaborations that make the most of new technologies, fuse ideas in novel and meaningful ways, and rapidly apply new knowledge to practice for improved research and health outcomes and effective practice.

Objectives:

- a) **Enhance connections between basic science and clinicians**, across programs, disciplines and across the university, to address clinical needs and create research strategies to address them. Develop a platform to enable faculty and learners to find people who are interested in the same topics, approaches and/or opportunities.
- b) **Create the structures that enable and incentivize collaborations** – e.g., cross-disciplinary catalyst grants, co-supervision, standardization of practices, joint courses and cross-pollination across disciplines.
- c) Identify **cross-university opportunities for natural partnerships** to fill a clinical and knowledge gap, e.g., clinical embryology, computational medicine & biology
- d) **Strengthen our connection to international collaborations and networks** for a greater global impact.

3. Technological dexterity

Goal: Fortify our foundational expertise in emerging fields and technology to enable diverse opportunities for leadership, collaboration and synergy.

Objectives:

- a) **Deepen our existing strength in precision medicine** by expanding integration of advanced imaging, omics and big data.
- b) **Create departmental areas of focus in emerging technology**, such as bringing “omics” into a single assay, integrating AI into clinical contexts, refining AI algorithms from an EDI lens, investing in microbiology (“get ahead of the next pandemic”) and advancing point of care diagnostics.
- c) **Seize opportunities to advance clinical diagnostics, practice and therapeutics and research, using emerging technologies** (e.g., AI and digital pathology, and advanced imaging).

4. Consequential research

Goal: Solidify our leadership in the full spectrum of science, from curiosity research to commercialized innovation, to transform practice and health outcomes.

Objectives:

- a) **Strengthen access to shared resources** such as core facilities that enable us to optimize resources, build strong research programs at all stages of our careers, and create opportunities for emergent collaboration.
- b) **Develop frameworks and infrastructure to share data of all kinds** (e.g. omics, diagnostic, clinical), including access to anonymized data from multiple sites.
- c) **Strengthen basic science and curiosity research to continue** expanding our connection to emerging ideas.
- d) **Strengthen faculty development and promote an integrated community of researchers from across the spectrum of basic scientists to clinician scientists**, to support and mentor early career researchers, create opportunities for shared learning, and build capacity for continual development across the career lifespan.
- e) In collaboration with Temerty Medicine, **advocate and work to simplify “red tape”** around research between hospital sites and the universities.
- f) Accelerate **recruitment of faculty** who can lead interdisciplinary research/teaching/innovation and who are agile and positioned to enhance our research and education strategies, especially in key areas (e.g. virology).

5. Agile education

Goal: Create personalized, flexible, equitable and integrative education that reflects the evolution of our field and supports learners to develop as scientists and clinicians who will be lifelong learners and leaders.

Objectives:

- a) **Continue to evolve our curriculum** to incorporate the rapidly changing fields, creating connections to the edges of science, develop new opportunities in commercialization, include relevant spheres like bioethics and regulation, grow the understanding of the significance of translational research, and provide a deep understanding of evolving practice. Embed a core stream of “emerging essentials” that everyone who studies at LMP will develop basic literacy in, regardless of their discipline (e.g., genomics, AI).
- b) **Build culture of self-guided learning for students**, supporting capacity for life-long development and personalized pathways and knowledge goals.
- c) **Embed equity, diversity and inclusion into the curriculum**, developing capacity to ensure research, clinical interventions and learning environments are truly inclusive and accessible, that sciences and technologies address structural inequities, and that our work drives health equity.
- d) **Develop innovative teaching models** for virtual and in-person learning.
- e) **Develop individualized pathways** that enable accessible, cross-program collaboration and allow students to engage with topics that interest them outside the boundaries of their programs (“personalized learning”); ensure every student has a full understanding of the options available to them and how to shape their learning around their passions.
- f) **Strengthen education scholarship** around our evolving approach to integrative learning and to continually learning and improving.
- g) **Work to embed the basics of LMP knowledge** into the broader medical/health science education across the Faculty to strengthen both the awareness of lab diagnostics on health and the capacity for collaboration.



Life Sciences Education

Research stream graduate programs

We offer research stream MSc and PhD degrees. Students in these programs join laboratories on campus or at university-affiliated hospitals and research institutes.

Major areas of investigation being carried out by our faculty and students include:

- Brain and Neuroscience
- Cancer, Development and Aging
- Cardiovascular, Physiology and Metabolism
- Infectious Diseases, Inflammation and Immunology
- Molecular and Cell Biology and Regenerative Medicine
- Computational Medicine and Biology

We provide opportunities for our students to participate in basic, translational and clinical research, as well as taking graduate courses in support of their training.



MSc at a glance

Perform coursework and complete a research-based thesis.

Take a foundational course to develop sound research practices and seminar courses to strengthen scientific communication skills.

Present their research in an oral presentation as part of a seminar course and through a poster presentation at the [LMP Research Conference](#).

Establish a thesis advisory committee consisting of the student's supervisor and two members of the University's graduate faculty to supervise and advise on their research

Defend their thesis during an oral examination which is deemed successful when student has produced novel data, demonstrates an understanding of how their work contributes to their research field, and of the limitations of their findings.

PhD at a glance

Complete a research-based thesis and take advanced graduate courses in selected areas of medical research to learn from experts in a given field and to further develop critical thinking skills.

Present their work in a seminar course and at the [LMP Research Conference](#).

Establish a thesis advisory committee consisting of the student's supervisor and two members of the University's graduate faculty.

Defend their thesis in front of an examination committee consisting of their advisory committee and at least one graduate faculty member who is not associated with the work, an expert in the field who is not associated with the work or with the University of Toronto will appraise the thesis. The thesis must have at least two distinct data chapters that either have been, or very likely will be, published in peer-reviewed journals that are recognized by experts in the field. To successfully defend a PhD thesis, the student must demonstrate a level of thinking that is consistent with that of an independent scientist.

The MD/PhD Program

Since 2015, we have enrolled 12 LMP PhD students who applied to our department from U of T's MD/PhD program. Students in this program finish the first one–two years of medical school and then complete a PhD before returning to medical school. They must complete all requirements for the PhD degree outlined in this section.

The Clinician Investigator Program

Residents in the clinical programs have the opportunity to apply to do a PhD during clinical training in a program organized by the PGME office. See Residency Training Programs, [page 104](#) for more information.

Learning outcomes

The MSc Program

Designed to train students to develop research skills and scientific rigour, those who complete the program will be able to design and carry out experiments that generate novel data. This will require students to have a substantial knowledge of their field, be able to identify knowledge gaps and to generate novel hypotheses.

Students will be able to:

- design experiments that are feasible and that yield definitive answers to their question
- make sound conclusions from their experimental results
- identify limitations in their methods and findings
- explain their work to audiences that have various levels of expertise
- write a thesis, and if possible, one article.

The PhD Program

Designed to train students to become independent research scientists. Those who complete the program will be able to design and direct research projects. Students will attain expertise in their field of interest and have considerable knowledge of work in the related fields.

2 Research stream graduate programs

Students will be able to:

- design experiments
- interpret results
- understand experimental limitations
- identify alternative and complementary approaches to strengthen conclusions
- write thesis and primary research articles suitable for publication in respected, peer-reviewed journals
- become proficient at scientific communication.

Admission requirements

We admit students based on the [General Regulations of the School of Graduate Studies](#). Applicants must also satisfy our departmental admission requirements stated below.

Our departmental admissions committee selects successful students based on their academic excellence. We finalize admission when a graduate faculty member agrees to supervise the student's research and guarantees a full stipend for the student.

Admission requirements: MSc

Applicants must have completed, or be about to complete, one of the following:

- Pathobiology Specialist program (see Undergraduate A & S Specialist Program in Pathobiology, [page 46](#)).
- an appropriate bachelor's degree in life sciences from a recognized university.
- professional degree (e.g., MD, DDS, DVM, or equivalent).

Applicants must also have:

- A minimum A– average over the final two years of undergraduate study.
- Two strong letters of recommendation from faculty members familiar with their academic work using departmental appraisal forms.
- Detailed curriculum vitae (CV).
- Statement of intent (approximately 250 words).
- Research experience evidenced by publications, abstracts, or presentations is an asset.

Admission requirements: PhD

We normally require research experience evidenced by peer-reviewed publications, abstracts, or presentations.

Applicants must also have:

- Three strong letters of recommendation from faculty members familiar with their academic work using departmental appraisal forms. Normally, one of the referees should be the applicant's research supervisor.
- A detailed curriculum vitae (CV).
- Statement of intent (approximately 250 words).

A limited number of students may enter the MD/PhD program subject to admission into both the departmental PhD program and the MD program.

Admissions requirements: PhD (Direct Entry)

Direct entry is available for highly qualified BSc graduates who have completed the Pathobiology Specialist program or an appropriate undergraduate program in the life sciences from a recognized university with a minimum A average in the final two years and relevant research experience.

The application requirements are the same as stated in the PhD program.

MSc to PhD transfer requirements

Excellent students with high academic standing (normally a minimum A– average on MSc courses) who have clearly demonstrated the ability to do research at the doctoral level may be considered for transfer to the PhD program if recommended by their advisory committee.

Transfer applicants must:

- Be enrolled in the MSc program in Laboratory Medicine and Pathobiology.
- Successfully complete a reclassification transfer exam within 24 months of starting the MSc Program.
- Successfully complete 'LMP 1001H: Student Seminar' and 'LMP 1005H Fundamentals of Research Practice' at the master's level.
- Be enrolled in 'LMP 1002H Student Seminar II' at the time of writing the reclassification exam.



Graduate student recruitment



Applications received by February 1 are eligible for entrance scholarships

Students must secure a supervisor before they can be fully admitted to the program (a process referred to as “matching”).

We facilitate matching by directing conditionally accepted students to our searchable online directory of faculty members. This provides descriptions of faculty members’ research programs and indicates whether a faculty member is interested in hiring an MSc student and/or a PhD student. We do not offer a rotation program for new students as the wide diversity of research programs makes this impractical.

Faculty members can access student applications through a secure online Sharepoint site and we provide a list of conditionally accepted students with self-declared research interests to help faculty find suitable applicants.

Both applicants and faculty can initiate interviews.

Program requirements

Students in all our programs must be present at their study location (campus/hospital/research institute) and participate for the duration of their registration in the program. During the COVID-19 pandemic, the manner of delivery of courses, co-curricular opportunities, programs, and services were subject to change, in accordance with university policies and broader public health guidelines.

Program requirements for MSc

Coursework

Students must complete 1.5 full-course equivalent (FCE) which includes:

- LMP 1005H Fundamentals of Research Practice (0.5 FCE)
- LMP 1001H Student Seminar I (0.5 FCE; Credit/No Credit) and LMP 1002H Student Seminar II (0.5 FCE; Credit/No Credit).

Research

- The student must complete a thesis (RST 9999Y) under the direction of their supervisor, assisted by the advisory committee.
- The research content of the MSc thesis is expected to generate the equivalent of one paper published in a peer-reviewed scientific journal.

Program requirements for PhD

Coursework

Students must complete 1.0 full-course equivalent (FCE):

- LMP 1003H Student Seminar III (0.5 FCE; Credit/No Credit)
- an additional 0.5 elective FCE.

2 Research stream graduate programs

Research

- The student must complete a PhD thesis (RST 9999Y) under the direction of their supervisor, assisted by the advisory committee.
- The student's PhD thesis must demonstrate a substantial contribution to laboratory medicine and pathobiology, involving a systematic investigation of disease-related hypotheses. Emphasis is on the quality of the science and its presentation.
- We normally expect the PhD thesis to yield the equivalent of three publications in refereed scientific journals.

Program requirements for PhD (transfer and Direct Entry)

Coursework

Students must complete 2.5 full-course equivalents (FCEs):

- LMP 1005H Fundamentals of Research Practice (0.5 FCE; Credit/No Credit)
- LMP 1001H Student Seminar I (0.5 FCE; Credit/No Credit)
- LMP 1002H Student Seminar II (0.5 FCE; Credit/No Credit)
- LMP 1003H Student Seminar III (0.5 FCE; Credit/No Credit)
- an additional 0.5 elective FCE.

Research

The student must complete a PhD thesis (RST 9999Y) under the direction of their supervisor, assisted by the advisory committee as per the PhD requirements.

All students in the PhD program normally defend their thesis before a departmental committee, and subsequently before a committee approved by the School of Graduate Studies. PhD candidates may request, with the recommendation of their advisory committee, a waiver of the departmental defence, subject to approval by the Graduate Coordinator.

Curriculum design

The graduate curriculum aligns with the department's plan to address the challenges and opportunities associated with the rapidly changing fields and technologies in laboratory medicine and pathobiology by providing a flexible and student-focused graduate program that meets the programs' stated learning outcomes.

Our graduate students spend most of their time devoted to original research. This research culminates in the production of a written thesis that the student defends at an oral examination. Typically, an MSc thesis contains one data chapter, and a PhD thesis contains two to three data chapters.

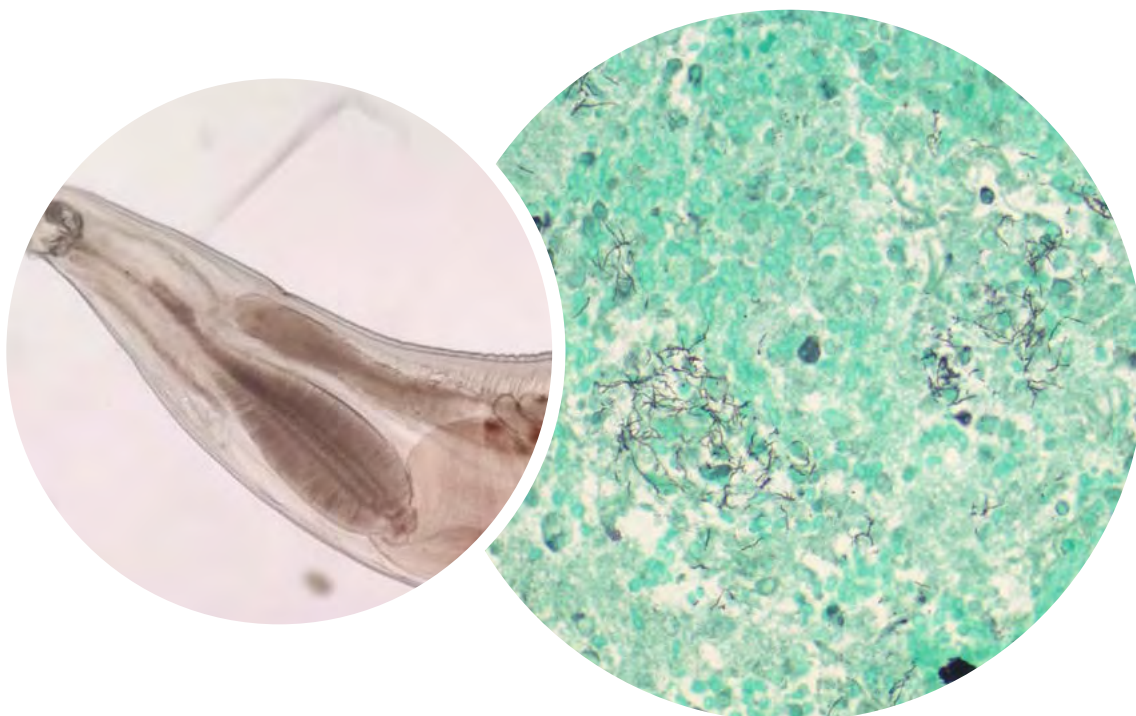



Core curriculum elements

Mandatory for MSc and Direct Entry PhD

Learning the fundamentals

Course: [Fundamentals of Research Practice](#); (0.5 FCE; credit/no credit)

Lectures cover essentials such as good laboratory practice, strengthening oral and written communication skills, statistics and ethics.

Students are assigned primary research articles to develop critical thinking skills.

Developing questioning, discussion and presentation skills

Course: [LMP1001H and LMP1002H](#) (0.5 FCE; credit/no credit)

In the first year of their program, students attend seminars and participate in questioning and discussion sessions (LMP1001H).

In the second year of their program, students attend seminars and deliver a seminar based on their research (LMP1002H).

Mandatory for Regular Entry and Direct Entry PhD

Developing questioning, discussion and presentation skills

Course: [LMP1003H](#) (0.5 FCE; credit/no credit)

A two-year student seminar series. In the first year of the course, students attend seminars and participate in questioning and discussion.

In the second year of the course, students attend seminars and deliver an oral presentation of their research.

Electives to explore interests

Courses: [0.25 and 0.5 credit](#)

PhD students are required to take 0.5 FCE of electives (one 0.5 FCE elective or two 0.25 FCE electives).

We offer a range of elective courses and students may take elective courses offered by other departments with the permission of the graduate coordinators.

The LMP Research Conference

All students attend the annual student-led and run [LMP Research Conference](#).

The research conference showcases our students' research in poster and oral presentation sessions. MSc students submit an abstract in the second year of their program that will either be selected for a poster presentation or an oral presentation. PhD students submit an abstract in the second and fourth years of the program. There are also faculty oral presentations and a keynote speaker, who is often from outside the department.

2 Research stream graduate programs

In 2019, we merged the LMP postgraduate medical trainees' Research Day with the LMP Graduate Research Conference (GRC) to form the combined LMP Research Conference (LMPRC). We also had the conference accredited by the Royal College of Physicians and Surgeons to encourage participation by our clinical faculty.

In 2021, we added our MSc students from the Translational Research Program (TRP) to our conference. Consequently, our LMP Research Conference has become our department's flagship event, led and run by an organizing committee of our graduate students and medical residents, supported by administrative staff.

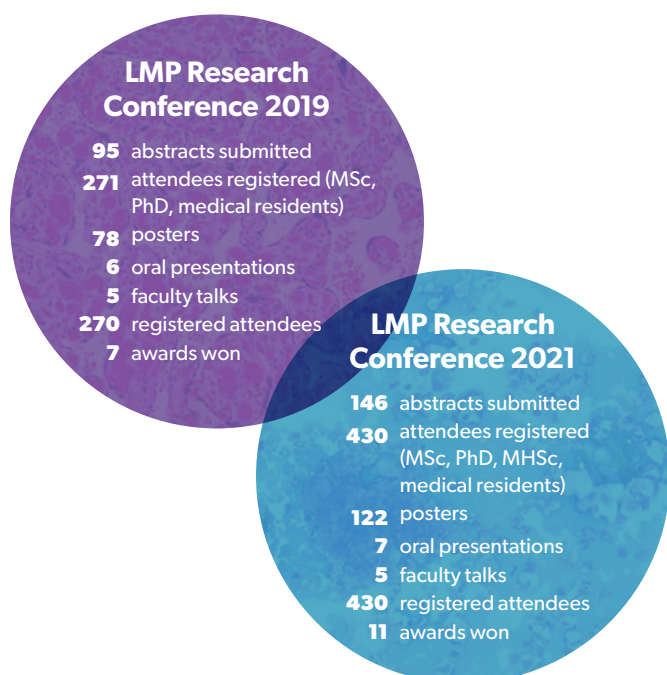

Read more at [LMP Research Day: a virtual success](#)

Assessment of learning

Graduate courses

We use a variety of mechanisms to assess student learning including tests, oral presentations, and assignments. Participation is often used as a contributing factor to the final grade.

'LMP1005 Foundations of Research Practice' and 'LMP1001/1002/1003 Student Seminar Series' are credit/no credit courses.

Assessment of elective courses is through letter grades.

Thesis Advisory Committee meetings

All MSc and PhD graduate students are supervised by a Thesis Advisory Committee (TAC).

The composition of the committee includes the supervisor(s) and two graduate faculty members from the University, one of whom will serve as the Committee Chair. An additional committee member may be added as required to provide expertise for the thesis project.

The first committee meeting takes place within 6–9 months of registration in the program with subsequent meetings scheduled every 10–12 months.

The student submits a progress report one week prior to the meeting which includes an introduction, rationale and aims, results, proposed experiments, and references and must be a maximum of three single-spaced pages plus two pages of figures.

At the meeting, the student gives a 30-minute oral presentation.

The committee provides guidance on the student's research and acts on behalf of the department in ensuring that the student maintains research standards and that the student's progress meets departmental expectations. The committee writes a report on the student's scientific knowledge, experimental skills, industriousness, writing skills, oral presentation skills, and overall progress.

MSc to PhD Transfer Examination

An MSc student who has clearly demonstrated the ability to do research at the doctoral level may, with the recommendation of the thesis advisory committee, request to transfer to the PhD program. Transfer to the PhD program is based on performance at an assessment examination, which is normally held 18–22 months after the start of their MSc.

The examination committee consists of a member of the LMP graduate faculty who chairs the examining committee and may participate in questioning, the thesis advisory committee, and two other graduate faculty members, one of whom is a member of another graduate unit.

The student prepares a research proposal that describes their preliminary data and research plan. At the examination, the student gives an oral presentation



summarizing the report. The examination committee questions the student to assess general knowledge, understanding of experimental techniques, and critical thinking. The committee votes on whether to recommend acceptance into the PhD program based on the quality of the written report and performance at the examination. The vote must be unanimous in order for the student to pass the examination.

MSc Thesis Defense

MSc candidates produce a written thesis based on their original research that they defend in front of an examination committee.

The MSc examination committee is composed of the thesis advisory committee and a graduate faculty member from LMP who serves as chair.

The candidate provides a 20-minute oral presentation that summarizes the thesis work. Following the oral presentation, the candidate will be questioned on the contents of the thesis and on related scientific knowledge.

The candidate is expected to:

- demonstrate expertise in their research field and to understand the significance of their results within their field.
- appreciate the strengths and limitations of their results and be able to draw appropriate conclusions.
- be able to propose additional experiments that will support and extend their findings.

Following the period of questioning, the committee votes on the acceptability of the thesis and oral defence. The candidate fails if there is more than one negative vote or abstention.

PhD Final Oral Examination (FOE)

PhD candidates produce a written thesis that is first reviewed by the thesis advisory committee. Once the thesis is approved, it is distributed to at least one graduate faculty member external to the thesis advisory committee and to an External Appraiser from outside the university who has been approved by the School of Graduate Studies (SGS). The External Appraiser provides a written assessment of the thesis to the candidate and to the members of the examination committee at least two weeks before the oral examination.

At the FOE, the candidate summarizes the major findings of the thesis in an oral presentation, followed by a question period in which the committee assesses the thesis and the candidate's mastery of the subject. The committee then votes and the candidate fails the FOE if more than one negative vote or abstention is recorded.

The FOE committee composition (4–6 members)

- Supervisor
- Internal reviewers
- Internal and External Appraisers
- Chair (appointed by the School of Graduate Studies)

At least two members must not have had any part in the design or execution of the thesis research.

Co-curricular activities

The Confederation of Laboratory Medicine and Pathobiology Students (CLAMPS)

CLAMPS is our annually elected graduate student council. They enhance the scientific program, support wellness, represent the best interests of our students, offer support and guidance, and act as the voice for its members within the School of Graduate Studies and the University of Toronto.

CLAMPS are a highly active group who run and facilitate many initiatives in the department, such as the recently launched peer-to-peer mentoring program for graduate students, a high school outreach program, and peer coaching to help improve student's presentation skills.

The group also leads the organizing committee for the LMP Research Conference and Product Show (see [page 33](#)).

2 Research stream graduate programs

They run a busy social calendar for students, which has continued virtually throughout the pandemic, from yoga to origami, and study groups.

They represent the student body through town hall events, surveys, and sitting on various departmental committees. Working in partnership with the Graduate Office, they are involved in most of our events and initiatives and work continually to improve student services and the student experience in LMP. Representatives meet regularly with the Graduate Co-ordinators, Manager, Business and Administration, and Department Chair.



Quality indicators

Graduate enrollment

The number of MSc students enrolled in the department has increased steadily over the past seven years, whereas the number of PhD students has remained relatively constant.

This trend may reflect the recent uncertainty of supervisors in securing the long-term funding required to support PhD students.



Students enrolled on the program (includes part-time and full-time)

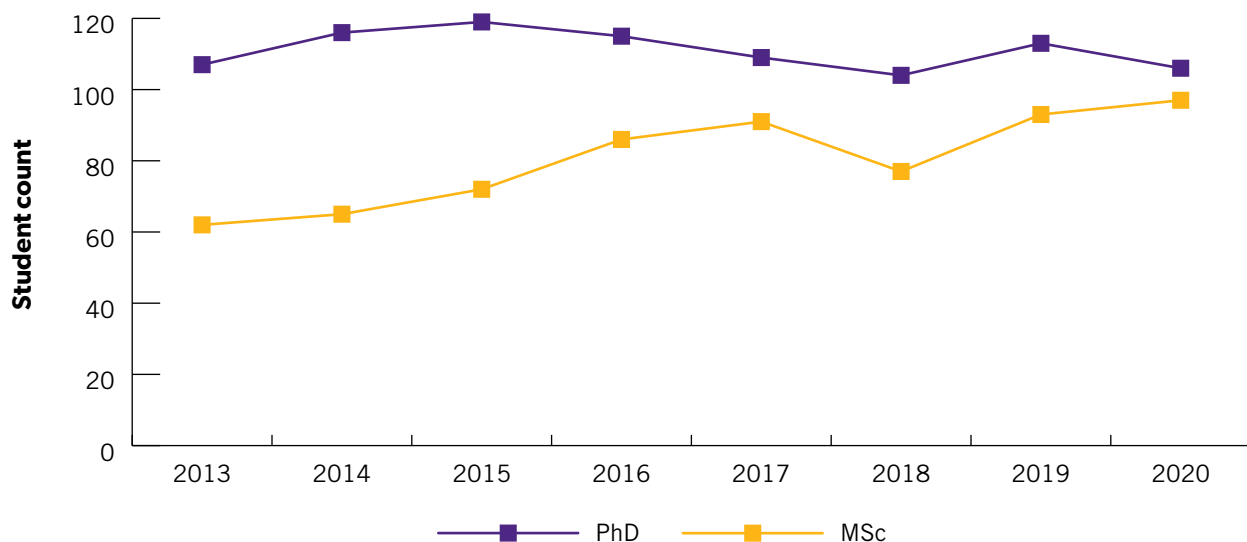



Applications and registrations

The number of applications and enrollments in our program has increased over the past seven years, as well as the number of offers we make.

We changed our admissions policy in 2019–2020, which was reflected in an increase of offers. Previously, we made offers to the top ~35–45% of applicants to the MSc program and to the top ~20–55% of applicants to the PhD

program based on their written applications (CV, grades, letters of reference).

In 2019–2020, we decided to make a higher number of offers that were conditional on the applicant securing a supervisor. We felt that written applications were not enough to identify top candidates and that the admissions committee would not be able to predict the needs of such a diverse faculty. We therefore increased our faculty's involvement in the admissions process.

Applications, Offers, Registrations (MSc)

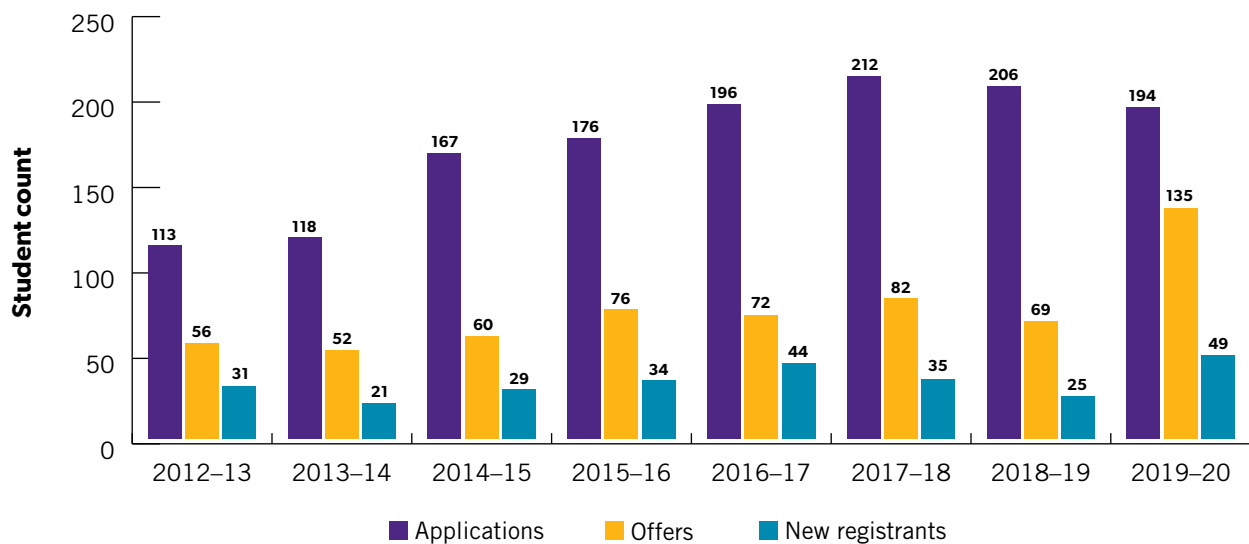

Applications, Offers, Registrations (PhD)

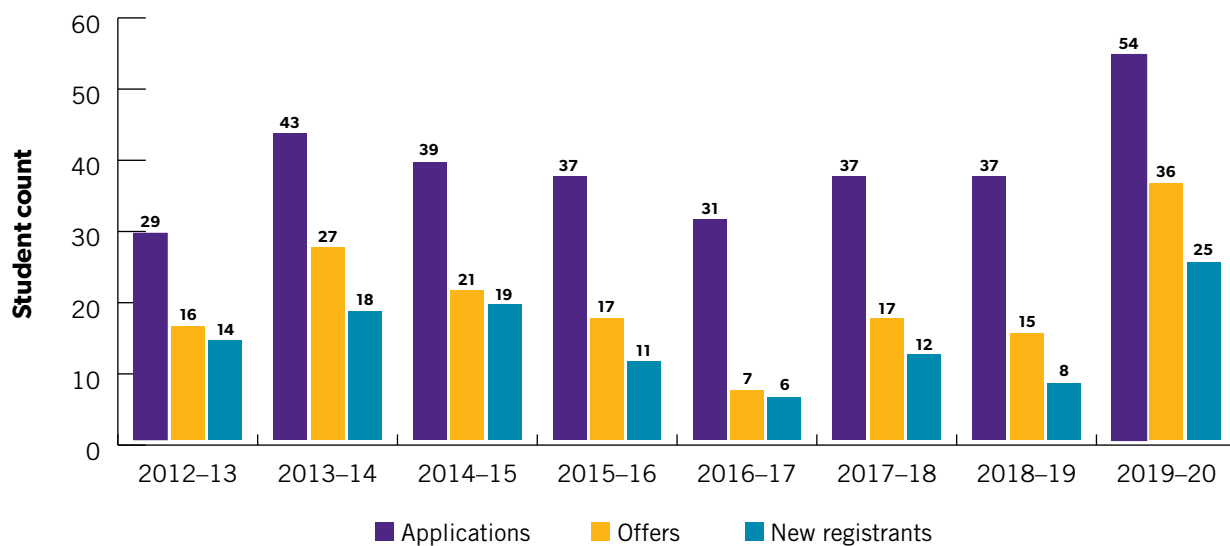

2 Research stream graduate programs

Time to completion

The average time to complete an MSc or PhD in LMP has remained steady and closely aligns with Temerty Medicine:

- MSc average 2.4 years
- PhD average 6 years

16 students withdrew from the program (2012–2020) to pursue different career paths or for personal/health reasons.

323

Students graduated from our research stream programs 2013–2020

Mean Time-to-Completion – Full-time research MSc

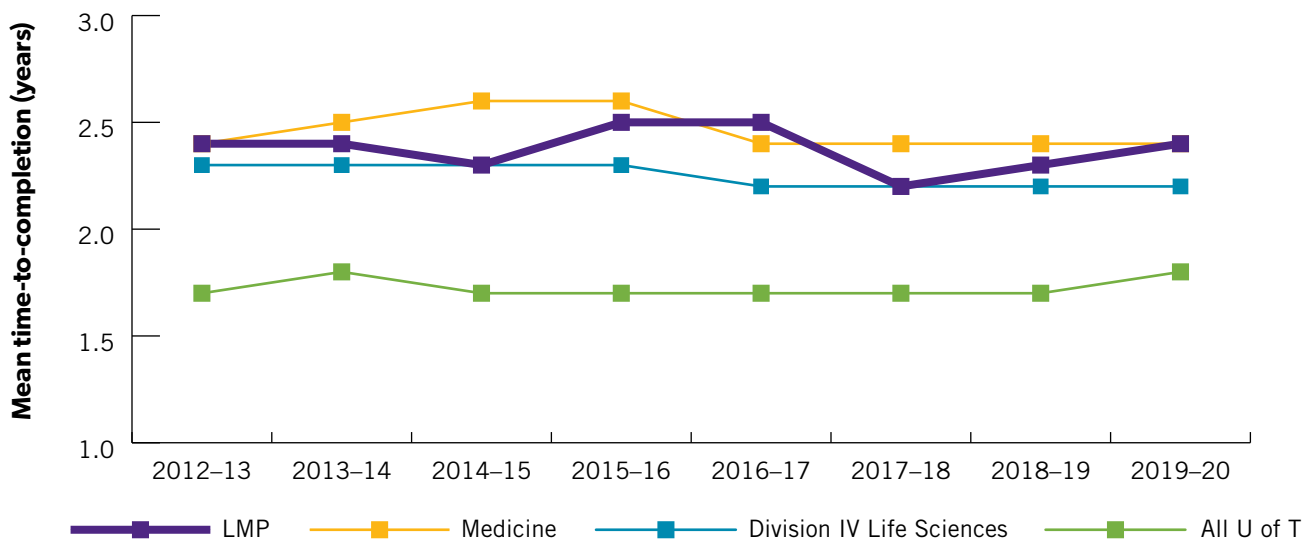

Mean Time-to-Completion – Full-time PhD

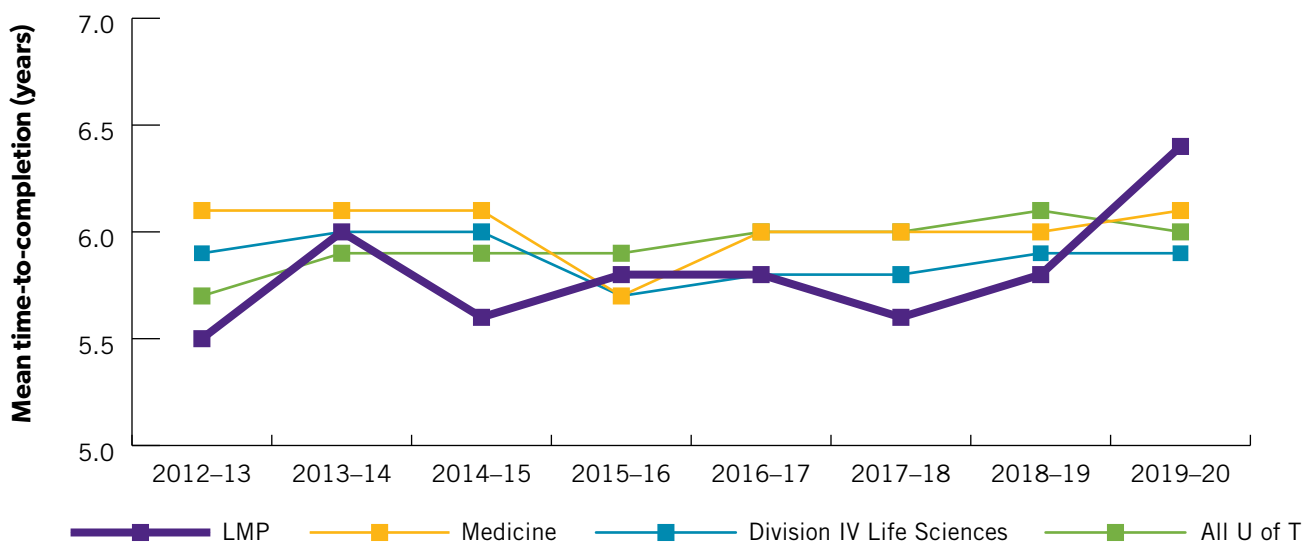

2 Research stream graduate programs

PhD satisfaction

Satisfaction for Quality of Teaching, Research Training and Career Orientation has reduced slightly over the time period.

Quality of Teaching

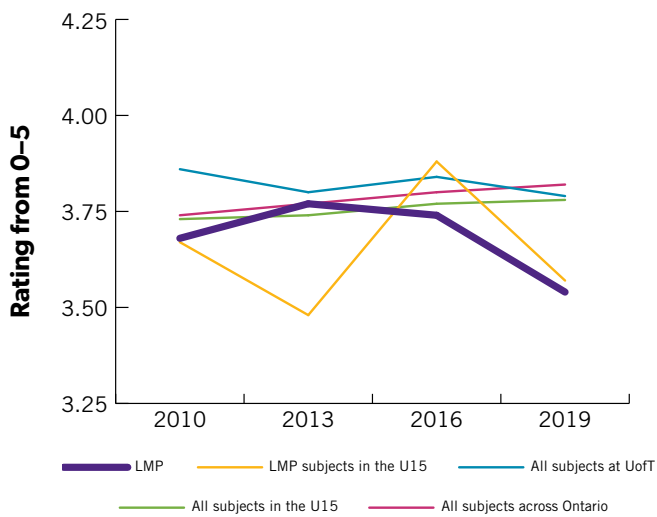

Supportive dissertative advisor

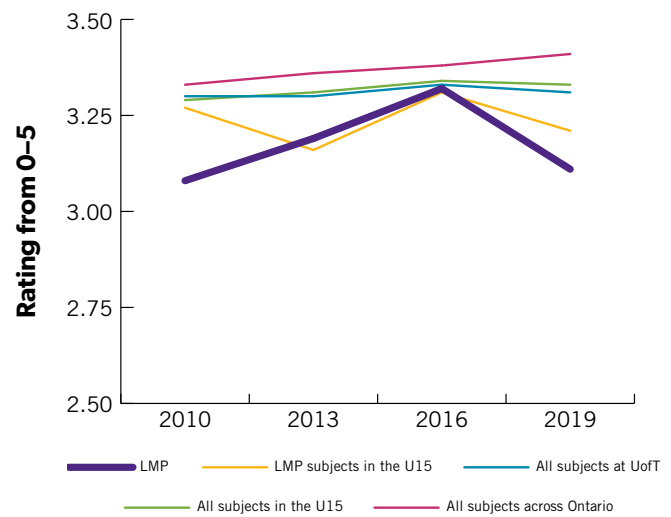

Research training and career orientation

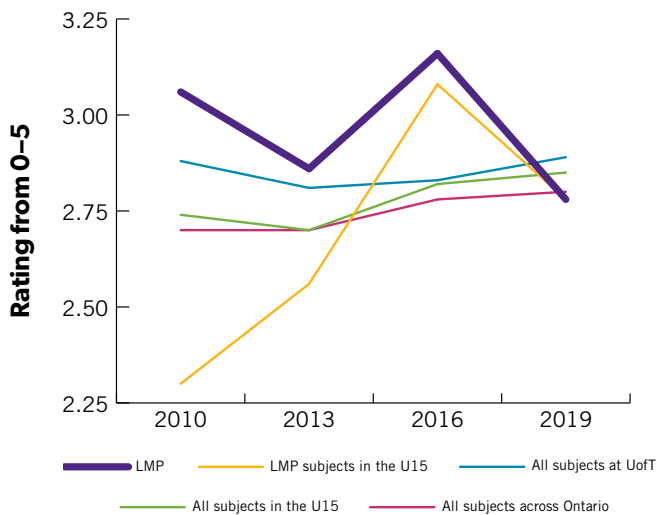



Quality enhancements

After consultations with students and faculty, we overhauled the graduate curriculum in 2020. These changes recognize the diversity of our student body in terms of undergraduate education, chosen research area, and preferred methods of learning. Our goal is to promote self-directed learning and to provide the support and resources that satisfy student needs.

Improving graduate education

The Graduate Office consulted faculty and our graduate students in town hall meetings, providing an early draft of the proposed curricular changes to the student association (CLAMPS) for feedback.

The way it was for core learning

All incoming MSc and PhD students were enrolled in 'LMP1404 Cellular Mechanisms of Disease'. This was a survey course in which each class was run by a different LMP faculty member who provided an overview of their own research field and then oversaw the analysis of primary research articles by individual students.

Feedback: The lectures on diverse topics were often not relevant to students' own research and not enough guidance was provided on how to critique research articles.

What we did: In 2020–2021, LMP1404 was replaced with 'LMP1005 Foundations of Research Practice' – a bootcamp for new graduate students on how to succeed in graduate school. This course covers good laboratory practice, the strengthening of written and oral communication skills, the use of statistical analysis, and the development of critical thinking skills.

LMP1005 is designed to help undergraduate students transition to graduate school and is, therefore, mandatory for MSc and direct-entry PhD students, but not for regular entry PhD students who have a master's degree.

The way it was for seminar courses

The Student Seminar course is mandatory for all MSc and PhD students.

All graduate students assembled in the same room each week to listen to two students present their work, ensuring students would be exposed to diverse research topics.

Feedback: Many students were frustrated at having to attend seminars on topics that were unrelated to their own research.

What we did: Students now join one of five research-themed groups. Attendance is compulsory for their group, but they can choose to attend seminars given by any of the other groups.

Class size has decreased significantly, which has promoted student participation in the question period following the seminar.

The research groups are:

1. Brain and Neuroscience
2. Cancer, Development and Aging
3. Cardiovascular, Physiology and Metabolism
4. Infectious Diseases, Inflammation and Immunology
5. Molecular and Cell Biology and Regenerative Medicine

The way it was for elective courses

Students took elective courses with 1.5 full course equivalents (FCE).

Feedback: Due to the number of elective courses required for the PhD program, students were often compelled to take courses that were unrelated to their own research.

What we did: We reduced the required number of elective courses from 1.5 full course equivalents (FCE) to 0.5 FCE. In addition to 0.5 FCE courses, the department now offers 10 new 0.25 FCE courses that allow more focused learning.

We, and other departments in Temerty Medicine have started to list 0.25 FCE courses on the University's Repository of Student Information (ROSI), our system for tracking courses, in the past year. This helps students find and enroll in courses that interest them.

Although PhD students are required to take 0.5 FCE in elective courses, they may take more elective courses if they decide this will help them achieve their educational goals.

Training in specialized techniques: The LMP Workshop Program

Our students want to learn specialized techniques. We appreciate this is important and may not be available in individual laboratories or offered in graduate courses. We considered introducing technique-based course offerings, but after recognizing the diversity of techniques our students are interested in, and the rapid pace of technological change, we did not think this would be practical.

To find a solution, we launched the [LMP Workshop Program](#). The program provides funds for students to attend local, national, and international workshops so they can receive training in specialized techniques. Funding covers registration, travel, lodging and expenses up to \$5,000.

Professional development

There is considerable student interest in professional development. Temerty Medicine provides workshops in professional development and one-on-one consultations with the Director of Mentorship and Graduate Professional Development for Research and Graduate Education, Professor Nana Lee.

In addition to these services, we launched a mentorship program in 2021 to facilitate mentoring between alumni and our current students, and a second peer mentoring program. We are using Graduway as our platform, branded Temerty Medicine Connect, to facilitate the matching and connection between alumni and current students. LMP was the second department in Temerty Medicine to join Temerty Medicine Connect. See Part 2, Mentoring, page 112.

Student Awards

The high quality of our student population and the strength of our programs is reflected in the number of external awards received. Overall, a higher percentage of LMP MSc and PhD students received external, merit-based funding compared to Temerty Medicine and the Division of Life Sciences.

Percentage of Full-time Research Master's Students with External Fellowship/Scholarship

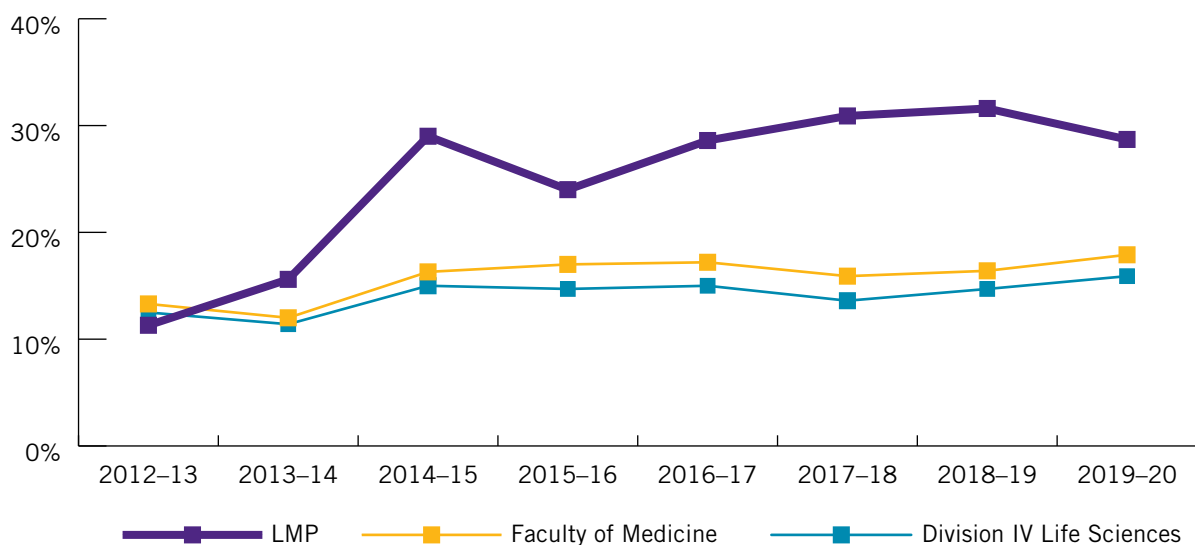

Student funding

All research stream students receive a stipend that covers tuition, fees, and a living allowance. Stipends are determined by Temerty Medicine’s Harmonized Base Funding Agreement and are paid from external awards and the supervisor’s grant funding. The stipend is guaranteed to students for the duration of their program.

Student base funding for MSc and PhD (2020–2021)

	Domestic		International	
	MSc	PhD	MSc	PhD
Living allowance	\$20,634.66	\$22,917.94	\$20,634.66	\$22,917.94
Tuition fees	\$7,769.08	\$7,769.08	\$26,519.08	\$7,769.08
UHIP	N/A	N/A	\$720.00	\$720.00
Total base funding	\$28,403.74	\$30,687.02	\$47,873.74	\$31,407.02

Students who receive external awards are given a top-up bonus over their base funding.

Award amount	Details
Up to \$2,000	Students may keep up to \$2,000 combined as a bonus above their base funding amount
\$2,001 to \$9,999 (cumulative)	Award(s) goes towards the base funding and the student receives a \$2,000 top-up over their base funding
\$10,000 to \$15,000 (cumulative)	Award(s) goes towards the base funding and the student receives a \$3,000 top-up over their base funding
Over \$15,000	Award(s) goes towards the base funding and the student receives a \$4,000 top-up over their base funding.

Graduate Travel Grant

We provide a travel grant for students who present their work at national or international conferences. Students are eligible to receive \$400 per year towards travel and conference expenses.



Response to 2013 External Review

The 2013 External Review noted that the graduate programs in LMP were ‘very well run’ but there were some areas that would further benefit the program.

Increasing faculty awareness of and involvement in the graduate program

The Review recommended that faculty members were regularly made aware of the various processes and procedures, and more faculty members engaged in the management of the program.

We consulted faculty to implement the curriculum changes in 2020 and recruited junior faculty to teach in the newly formed modules.

We overhauled the graduate section of our website to present procedures related to admissions, program requirements, thesis advisory committees, courses, and program completion more clearly: [LMP Graduate webpage](#).

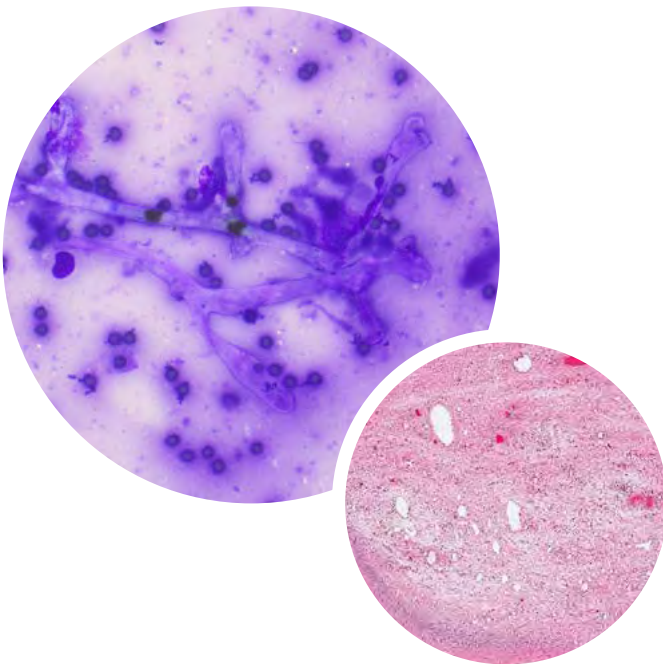

International student fees

As international students have to pay a significant differential fee, this limits the number of faculty who can fund such students.

High international tuition fees prevented some faculty members from hiring international graduate students. Since then, Temerty Medicine has decreased international tuition for PhD students so it is now in line with that of domestic students. The number of international graduates increased this year.

The tuition for international MSc students remains higher than that of domestic students, but we do not have the ability to make changes to tuition fees or the budget to subsidize international MSc students.

Funding pressures for the program

Reduced research grant funding may pose additional pressure on the program and LMP could explore establishing a “rainy day funds” for such circumstances.

Attaining stable funding continues to be a challenge, so a number of our faculty have benefitted from internal financial need initiatives.

Doctoral students may apply to the University’s Doctoral Completion Award if the supervisor experiences budgetary stress. This is administered by LMP and covers a student’s stipend from one to three terms depending on need. We also have a budget to support MSc students that can no longer be supported by their supervisors.

In addition, Temerty Medicine has recently launched a Pathway Grant program to provide \$100,000 in bridge funding to each of the three highest ranking unfunded CIHR proposals in each competition. See Part 2, Research, page 10.



3

Life Sciences Education

Undergraduate A&S Specialist Program in Pathobiology

The Pathobiology Specialist Program is a life science undergraduate program in the Faculty of Arts & Science, focused on providing our students with a strong education in the basic mechanisms of pathobiology while demonstrating how they impact human health and disease.

The program focuses on disease mechanisms and differs from medical pathology by emphasizing biological changes and disease mechanisms rather than disease recognition or diagnosis. The program curriculum and delivery necessarily follow a multidisciplinary approach.

Our department offers expertise in various bench-to-bedside settings, from basic molecular studies to whole organism biology, infectious disease, epidemiology, and clinical trials. Students are exposed to all these levels through theoretical and experiential learning features, but the didactic focus of the formal program is on cellular and molecular mechanisms.

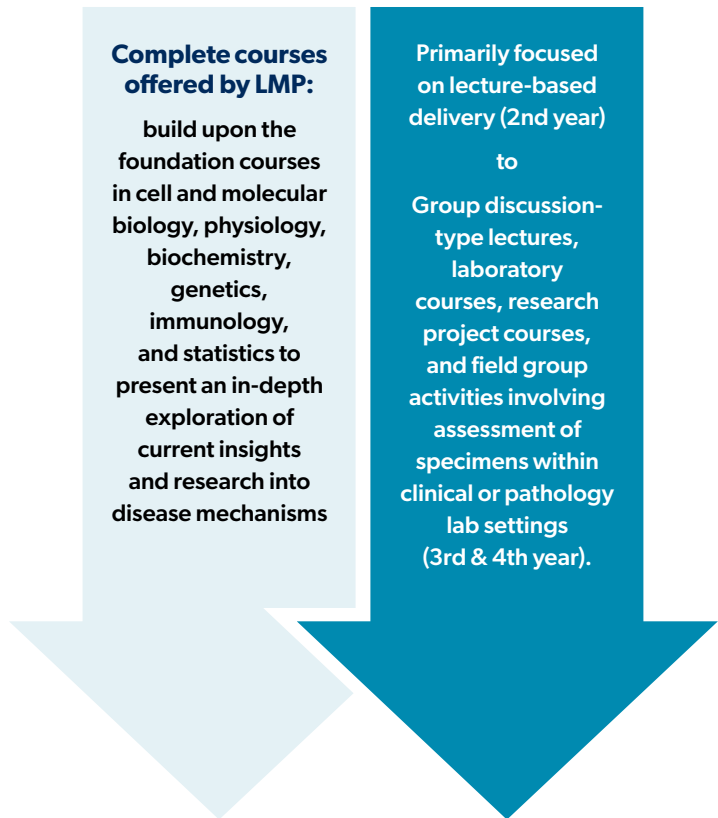
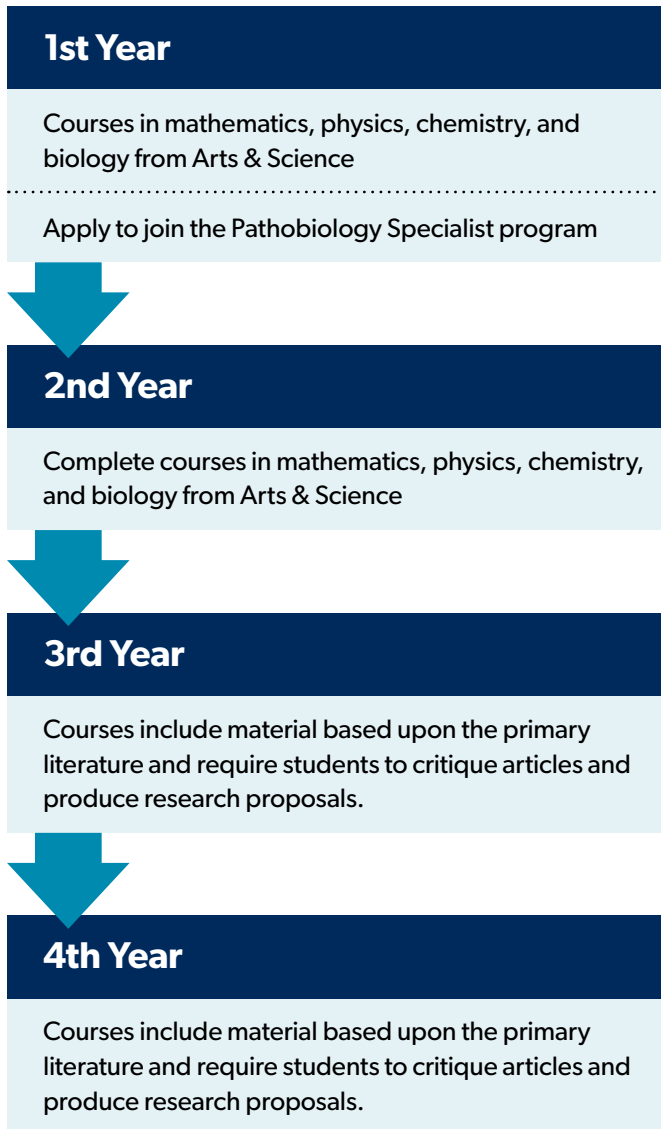

Our alumni



Our alumni have careers in

- academia
- governmental agencies
- education
- biomedical, biotechnology, and pharmaceutical industries
- and more

*based on a sample of 90 students tracked by our alumni office

3 Undergraduate A&S Specialist Program in Pathobiology

The Pathobiology Specialist program was founded in 2001 by Dr. Doug Templeton and Dr. Avrum Gotlieb, and the program underwent several minor modifications over the following two decades. During that period, the program has consistently attracted high-performing and diverse students and accommodated up to 30 students per academic year.

The overarching objective of the Pathobiology Specialist program is to provide learners with a world-class foundational education in the mechanisms and processes underlying human health and disease.

Our students gain this through theoretical and experiential learning and by the breadth/depth of the expertise of our departmental faculty members from the campus and affiliated hospitals and institutes.

This foundation ensures our students continually succeed in their next career step, which is usually graduate studies and often in professional education such as medicine.

Our program, especially with its recently updated curriculum (see below), provides students with a higher ability to personalize the program to better prepare for the following specific career step.

- For those who will pursue graduate research, our objective is to produce a graduate who can function as a high-level MSc or PhD student.
- For the graduates who choose medical school, we aim to give a deeper understanding of the scientific foundations of medicine and equip learners to use their future clinical environment to advance the science of diagnosis and treatment.

Developing the curriculum

To ensure the program's continued success, since becoming the Co-Associate Chairs and Coordinators of the Pathobiology Specialist Program in April 2019, Dr. Karim Mekhail and Dr. Jeffrey Lee initiated an extensive series of consultations in 2019-2020 with students and faculty, both within our department and with other departments or units across the university.

Based on the feedback, they proposed curriculum modifications in late 2020 which were approved in early 2021. The program updates will be gradually introduced, starting with the entering class of Fall 2021. Second-year

changes will take effect beginning in the 2021-2022 academic year, while the third- and fourth-year changes will take effect in the 2022-2023 academic year.

Overall, the approved changes are well aligned with the broader plan of our department to expand efforts within areas such as big data and computational biology/medicine, infectious diseases, metabolic disorders, developmental/stem cell biology, and our overall departmental goal to investigate disease and impact health.

The changes have enabled us to:

- **Modernize the curriculum:** we removed outdated courses and introduced several modern techniques, including bioinformatics and computational medicine and major biomedical areas such as metabolic disorders, stem cells in developmental biology regenerative medicine, and related organoid systems.
- **Improve cohesion, integration, and personalization by:**
 - » designing new third- and fourth-year courses to transition learners from introductory to advanced material logically and minimize the number of lecturers per course by adopting a course module system.
 - » expanding course options to allow students to cover several topics equally or focus more on specific areas of knowledge.
 - » introducing a second-year course providing students with an early foundation in pathobiology while better integrating them into our robust departmental community.
- **Expand experiential learning** by introducing an innovative experiential learning research course.

Learning outcomes

Depth and breadth of knowledge

We aim to provide a broad understanding of contemporary medical research and the fundamental scientific underpinnings that have revolutionized our understanding of disease and its treatment.

The program emphasizes the areas of pathology (nature of changes produced by disease), pathogenesis (mechanisms and changes in disease that occur at the molecular, cellular, and tissue level), and pathophysiology (changes in organ and system functions that accompany disease).



We expect our students to:

1. Gain an understanding of advanced subject material related to the mechanisms of disease
2. Use scholarly material and research tools relevant to the disease field of study
3. Produce inquiry-based works
4. Appreciate the varied modes of thinking, methods of inquiry, and analysis
5. Understand how various areas of study intersect and allow for complementary insights into disease processes.

Achieving this learning outcome

- The recently approved, early introduction of pathobiology concepts start in the second year (as part of the 'LMP200H1 Pathobiology of the Cell' course), as opposed to the third year, will better integrate students' knowledge of the biological and physical sciences into an understanding of the function and dynamics of the cell in the context of health and disease.
- The addition of three core/transitional third year LMP courses ('LMP310H1 Foundations of Pathobiology', 'LMP320H1 Pathobiology of Stem Cells', and 'LMP330H1 Genetic and Computational Modeling in Human Development and Disease') introduce students to fundamental principles involved in different diseases, preparing the learners for the advanced fourth-year courses focusing on specific types of diseases and disorders.
- In the fourth year, students take at least four courses in specialized areas of Pathobiology (e.g., 'LMP410H1 Pathobiology of Neurodegenerative Diseases', 'LMP415H1 Forensic Pathobiology', 'LMP420H1 Cancer Pathogenesis', 'LMP430H1 Metabolic Disorders', 'LMP440H1 Mechanisms in Host-Microbe Interactions', 'LMP450H1 Organogenesis in Health and Disease', and 'LMP460H1 Pathobiology of the Cardiovascular System'). By taking four different courses focusing on diverse diseases, students will obtain complementary insights into the various disease processes. In particular, the recently added LMP430H1 and LMP450H1 courses improve the breadth and depth of the disease-related courses.

- Metabolism and human development are two of the nine areas of strategic research and education importance to our department. Both these areas have been historically under-represented in our program. However, the new program will now expand these areas while ensuring the vertical integration of knowledge advancement across academic years and allowing students to develop essential connections between theoretical and experiential learning.
- The new 'LMP305Y1 Pathobiology Research Analysis & Project' course introduces students to experimental design through hands-on research while teaching the fundamentals of logic/argument, statistics, and data analysis. The combination of teaching the theoretical principles of research with the experiential learning component of the course will help students critique and analyze scientific literature.

Knowledge of methodologies

Our students will be able to develop a working knowledge of different methodologies and approaches relevant to their field and justify their choice of methods in their research.

Achieving this learning outcome

- The program includes second-year statistics courses (STA220H1 or STA288H1), allowing students to become familiar with modern statistical approaches and software used to conduct descriptive and inferential statistics to address basic life sciences research questions. Such courses provide students with a foundation to apply proper statistical analyses in their research.
- The 'LMP330H1 Genetic and Computational Modeling in Human Development and Disease' third-year course enables students to explore the different genetic model systems, bioinformatics and computational approaches, and biological and disease data analysis methods. This course allows students to understand better the genetic and animal models used when carrying out research paper critiques in fourth-year courses.
- The new 'LMP305Y1 Pathobiology Research Analysis & Project' course contains a lecture-based component designed to provide students with the methodological and analytical skills required to be successful scientists. Topics include good lab practice, experimental design, statistics, and data analysis. Students then further develop their knowledge of methodologies through the LMP405Y1 course, which allows them to conduct a more substantial research project throughout the academic year.

Application of knowledge

Our students will be able to apply their knowledge and understanding within the context of research projects, ask questions relevant to their fields, formulate hypotheses, design inquiry strategies, craft solutions to problems, collect the appropriate data, and develop compelling arguments.

Achieving this learning outcome

- Several courses (e.g., 'LMP200H1: Pathobiology of the Cell') feature critical essay assignments on unresolved scientific topics, and students are requested to build arguments on dozens of references from recent scientific literature. This approach requires a significant amount of independent study over a couple of months while digesting the relevant coursework. Regular tutorials outside of class time are provided to cover issues related to scientific publishing, citation, and critical review, at the appropriate times through the terms.
- The research project courses LMP305Y1 and LMP405Y1 enable students to analyze and evaluate data in published manuscripts and develop basic logic/arguments. These courses also provide undergraduate students with invaluable research experience under the direct guidance of our experienced faculty members.
- Lecture-based courses often include hands-on visits to research or clinical settings allowing students to experience diverse real-world applications knowledge. For instance, the new course ('LMP450H1: Organogenesis in Health and Disease') incorporates a group activity consisting of a visit to a hospital-based stem cell lab to demonstrate how stem cell-generated organoids are used to diagnose, model, and treat certain diseases today.

Communication skills

Our students will be able to organize ideas into coherent arguments supported by appropriate evidence and communicate that information verbally or in writing a manner most suited to the specific audience or context.

Achieving this learning outcome

- Various second, third, and fourth-year courses (e.g., LMP200H1, LMP305Y1, LMP310H1, LMP320H1, LMP330H1, LMP405Y1) require students to present thoughtful interpretations of subject material or research results in terms of papers, essays, proposals, tests, exams, debates, or oral presentations.
- The LMP305Y1 research course specifically covers the theory and practice of oral and written communication skills.
- Fourth-year research course students present their research results at various stages of their research project and receive constructive feedback on how to improve their written and oral communication skills.

Awareness of limits of knowledge

Our students can identify the limits of knowledge in each field and appreciate how uncertainty and ambiguity might influence analyses and interpretations.

Achieving this learning outcome

- Several courses (including LMP200H1, LMP310H1, LMP320H1, LMP330H1, and especially fourth-year courses such as LMP410H1, LMP415H1, LMP420H1, LMP430H1, LMP440H1, LMP450H1, and LMP460H1) expose students to the current state of knowledge in various fields. Students understand the limits of knowledge and how little we know about specific disease processes through the lectures and interactive components of such courses. For instance, 'LMP330H1 Genetic and Computational Modeling in Human Development and Disease' includes team debates in which students discuss whether high-profile research manuscripts did solve a significant gap in different fields or whether the studies provided a partial step forward. In addition, by partaking in experiential learning opportunities such as the LMP305Y1 and LMP405Y1 research project courses, students see first-hand the limits of our understanding of disease processes when engaging in independent research projects under the guidance of leading researchers.



Autonomy and professional capacity

Our students develop a sense of independent inquiry and gain professional competencies critical for future graduate or professional education or the job market.

Achieving this learning outcome

- Our departmental chair, program associate chairs and coordinators, teaching faculty, and teaching assistants all engage students in teaching and social settings within the frame of our departmental guidelines of professionalism and respect. This social and professional background sets the right example for learners.
- Our research courses (LMP405Y1 and LMP305Y1) provide students with the opportunity to work both autonomously and within a team within the professional setting of a research laboratory.
- LMP305Y1 covers several professional soft skills, including written/oral communication, experimental design, statistical perspectives, and deductive/inductive reasoning.
- Several of our courses (e.g., LMP200H1 and LMP330H1) explore the ethics of animal research, genetic manipulation, and disease modeling. This profound insight into biomedical ethics will be crucial for students looking to pursue professional/academic careers as researchers, physicians, or physician-scientists.

Admission requirements

This is a limited enrollment program – eligibility is competitive with a targeted enrollment of 35 students per year.

Students need a minimum grade or average in required courses or their equivalents. This minimum changes each year depending on the number of applicants and available spaces, partly dependent on general agreements between the Faculty of Arts & Science and the Temerty Faculty of Medicine.

Students must complete:

- 4.0 university-level credits; and
- the following courses:
 1. [BIO120H1](#): Adaptation and Biodiversity and [BIO130H1](#): Molecular and Cell Biology;
 2. ([CHM135H1](#): Chemistry: Physical Principles and [CHM136H1](#): Introductory Organic Chemistry I) or [CHM151Y1](#): Chemistry: The Molecular Science;
 3. ([MAT135H1](#): Calculus I and [MAT136H1](#): Calculus II) or [MAT137Y1](#): Calculus with Proofs or [MAT157Y1](#): Analysis I.

We determine eligibility from the underlying numeric final mark in each of the required courses.

We will consider applications from students lacking numerical grades in one or more of the specified prerequisites, or students applying in their second or later years, based on their entire academic record and space availability. In such cases, students contact Dr. Karim Mekhail and Dr. Jeffrey Lee for specific advice.

All admission requirements reflect the guidelines set out in the [Arts & Science Program Toolkit](#), which is accessible to prospective students.

Program requirements

Students must complete 14.0-15.5 credits, including at least 2.0 credits at the 400-level. On the next page is a list of all courses offered as part of the program, and the syllabi for all courses are attached in Appendix 1.3.1.

3 Undergraduate A&S Specialist Program in Pathobiology

First Year

- [BIO120H1](#) Adaptation and Biodiversity
- [BIO130H1](#) Molecular and Cell Biology
- [CHM135H1](#) Chemistry: Physical Principles and
- [CHM136H1](#) Introductory Organic Chemistry I; or
- [CHM151Y1](#) Chemistry: The Molecular Science
- [MAT135H1](#) Calculus I and
- [MAT136H1](#) Calculus II; or
- [MAT137Y1](#) Calculus with Proofs; or
- [MAT157Y1](#) Analysis I.

First or Second Year

- [PHY131H1](#) Introduction to Physics I and
- [PHY132H1](#) Introduction to Physics II; or
- [PHY151H1](#) Foundations of Physics I and
- [PHY152H1](#) Foundations of Physics II

Second Year

- LMP200H1 Pathobiology of the Cell
- [BCH210H1](#) Biochemistry I: Proteins, Lipids and Metabolism
- [BIO230H1](#) From Genes to Organisms
- [BIO260H1](#) Concepts in Genetics; or
- [HMB265H1](#) General & Human Genetics
- [CHM220H1](#) Physical Chemistry for Life Sciences
- [CHM247H1](#) Introductory Organic Chemistry II; or
- [CHM249H1](#) Organic Chemistry
- [PSL300H1](#) Human Physiology I
- [PSL301H1](#) Human Physiology II
- [STA288H1](#) Statistics and Scientific Inquiry in the Life Sciences; or
- [STA220H1](#) The Practice of Statistics I; or
- [BIO220H1](#) From Genomes to Ecosystems in a Changing World

Third Year

- BCH370H1 Laboratory Course in Biochemical Techniques
- BCH311H1 Biochemistry II Nucleic Acids and Biological Information Flow
- LMP310H1 Foundations of Pathobiology
- LMP320H1 Pathobiology of Stem Cells
- LMP330H1 Genetic and Computational Modeling in Human Development and Disease

Plus, students must choose at least one of the options below. If the research course LMP305Y1 is taken, an additional option from the list is still required.

Option A: Immunology

- [IMM340H1](#) Fundamental Immunology and
- [IMM350H1](#) The Immune System in Action; or
- IMM341H1 Fundamental Immunology (Advanced) and
- IMM351H1 The Immune System in Action (Advanced)

Option B: Microbiology

- [MGY377H1](#) Microbiology I: Bacteria
- [MGY378H1](#) Microbiology II: Viruses

Option C: Anatomy

- [ANA300Y1](#) Human Anatomy and Histology

Option D: Metabolic and Signaling Pathways

- [PSL425H1](#) Integrative Metabolism and its Endocrine Regulation
- PCL386H1 Pharmacology of Cancer Signaling

Option E: Research

- LMP305Y1 Pathobiology Research Analysis and Project

Fourth Year

Students choose four 400-series courses (2.0 credits). If the research course LMP405Y1 is taken, an additional three 400-series courses from the list are still required (total 2.5 credits).

- [LMP405Y1](#) Project in Pathobiology
- [LMP410H1](#) Pathobiology of Neurodegenerative Disease
- [LMP415H1](#) Forensic Pathobiology
- LMP420H1 Cancer Pathogenesis
- LMP430H1 Metabolic disorders
- LMP440H1 Mechanisms in Host-Microbe Interactions
- LMP450H1 Organogenesis in Health and Disease
- LMP460H1 Pathobiology of the Cardiovascular System



Curriculum design

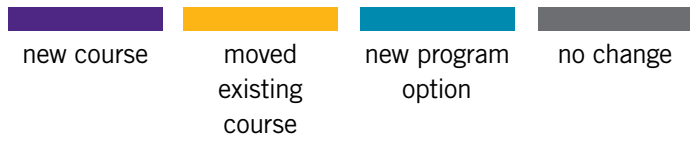

- 14.0-15.5 credit requirement
- at least 4 courses from 4th year

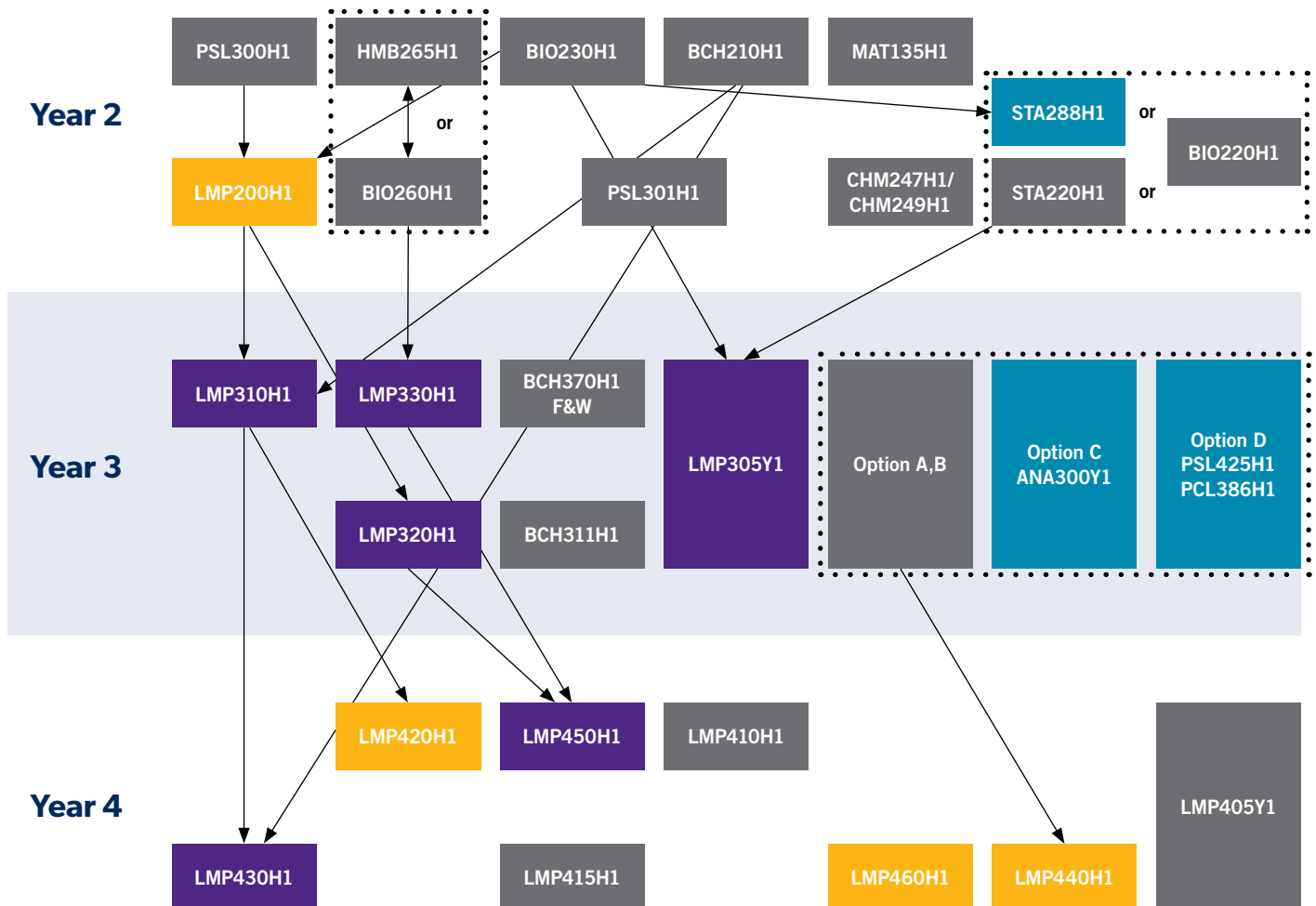
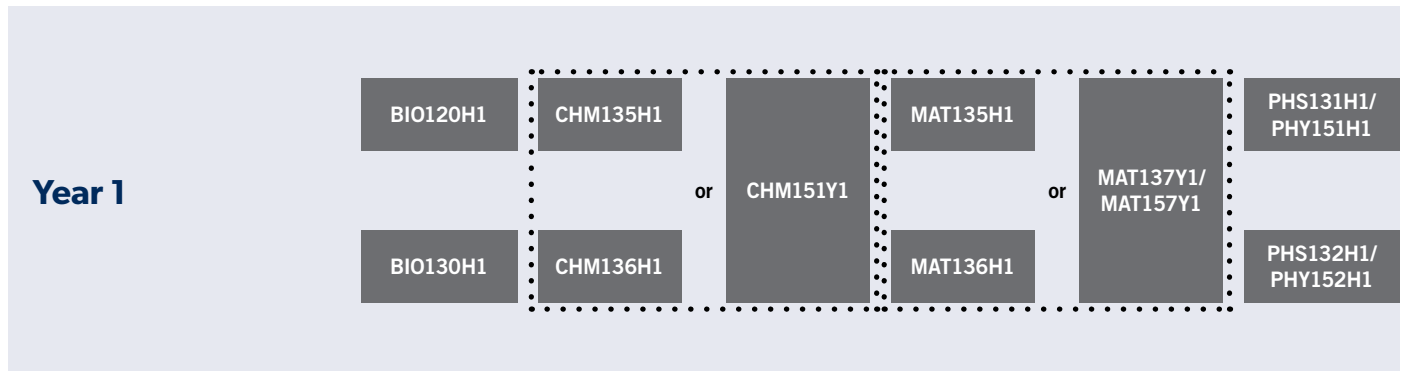

3 Undergraduate A&S Specialist Program in Pathobiology

The overall design of the curriculum has been greatly strengthened and clarified following the recently approved changes.

Strengths of the new curriculum include modern updated material, logical transition in the material covered from introductory to advanced, and increased personalization, allowing our students to custom-tailor their studies to best prepare for the next step of their career.

Specifically, the updated curriculum provides:

- Reorganization of courses to further enhance the student experience and learning outcomes.
- An earlier introduction to the concepts of pathobiology through the addition of a second-year pathobiology course ('LMP200H1 Pathobiology of the Cell') to understand concepts and prepare for further study of major molecular mechanisms and biomedical research work in the third year.
- In the third year, new courses were introduced (LMP310H1, LMP320H1, LMP330H1) to equip students with the fundamentals and knowledge of models needed to study specific diseases the following year. Students also gain the opportunity to pursue at least one of five options/pathways depending on their area of interest.
- In the fourth year, students benefit from various courses to study different diseases and disorders. The course restructuring and renumbering were also meant to assist students with pathfinding (e.g., LMP420H1 focuses on cancer; LMP430H1 focuses on metabolic disorders; LMP440H1 focuses on host-microbial interactions; LMP450H1 focuses on organogenesis; LMP460H1 focuses on the cardiovascular system).
- Increased experiential learning options at the third-year level (LMP305Y1). Our surveys show that over 50% of our Pathobiology Specialist students go on to graduate school and that many of our students are looking for third-year research opportunities. This new research course will provide a guided introduction to research and help better prepare students for conducting research in the fourth year and beyond.
- Introduced new pathobiology courses that are well aligned with the research strengths of the department and faculty (e.g., computational biology/medicine, metabolic disorders, developmental/stem cell biology, cancer pathogenesis, organogenesis/regenerative medicine, big data)

During the COVID-19 pandemic, our courses moved to a virtual online delivery or hybrid model depending on the specific courses. Laboratory courses were offered in person while lecture-based classes became virtual. We will begin a phased return to in-person teaching starting Fall 2021.

Experiential learning opportunities

We have 390 research active faculty members, 40–60 of whom take research undergraduate students each year. Thus, the Pathobiology Specialist students have many different experiential learning and funding opportunities to carry out research in our program.

Summer research: the LMP Summer Undergraduate Research Experience (SURE)

All students admitted to the SURE program are guaranteed a stipend from their supervisor (minimum \$4,800). In addition, the department (via funding from Temerty Medicine) offers ~15 competitive scholarships worth \$2,000 each year.

We have also created six LMP SURE Early Awards, which are restricted to our second and third-year Pathobiology Specialist students. These summer scholarships (\$2,000) are awarded in January and designed to allow students to secure a summer lab research position. This past summer we supported two undergraduate students from racialized groups to have a research experience in a supportive environment. See more about about Black and Indigenous student initiative in Part 2, Wellness, Inclusion, Diversity & Equity, page 61.

SURE at a glance

Runs May–August for 12 weeks

38-59 students attend the program each year

[LMP Summer Undergraduate Research Experience Program \(SURE\) webpage](#)



Work-study

The work-study program is a U of T administered program where over 3,500 students participate in paid, on-campus positions that provide an opportunity to deepen knowledge, strengthen skills or explore how academic courses translate to career possibilities. Work-study positions are paid minimum wage (\$15/hour), with 70% covered by the university and the remaining 30% covered by the faculty supervisor.

Many of our faculty participate in this program and offer work-study positions to our students where they work in a research lab preparing reagents and/or carrying out general lab tasks. These are excellent entry-level positions for second-year students to obtain research experience. Many students continue after the work-study program with summer research or a research course with the same lab and research supervisor.

[Student Life webpage](#)

Research opportunity courses

LMP299Y1/LMP399Y1 are year-long research courses for second and third-year Pathobiology Specialist students. This course is organized by the Research Opportunities Program in the Faculty of Arts & Science.

LMP faculty who take on LMP299Y1/LMP399Y1 students receive between \$750 to \$2,000 to cover expenses for research consumables/supplies. This opportunity will be extended to those faculty who take on students from our Black and Indigenous summer research program.

Hybrid research course

LMP305Y1 is the new third-year research course (starting in 2022–2023). This course is designed to introduce third-year students to biomedical research and provide them with the analytical skills required to be successful scientists.

Students will have the opportunity to carry out a full-year research project under the supervision of an LMP faculty member (6–8 hours/week in the lab). Lectures cover laboratory practice, experimental design, basic logic/argument, statistics, data analysis, and scientific communication. The fundamentals taught in these lectures will be used to critique and analyze scientific literature.

Research course

LMP405Y1 is the primary research project for Pathobiology Specialist students. Students carry out a research project under the supervision of an LMP faculty member.

Students write a 30- to 40-page report in the form of a thesis or research paper. They will give a final oral examination, where they deliver a 10-min presentation followed by an oral defense of their work to a three-member panel usually consisting of their supervisor, the LMP405Y1 course coordinator, and an external examiner.

Student-faculty interaction

A key priority for our program is to promote strong student-faculty interactions:

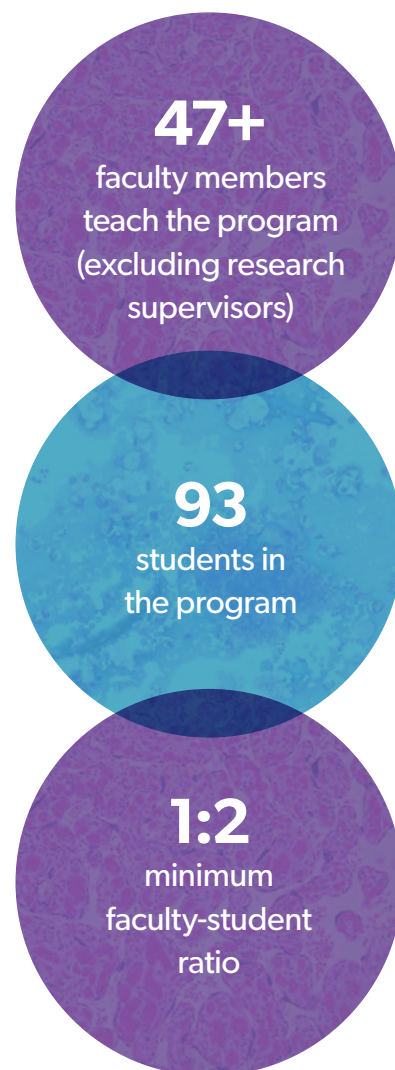

3 Undergraduate A&S Specialist Program in Pathobiology

Small class sizes

Our classes are small by U of T standards (generally under 35 students in courses offered by our department), thus facilitating daily student-faculty interaction. In the new curriculum, almost all courses have a tutorial component, allowing for additional small group interaction and activities with professors and Teaching Assistants (TAs). Our courses offer substantial opportunities for our students and faculty to get to know each other.

Discussion-based classes

The majority of our 400-level courses have small group discussion activities, usually focused on critiquing assigned research publications. Other courses, such as our new LMP330H1, offer interactive debates discussing high-profile research papers and their contribution to the field.

Open-door policy

Our Medical Science Building-based course coordinators and Undergraduate Office are easily accessible as their offices are in unrestricted areas of the building. This ease of access allows professors to offer an open-door policy, where students can drop in to ask questions or seek advice. Instructors located at the hospital institutes, or the MaRS research tower are all within a 10-minute walk from the main campus and accessible.

Departmental events

The Pathobiology Specialist students have a standing invitation to attend our weekly Monday Seminar Series (see Part 2, Research, page 10) and Graduate Student seminars (see Research stream graduate program, [page 28](#)). We also hold a Wednesday coffee break for faculty, staff, postdocs, graduate, and undergraduate students.

Such events provide informal settings for our Pathobiology Specialist students to meet faculty members and graduate students.

Undergraduate student events

The LMP Student Union (LMPSU) is highly engaged with its members and the department. In addition to holding its own social and academic events, LMPSU invites faculty to student elections, hosts faculty events to meet 2nd-year students, arranges professional school admission workshops, and hosts regular academic Pub n' Pub seminars. Such seminars are unique events where faculty speak on a timely research topic before joining students in an outing to a restaurant where they can further engage the faculty speaker, learn more about the research, and seek career advice. For example, Dr. Michael Ohh gave a thought-provoking talk on the research behind the discovery of hypoxia sensing after the Nobel Prize in Medicine was awarded to Drs William Kaelin, Peter Ratcliffe, and Gregg Semenza and Dr. Phedias Diamandis gave a talk about AI in medicine.

LMPSU organizes a highly successful undergraduate conference every January. LMPSU selects the topic and invites LMP and other U of T faculty to present their research. To the credit and hard work of the students, this event is highly attended. This is one of the premier undergraduate conferences at our university.

2021 LMPSU Conference – COVID-19: Investigating a viral phenomenon.

700+ faculty and students registered to attend

[Undergraduate conference shows laboratory medicine's role in understanding, diagnosing and treating COVID-19](#)





Assessment of learning

Most undergraduate Life Sciences students at U of T experience large classes and multiple-choice tests in their first two years of science courses. We break this pattern in our program by maintaining small class sizes and evaluating critical thinking and hypothesis evaluation. Evaluation requirements are given for most courses in the syllabi in Appendix 1.3.1.

Based on the premise that if our students can communicate clearly, they think clearly, we allow them to do so by using examinations and tests that involve short-answer or essay-type questions in all courses.

Other means of evaluation in our various courses include:

- critical essays, article critiques, presentations, or group activities (LMP310H1, LMP320H1, LMP330H1, LMP410H1, LMP415H1, LMP420H1, LMP440H1, LMP450H1)
- lab tests (CHM247H1/CHM249H1, BCH370H1, LMP420H1)
- research proposals (LMP410H1, LMP460H1)
- research works (LMP305Y1, LMP405Y1)

These various modes of evaluation serve two purposes: the instructors can evaluate the level of student comprehension and function in the variety of ways needed for further productive study, and the students are given multiple opportunities to reveal their knowledge.

Quality indicators

Program enrollment

Annual enrollments for Undergraduate Specialist Program

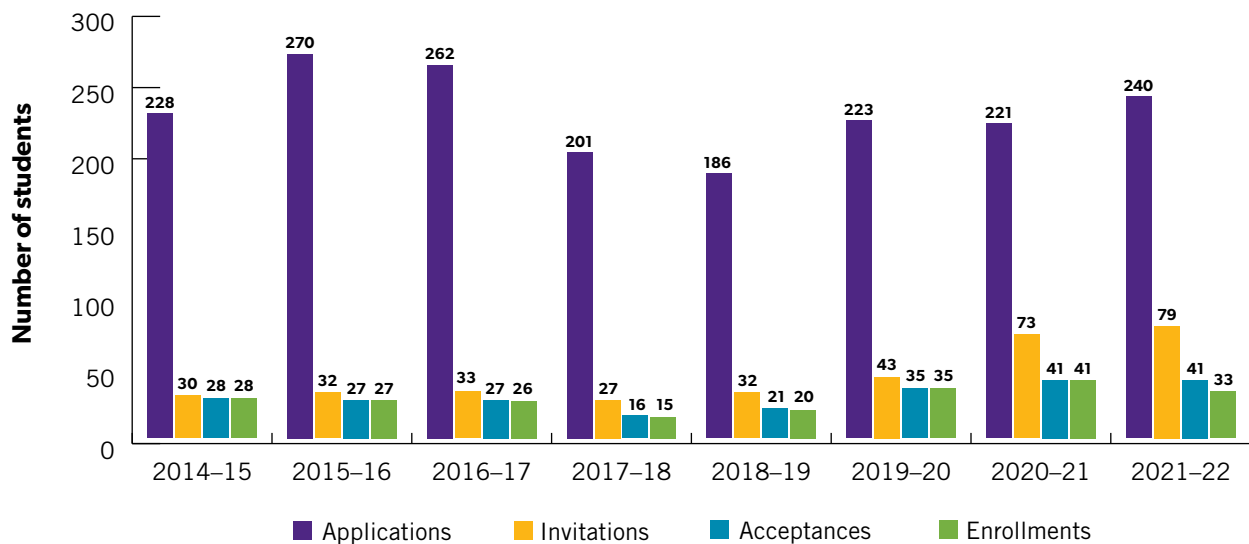

In 2019, our new undergraduate coordinators improved the curriculum and expanded our recruitment outreach and program visibility to students. Since 2019, we have >33 students registered per year which is the maximum approved capacity for our program.

3 Undergraduate A&S Specialist Program in Pathobiology

Grade averages

Students enter our program in their second year but the mean cGPA and percentages of their first-year courses are not officially available from the university. We have our own departmental statistics based on the grades used for admissions into the program. In the past two years, students invited into the program had a minimum 88% average in their prerequisite first-year courses - the highest cutoff value amongst all basic medical science programs.

Final year grade point averages

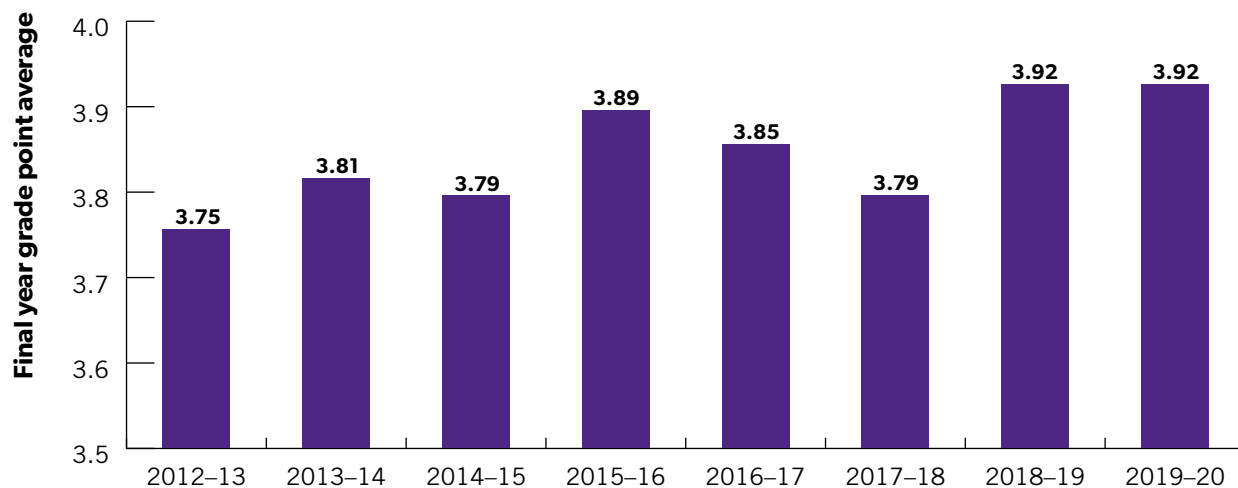

Throughout the history of the Pathobiology Specialist program, our students are consistently graduating at the highest academic level in the Faculty of Arts & Science.



Course evaluations

Course evaluations are carried out by the Faculty of Arts & Science using online surveys. While the use of online evaluation surveys is convenient, often the response rate is low (25 - 35%).

The data includes students in two large courses offered by our department (LMP301H1 and LMP363H1), which are required for other programs at U of T, but not for our Pathobiology Specialist students.

Q1: I found this course intellectually stimulating

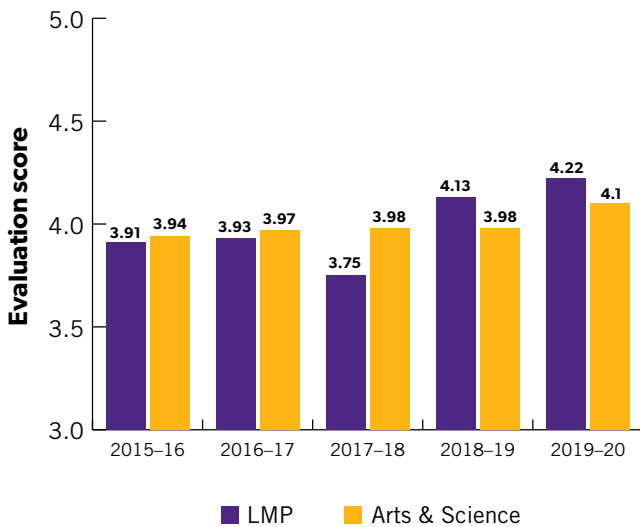

Q2: The course provided me with a deeper understanding of the subject matter

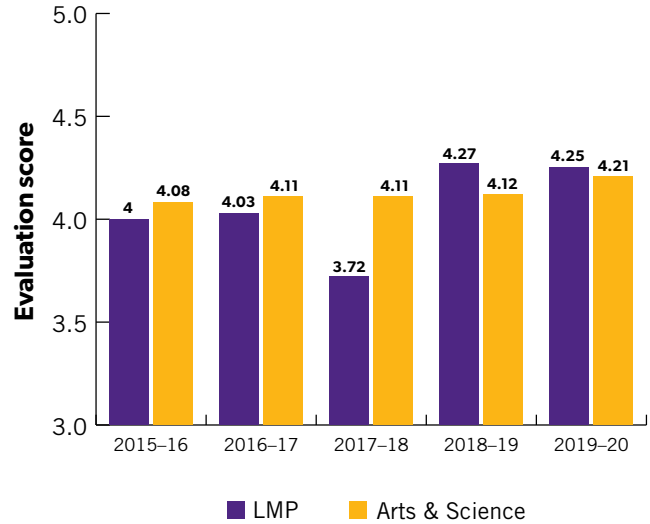

Q3: The instructor created an atmosphere that was conducive to my learning

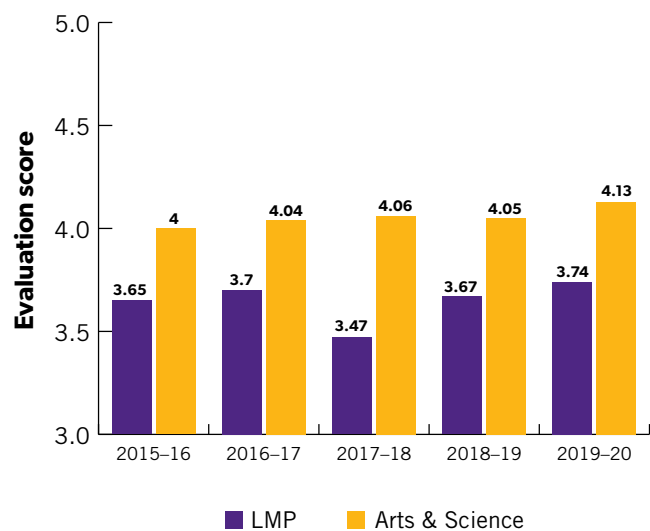

Q4: Course projects, assignments, tests, and/or exams improved my understanding of the course material

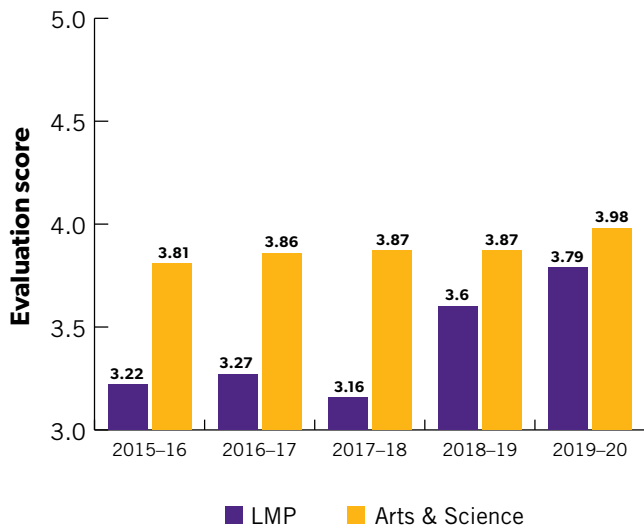

Q6: Overall, the quality of my learning experience in this course was

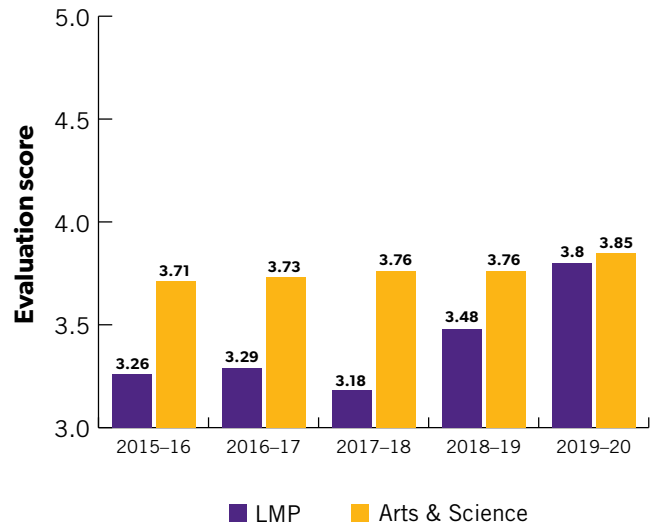

Q5: Course projects, assignments, tests, and/or exams provided opportunity for me to demonstrate an understanding of course material

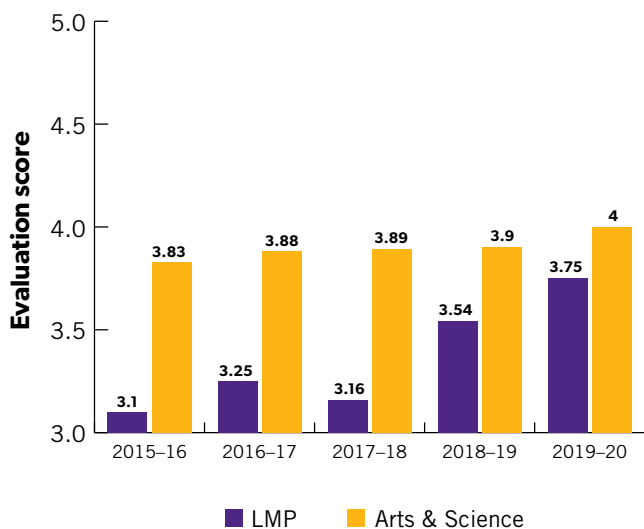

Overall, the course evaluation data indicate a general level of satisfaction among our students, in line with the overall averages obtained from evaluations from all Faculty of Arts & Science programs, with a trend upwards.

A breakdown of the data by level of study shows that our 400-level courses generally have outperformed the faculty average, whereas 300-level courses have been slightly lower. This underscores the fact that our original 300-level courses require some improvement.

We attribute the lower evaluation scores in the 300-level courses to two factors:

1. the two large lecture-style courses offered to students outside of the Pathobiology Specialist program in the third year (LMP301H1 and LMP363H1) dilute the responses from our departmental students; and
2. 300-level courses lacked cohesion and structure as revealed through the students' comments at our Town Hall. Our newly approved curriculum has been designed to address the issues in our 300-level courses. As such, three new 300-level courses are integrated with our 400-level courses to introduce the fundamental principles of pathobiology, and by having no more than three instructors per course, cohesiveness will be significantly improved.



Comparison of evaluation results 2019-2020

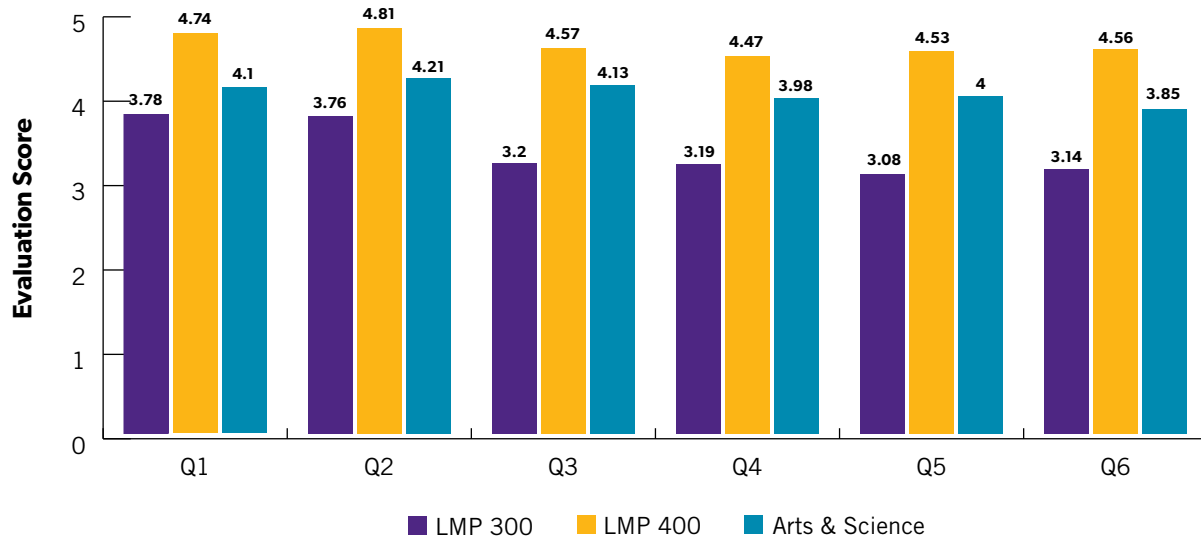

Student satisfaction: NSSE

The National Survey of Student Engagement (NSSE) provides educators with an estimate of how undergraduates spend their time and what they gain from attending university.

Based on the NSSE database, our program is unique, with only six other students identified as being enrolled in Pathology / Experimental Pathology in the U15 comparator group (the [top 15 research universities in Canada](#)). Due to the small group size, the statistics obtained for the U15 Pathology / Experimental Pathology group may not capture a representative picture of the program for comparative purposes. Thus, the comparisons below will be drawn in relation to the all-disciplines data from the University of Toronto, Ontario, and the U15 group.

High-impact practices

The Pathobiology Specialist program has excelled in providing learners with High-Impact Practices (HIP). HIPs are defined as tasks that demand considerable time and effort, facilitate learning outside the classroom, require meaningful interactions with faculty and students, encourage collaboration with diverse others and provide frequent and substantive feedback.

High Impact Practices 2017	U of T (LMP)	U of T (all disciplines)	U15 (all disciplines)	Ontario (all disciplines)
One HIP	6.3%	27.3%	27.7%	28.4%
Two or more HIPs	93.8%	49.4%	54.8%	53.2%
Total who participated in at least one HIP	100%	76.7%	82.5%	81.5%

Student satisfaction

The data on student satisfaction indicate that we rate higher than all University of Toronto, Ontario and U15 programs on:

- 4: Quantitative reasoning
- 6: Discussions with diverse others
- 7: Student-faculty interaction

This is consistent with the strengths of the Pathobiology Specialist program, where we have small class sizes that promote vigorous group discussion.

Engagement indicator (0-60 scale)	NSSE year	U of T (LMP)	U of T (all disciplines)	U15 (all disciplines)	Ontario (all disciplines)
Academic challenge					
1. Higher-Order Learning	2014	35.9	38.0	36.4	38.0
	2017	35.0	37.3	36.3	37.2
2. Reflective and Integrative Learning	2014	30.4	35.4	35.2	36.6
	2017	33.9	35.7	35.4	36.4
3. Learning Strategies	2014	36.7	35.7	35.1	35.2
	2017	35.0	34.5	34.5	34.1
4. Quantitative Reasoning	2014	34.0	25.5	26.7	27.0
	2017	33.8	27.0	27.2	27.6
Learning with peers					
5. Collaborative Learning	2014	27.1	29.2	32.8	33.3
	2017	29.1	30.9	33.7	33.9
6. Discussions with Diverse Others	2014	52.5	42.3	40.3	41.7
	2017	48.1	41.0	39.3	40.4
Experiences with faculty					
7. Student-Faculty Interaction	2014	20.9	17.5	17.2	18.9
	2017	25.3	18.0	17.4	18.9
8. Effective Teaching Practices	2014	27.6	35.3	34.9	35.8
	2017	24.3	34.3	34.4	34.5
Campus environment (not program or course specific)					
9. Quality of Interactions	2014	39.5	37.2	39.0	39.6
	2017	34.0	36.2	38.4	38.3
10. Supportive Environment	2014	24.3	26.2	27.8	28.9
	2017	25.8	24.9	26.9	27.6

Each Engagement Indicator (EI) is a summary measure based on sets of NSSE questions examining key dimensions of students' engagement. The ten indicators are organized within four themes. Each EI groups the responses from the questions in its respective category, rescales them from 0 to 60 (e.g., Never=0, Sometimes=20; Often=40; Very often=60) and averages the responses. A score of 0 means every student chose the lowest response option, 60 means every student chose the highest response.



How we will improve student satisfaction

Our new curriculum has been designed to address some of the weaknesses identified in the NSSE survey. We believe the new program will address the NSSE areas where our program scored lower than the University of Toronto, Ontario, and U15 all discipline comparators.

For example:

- Our 300-level courses are designed with three blocks, each taught by one instructor. This allows the course to be taught with more structure and cohesiveness, thus providing a more ‘Supportive Environment’, and improving ‘Learning Strategies’ and ‘Effective Teaching Practices’.
- 300-level module topics were designed to introduce fundamental concepts for our 400-level advanced topic courses, thus improving ‘Reflective and Integrative Learning’.
- All new courses are small (35 students or under), thus allowing for more ‘Collaborative Learning’ and ‘Quality of Interactions’.
- Changes to our 400-level courses enable us to focus on advanced topics of disease to improve ‘Higher-order Learning’ and ‘Reflective and Integrative Learning’.

Graduation rates

The seven-year graduation rates are calculated based on the Ontario Ministry of Colleges & Universities methodology. The compiled data are categorized into broad disciplines/cohorts of students. The Pathobiology Specialist program would fit under the “Other Arts & Science” cohort, which is by far the largest cohort group at 7,153 students and has a graduation rate of 75.3%. However, the data presented should be carefully used when drawing conclusions about the Pathobiology Specialist program, given the broad stratifications used in Ministry data.

To provide another perspective on the graduation rate, we can also calculate a rate using the program enrollment numbers and the number of students at graduation three years later. This provides us with a pseudo ‘graduation rate’ that may reflect our program’s performance better. However, this statistic still has its flaws and may not capture all the nuances. For example, students may transfer into another program after 2nd year. Our ‘graduation rate’ statistic would not consider this and would count it as someone who did not graduate. Thus, the numbers that we present likely underestimate our actual graduation rate.

Overall, our calculated graduation rate is 78.1% based on data averaged from the past five years. It is noteworthy that our graduation rates have improved for the class of 2019 and 2020 (88.4% and 86.7%, respectively). This is substantially higher than the University of Toronto’s and Ontario universities’ graduation rates.

Figure 3. Calculated graduation rate for the Pathobiology Specialist program

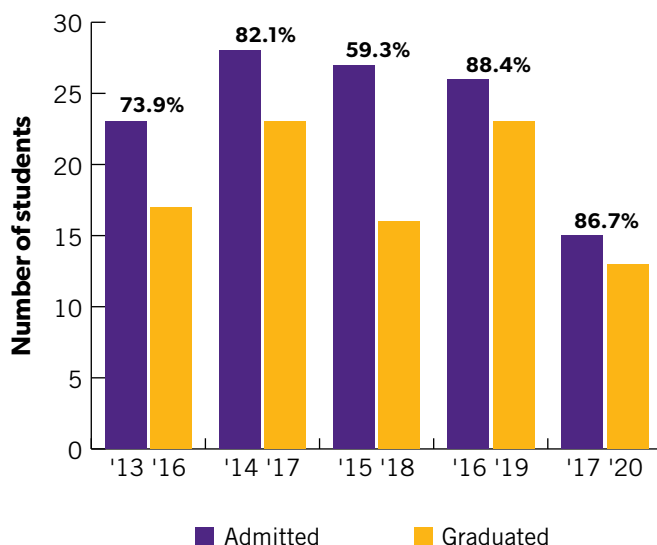

3 Undergraduate A&S Specialist Program in Pathobiology

Program outcomes

Employment rates are not appropriate for the Pathobiology Specialist program as most of our students enter advanced degree programs (MSc, PhD, MD, Pharm D etc.). The best indicator of our program outcome is the students' location in the years following graduation.

The U of T Alumni office has 153 Pathobiology Specialist students on record. Of these 153, we have collected outcomes for 90 students (58.8%) graduating between 2013 and 2020, inclusive.

Next steps for our graduates

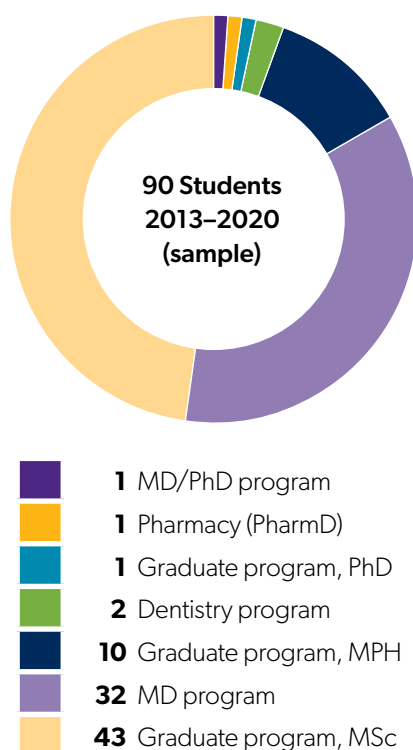

Quality enhancements

As mentioned, following an extensive consultation process involving students and faculty across the department and university in 2019-2020, a series of recommendations provided the basis for a major curriculum modification process led by Drs. Mekhail and Lee. The major modifications were approved in March 2021 and we will offer the new curriculum to students entering the program in the fall of 2021.

Consultation within LMP



Consultations with Dr. Douglas Templeton, former coordinator and co-founder of the program (April 2019): discussed curriculum weaknesses/gaps and potential course additions.

- **Outcome:** The program would benefit from the inclusion/addition of new course options, including STA288H1: Statistics and Scientific Inquiry in the Life Sciences (highly relevant to the life sciences) and ANA300Y1: Human Anatomy and Histology (introducing students to anatomical pathobiology). The program would also greatly benefit from introducing a second-year course to start engaging our LMP students before the third year while providing them with an early foundation in pathobiology.

LMP Undergraduate Town Hall (October 30, 2019): met with former and current Pathobiology Specialist students to identify weaknesses/gaps in our courses/program and discussed potential improvements.

- **Outcome:** The addition of ANA300Y1 and STA288H1 as course options would provide our students with a stronger foundation that better prepares them for our fourth-year lecture-based and research project courses. The students also strongly encouraged the addition of a second-year LMP course that better prepares them for the materials covered in the third-year LMP courses.

LMP Undergraduate Curriculum Working Group (Summer and Fall of 2020): a seven-member group which met formally three times and informally over a dozen times to review/analyze the existing curriculum while considering all comments from Dr. Templeton and our students at the LMP Undergraduate Town Hall. The working group strongly recommended reorganizing the overall curriculum to ensure a gradual introduction of knowledge through vertically integrated courses across the academic years.



- **Outcome:** After careful and detailed consideration of all aspects of learning goals and outcomes, the group designed a new curriculum. This new curriculum emerged from the reorganization/redesign of courses in the third and fourth years and introducing a new second-year LMP course.

LMP Undergraduate Curriculum Working Group membership:

- Dr. Karim Mekhail, Committee Co-Chair, Co-Associate Chair Life Science Education
- Dr. Jeffrey Lee, Committee Co-Chair, Co-Associate Chair Life Science Education
- Dr. Stephen Girardin, Professor and Vice-Chair Research
- Dr. Michelle Bendeck, Professor and Former Director of Research
- Dr. Jeremy Mogridge, Associate Professor and Graduate Coordinator
- Dr. Scott Yuzwa, Assistant Professor
- Christina Ji, recent graduate (2019) of our Pathobiology Specialist program

Consultations with senior LMP faculty with curriculum design experience: The draft curriculum was presented to the following senior faculty in our department:

- Dr. Rita Kandel, Chair (October 14, 2020)
- Dr. Doug Templeton, former Undergraduate Coordinator and Co-founder of the Pathobiology Specialist (October 20, 2020)
- Dr. Avrum Gotlieb, Co-Founder of the Pathobiology Specialist, and Founding Chair of our Department (October 20, 2020)
- **Outcome:** All were laudatory, and no issues were identified.

Broad consultation with LMP faculty (October 23, 2020): The draft curriculum was presented in detail to our faculty members during a departmental faculty meeting.

- **Outcome:** No issues were identified.

Consultation with other departments and units from the University of Toronto

Consultation with departments offering new course options (October 22–23, 2020): Consulted with the departments of Statistics (Dr. Bethany White) and Anatomy (Dr. Cindy Morshead) regarding the addition of new course options.

- **Outcome:** Agreement to add STA288H1 and ANA300Y1 as additional course options within the Pathobiology Specialist.

Consultation with the LMP Student Union (LMPSU; November 9, 2020): The curriculum plan was presented to LMPSU co-presidents (Karen Mao and Ziqi Liu; fourth-year students in the Pathobiology Specialist program) and their LMPSU executive team.

- **Outcome:** The students were enthusiastic and looked forward to the changes. They especially welcomed the addition of a second-year LMP course, third-year research course, and STA288 and ANA300Y1 as new course options. In addition, we kept BIO220H1: From Genomes to Ecosystems in a Changing World as an option, moved PSL301H1: Human Physiology II back to the second year, allowing students to pick more than one option to include the research course LMP305Y1.

Consultation with other departments: We circulated the New Course Development forms to other departments within and outside Temerty Medicine (Molecular Genetics; Immunology; Biochemistry; Anatomy; Physiology; Pharmacology; Nutritional Sciences; Cell & Systems Biology) to ensure that we avoided course overlaps and instead promote synergy between courses.

- **Outcome:** As many of our proposed changes involved moving existing courses to different years, there are no overlaps. For new course proposals, a couple of minor concerns were fully resolved by conducting minor revisions to the proposed courses.

Formal Consultation with Temerty Medicine Undergraduate Coordinators Committee: The new course proposal and major modifications were formally presented to the Temerty Medicine Undergraduate Coordinators Committee on November 20 and 27, 2020. This committee is chaired by Vice Dean Sal Spadafora and includes the Associate Chairs from Molecular Genetics, Immunology, Biochemistry, Anatomy, Physiology, Pharmacology, Nutritional Sciences, and LMP.

- **Outcome:** Only two minor concerns related to perceived overlap were identified and fully resolved through minor revisions to two proposed courses (LMP310H1: Foundations of Pathobiology and LMP430H1: Metabolic disorders). All departments were now fully supportive of the major modifications proposed.

Specific major modifications

Ultimately, these consultation processes led to Drs Karim Mekhail and Jeffrey Lee submitting a major curriculum modification to the Faculty of Arts & Science (Figure 1: Curriculum Design on [page 53](#)) which was approved in March 2021. The specific major modifications resulted in the modernization of the program and improved cohesion, integration, and personalization while expanding experiential learning.

Aaron Dou



Juliette Lee

Amanda Mao



Student Awards

Departmental awards

Our department offers two major awards for our Pathobiology Specialist students:

Third Year Pathobiology Award

The student with the top aggregate mark in our required “LMP340H1 and LMP350H1: Introduction to Pathobiology I and II” and “LMP365H1 Neoplasia” courses are given a certificate and cash award.

- 2013: Roland Shuzhengrong Xu
- 2014: Claudia Dziegielewski
- 2015: Charles Lee
- 2016: Khalid Fahoum
- 2017: Yuki Sze Long Leung
- 2018: Chen Fan (Christina) Ji
- 2019: Elizabeth Yan
- 2020: Juliette Lee and Amanda Mao
- **2021: Aaron Dou**

Gornall Prize

The student graduating from the program with the highest cumulative GPA over their four years is given the Gornall Prize, funded by an endowment from the late Allan Gornall, who was Chair of Clinical Biochemistry at the University of Toronto in the 1960s/1970s. It consists of a plaque and a cash award. Recent winners are:

- 2013: Florence Chan and Pei Jun Zhao
- 2014: David Kleinman and Roland Shuzhengrong Xu
- 2015: Maya Deeb
- 2016: Charles Lee and Amber Cintosun
- 2017: Yizhuo Kelly Gao
- 2018: Yuki Sze Long Leung
- 2019: Frederick Tianlun Zhang and Zixuan Xiao
- 2020: Michael Lee
- **2021: Juliette Lee and Amanda Mao**



Faculty- and university-level awards

Our Pathobiology Specialist students are highly competitive for several prestigious faculty- and university-level awards.

GLSE Undergraduate Student Leadership Award

The purpose of this award is to provide opportunities for our undergraduate students in the Temerty Faculty of Medicine, Arts and Science Programs to be recognized for their leadership and scholarship. The Graduate and Life Sciences Education Office in Temerty Medicine awards up to three annual Undergraduate Student Leadership

Awards in Life Sciences for their outstanding contributions to academic and student life at U of T. This is the most prestigious undergraduate leadership award available to our students. Impressively, our Pathobiology Specialist students have had at least one winner in each of the past eight years:

- 2013–2014: Anatasia Bosc
- 2014–2015: Maya Deeb and Alina Zelinka
- 2015–2016: Charles Lee and Amber Cintosun
- 2016–2017: Sudarshan Bala and Khalid Fahoum
- 2017–2018: Linwen Huang
- 2018–2019: Abdullah Malik and Chen Fan (Christina) Ji
- 2019–2020: Michael Lee and Laura Tang
- 2020–2021: Karen Mao

LMP undergraduate student recognized in GLSE awards



Karen Mao, Co-President of the LMP Student Union (LMPSU) 2019–2020
Co-President of the Medical Sciences Student Union, received the GLSE Undergraduate Leadership Award 2021.

[Read more about Karen](#)

University of Toronto Cressy/ Student Leadership Award

The University of Toronto Student Leadership Award recognizes outstanding student leadership, service, and commitment to the university. This tradition began with the Gordon Cressy Student Leadership Award, established in 1994 in honor of Mr. Gordon Cressy, former Vice-President, Development and University Relations. During the award's 25-year history, it celebrated the exemplary contributions of more than 4,000 students whose commitment and service had a lasting impact on their peers and the university. Recent winners from the Pathobiology Specialist program are:

- 2014: Anatasia Bosc; Benedict Darren
- 2019: Helen Yang
- **2020: Michael Lee**

Michael Lee



NSERC Undergraduate Student Research Awards (USRA)

USRAs are offered by the Natural Sciences and Engineering Research Council of Canada (NSERC) to encourage undergraduate students to develop their potential in research. The NSERC USRA provides funding for 16-weeks of research during the summer or academic year. Recent Pathobiology Specialist recipients are:

- 2013: Kristiana Xhima and Bryce Chen
- 2014: Bryce Chen
- 2015: Ashley Zhang
- 2020: No recipients due to COVID-19
- 2021: Young June Kim

Response to 2013 External Review

The reviewers praised our undergraduate program for its coherence, recruitment of top students, and well-structured curriculum and program delivery. The reviewers cited: *“The program recruits high caliber students, who are enthusiastic learners and receive a high level of education.”*

However, the review highlighted that the program was on a small scale and not meeting enrollment targets.

The new undergraduate coordinators, Dr. Jeffrey Lee and Dr. Karim Mekhail made it a top priority to strengthen student recruitment initiatives and improve enrollment for the Pathobiology Specialist program, so they:

- led a complete review of the program and modernized the curriculum to ensure an improved alignment with students’ needs.
- increased outreach and recruitment of first-year students by attending University of Toronto Fall Campus Days, A&S Program Exploration Days, and Medical Science Student Union Subject POST Seminar.
- partnered with the LMP Student Union in their recruitment activities to have current Pathobiology Specialist students act as program ambassadors.
- organized an LMP Pathobiology Specialist Reception to help recruit prospective students invited into the program.

	Prior to 2019	After 2019
Students joining the program	23	at least 33
Students overall	87 or less	93 in 2021
Minimum high school average	95.3%	95.3%
Percent grad average in first year	88%	88%

We remain selective, which allows us to maintain a vibrant student community and offer small class sizes. Providing small class sizes and high faculty-to-student ratios is a hallmark of the Pathobiology Specialist Program, allowing us to provide a high-quality education environment for learners.

Strategic plan

In the 2015-2020 LMP Strategic Plan, three important directions were identified to improve the undergraduate program:

1. Extend exposure of undergraduate life science students to laboratory medicine disciplines to reinforce the concepts of pathobiology and to career choices in the field.
2. Selectively engage clinical faculty in strengthening LMP’s presence in the life sciences curriculum (e.g. guest lecturer opportunities and lab visits).
3. Enhance the LMP summer student program to reflect unique departmental strengths and roles.

In the past five years, we have addressed all three areas suggested within the 2015-2020 Strategic Plan.

Reinforcing pathobiology concepts

Through broad consultation, the Pathobiology Specialist program curriculum has been modernized to provide learners with a stronger foundation of the concepts in pathobiology. The program’s overall goal, which consists of providing students with the fundamentals in understanding human health and disease processes, remains unchanged. The key modifications to the program now achieve the objectives of the Strategic Plan – more detail is in Curriculum Design.

Engaging clinical faculty

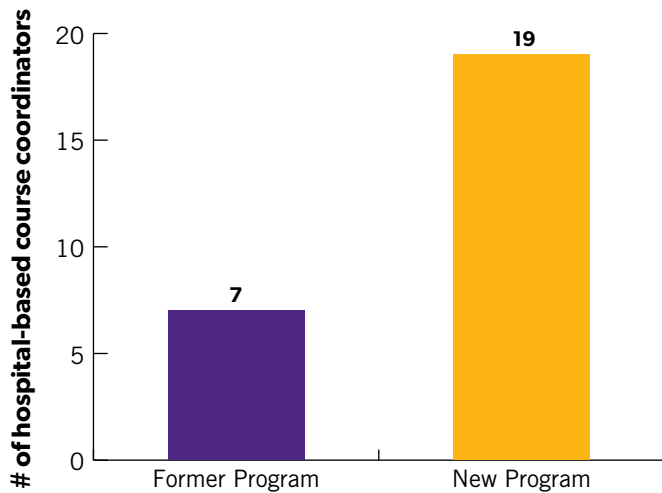

Engaging clinical faculty

Before curriculum changes, courses were primarily led by non-clinical tenured- or tenure-track faculty from the main campus; only seven course coordinators were hospital-based LMP faculty.

In the new Pathobiology Specialist program, each course is now structured into three blocks, with a faculty member responsible for teaching one month of lectures. This new model allows us to increase course coordinator roles to our hospital-based faculty while maintaining cohesiveness and continuity in teaching.

Once all new courses are offered, we will have 19 faculty from our affiliated hospitals as course coordinators. We believe this significantly strengthens the presence of our LMP clinical faculty in the life science curriculum.

Improvements to the summer program

In 2019, Dr. Jeffrey Lee became the LMP Summer Undergraduate Research Experience (SURE) program director. Based on student feedback, we modified the seminar series to better develop the critical skills students need to become a strong researcher and the soft skills they need for their future careers.

We designed a new set of seminars covering:

- good laboratory practice
- research ethics
- literature searches
- critiquing papers
- giving effective oral presentations
- how to make an effective poster.

The LMP SURE Research Day now dedicates a half-day to workshops and networking events aimed at developing students' scientific interests, understanding what graduate research is about, and career opportunities in Pathobiology.

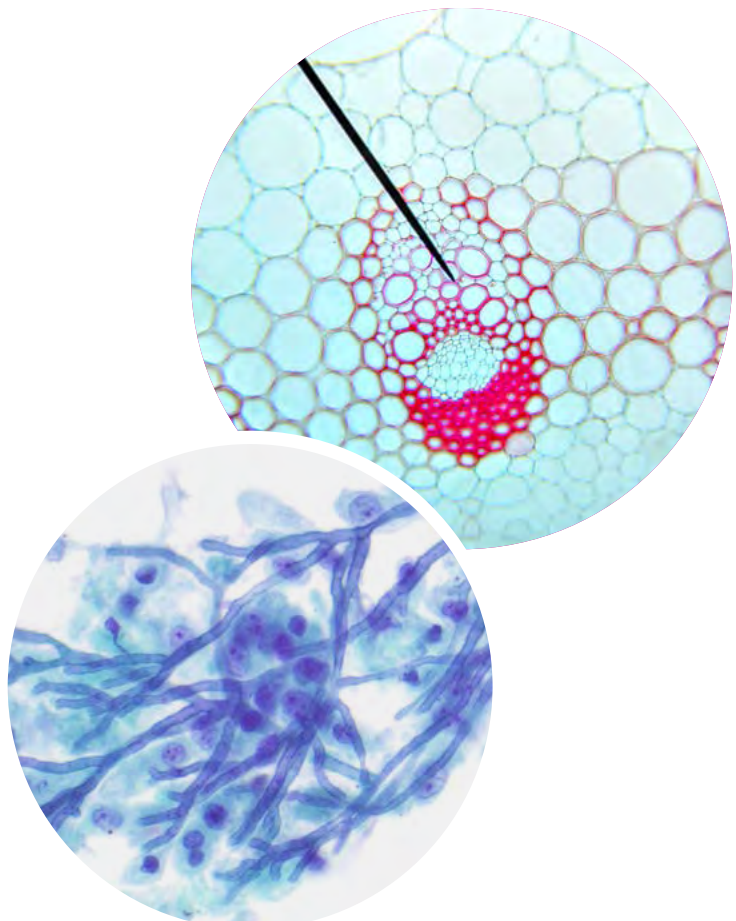



Clinical and Professional Education

MHSc in Translational Research

The Master of Health Science in Translational Research (Translational Research Program, TRP) is a two-year professional degree program that enables students to grow their domain expertise with a facilitated collaborative capstone project that emphasizes experiential learning and translational thinking.

An evolving field, our working definition of Translational Research is 'a field of investigation focused on understanding the practices and principles underlying the processes of turning knowledge, observations and discoveries into interventions that improve the health of individuals'. This definition speaks to both the activities of translation in health sciences, understood as the movement of discoveries, research and knowledge across domains for positive impact on human health, and the act of abstracting principles and best practices from translational activities as a form of knowledge production.



The program was originally launched in 2015 through the Institute of Medical Sciences (IMS) and was transferred to LMP in 2019 following an external review.

The TRP focuses on:

- **Breadth:** looking at the larger translational landscape
- **Deployment:** competencies around the implementation of projects and prototypes
- **Integration:** combining individual domain expertise with practical projects and case studies that emphasize experiential and integrated learning.

Our program’s components are designed to augment a student’s previous training with practical and conceptual breadth spanning translational practices from discovery science, clinical research and population-based practices to knowledge translation, development and mobilization, stressing:

- a person-centric approach (i.e. patient-, physician-, healthcare provider-oriented)
- collaboration
- peer learning: students learn from people, discussants, faculty and most of all, each other.

The TRP is a unique and developing program that represents LMP’s dedication to competency-based education. Through it, we are further understanding how to develop transferable and future looking competencies in our graduate students, and broadening our skills in pedagogy and experiential learning for multidisciplinary and interprofessional students.

Our dedication to learning from doing is a mechanism for the entire department and (by extension, faculty) to improve the student experience. Since its launch, the short-modular courses the TRP explored have become adopted across multiple departments and standardized at the faculty level. The variety and ability to adjust curriculum in modular courses introduced by the ‘LMP2390 Special Topics’ course helps provide students with more choice and relevant content driven by interests and evolving contexts.

The TRP represents a dedication to innovation: trying new things, evaluating their usefulness and success, and making continuous adjustments to courses, pedagogy and training that can benefit students and faculty across the department.

Learning outcomes

Our overall objective is to **challenge students to think differently** so that they may champion change in their communities and contexts to **advance medicine, health, and care.**

How we encourage students to think differently

1. Learn to identify person-centric innovation and ingenuity gaps
2. Scope problems
3. Verify assumptions
4. Test and iterate on student-driven real-world projects to translate knowledge and discoveries into action.

We do this using a scaffolding approach to problem-based learning where we add complexity iteratively. Students begin with case-studies that introduce concepts and principles and through reflection, self-assessment, and co-creation acquire and practice skills and competencies that empower them to:

- Communicate more clearly and persuasively
- Lead and collaborate effectively
- Recognize opportunities
- Learn resilience from failure
- Question assumptions and explore new points of view
- Focus and assess people’s needs
- Navigate complexity to mitigate risk

4 MHS in translational research

We expect our students to develop skills in the following degree level competencies:

Adaptability

- Demonstrates alternative ways to achieve goals
- Demonstrates resourcefulness and alternative ways of action
- Works independently or as a part of a team
- Navigates ambiguity and uncertainty

Creative problem solving

- Discovers, assesses, prioritizes situations to identify problems
- Recognizes, restructures and evaluates multiple dimensions of a problem

Critical thinking

- Applies the information from a variety of sources
- Locates, accesses, gathers, organizes, analyzes, and synthesizes information
- Seeks, evaluates and prioritizes different points of view

Effective communication

- Accesses, understands and conveys information
- Actively listens and asks questions to understand
- Effectively reads, writes, and presents skills

Initiative

- Embraces opportunities
- Proposes, shares, tests and implements ideas into concepts
- Sets goals and priorities
- Shows resourcefulness and effort

Leadership

- Works and understands the dynamics of a team
- Provides direction
- Enables others to perform
- Implements and monitors the plan of action
- Plans and manages time and resources

Continuous learning

- Assesses personal strengths and areas for development
- Demonstrates a willingness to grow
- Identifies and accesses learning opportunities and sources

Conflict management and resolution

- Develops resolution strategies
- Identifies conflict
- Implements and monitors the plan of action

Risk management

- Establishes, implements and monitors progress and contingencies
- Moderates uncertainty

Integrity

- Demonstrates honesty, integrity and personal & professional ethics
- Takes personal accountability and social responsibility for your actions

Relationship management

- Establishes and maintains professional networks
- Shows respect for others and alternative points of view

Team Collaboration

- Accepts and provides feedback
- Shares information, work and expertise
- Contributes actively and effectively

4 MHS in translational research

Course	Course Name	Credit	Schedule
LMP 2300Y	Foundations in Translational Research	1.0 FCE	Year 1 – Fall & Winter
LMP 2310Y	Modules in Translational Research	2.0 FCE	Year 1 & 2 – This is a continuous module course that runs throughout the two years until you complete 8 modules.
LMP 2322H	Information, Media, and Communication Literacy for the Sciences	0.5 FCE	Year 1 – Fall
LMP 2302H	Overview of Methods in Practices and Contexts	0.5 FCE	Year 1 – Winter
LMP 2301Y	Projects in Translational Research (Capstone Prep)	1.0 FCE	Year 1 – Fall and Winter
LMP 2330Y	Capstone Project in Translational Research	2.0 FCE	Year 2 – Fall and Winter
Electives	1.0 FCE of Electives	1.0 FCE	Year 2 – Usually
Total		8.0 FCE	

Curriculum design

The TRP's mission of challenging learners to think differently through experiential learning and reflection build on notions of andragogy (Knowles, 2012). Our program is designed around an integrated curriculum linking curricular and co-curricular activities that rely on self-directed learning and facilitative mentorship. The integrated curriculum spans all our course offerings and is designed using a scaffolding approach to progressively move learners towards greater understanding and self-directed learning.

This can present an extraordinary challenge of ensuring all instructors and seminars are in sync and building upon each other. To ensure complementarity and cohesion between the courses, we have attempted to stabilize the instructor pool (see [page 89](#)).

The delivery methods we use are intended to establish a culture of:

- direct observation and engagement
- reflection and abstraction of those experiences
- their integration with previous knowledge, and
- their testing and evaluation in real-world contexts.

To ensure the program meets a spectrum of learning objectives for a multidisciplinary student body with varied professional and life experience, we employ a wide range of teaching strategies. These include:

- seminars
- presentations
- pitches
- papers
- peer-feedback
- group case studies
- individual assignments
- formal and informal written and oral communication exercises
- self-directed community-based needs analyses



Supported by:

- partner projects
- student-led initiatives
- co-curricular activities.

Through continuous dialogue with students, we have iteratively refined and improved the program.

The various activities are integrated into our curriculum map and linked to learning objectives. They are designed with a scaffolding approach but give enough flexibility and student-driven exploration to allow students to work towards learning objectives like leadership, managing risk, networking, collaborating with people, demonstrating an openness to new ideas and a willingness to listen to the opinions of others. These program structures are also designed to allow students to learn from each other, and to share their individual and group insights and experiences with the rest of their cohort.

We have five required core courses:

- LMP2301Y: Foundations in Translational Research
- LMP2320H: Overview of Methods in Practices & Contexts
- LMP2322H: Rhetoric of Science
- LMP2301Y: Projects in Translational Research
- LMP2330Y: Capstone Project in Translational Research

As part of the administrative move to LMP and curriculum review process, a major modification was passed to restructure the program in accordance with new Faculty level practices. A sixth core course (2.0 FCEs) that had been composed of a series of modules was eliminated and replaced by a requirement for eight quarter-courses (total of 2.0 FCE). We developed a series of quarter courses (0.25 FCE) based on the former modules, as well as several new course topics requested by students.

The TRP modular courses include:

- LMP2340: Project Management
- LMP2341: Project Management II
- LMP2342: Intellectual Property Fundamentals
- LMP2343: Applied Intellectual Property
- LMP2344: Translational Thinking
- LMP2345: Procurement, Privacy, and Regulatory Affairs
- LMP2346: Grant Writing
- LMP2347: Economics of Healthcare
- LMP2348: Knowledge Translation & the Community
- LMP2349: SWARM

- LMP2350: Professionalism
- LMP2351: Leadership and Team Management
- LMP2352: Intrapreneurship, Entrepreneurship and Business Model Design
- LMP2353: Introduction to AI in Healthcare
- LMP2354: Hacking Networking
- LMP2355: Business Thinking (new in 2021 Winter term)
- LMP2390: Special Topics (new in 2021 Winter term)

A recent minor modification to the program allows students to sign up for and take equivalent modular courses offered by other departments. This change increased the potential for interdisciplinary interaction and the range of programming accessible to our students. To encourage exchange, we reserve spaces for students external to our program in our modules. For example, we signed a Memorandum of Understanding (MOU) with the Institute of Medical Science in 2020 to ensure their students have designated space in TRP modular courses.

You can see full details in Appendix 1.3.1: TRP Curriculum Guide.

Recommended program pathway

Term 1	Term 2	Term 3	Term 4	Term 5
LMP2300 Foundations in TR				
LMP2301 Projects in TR				
LMP2310 Modules in TR				
LMP2322				
	LMP2320			
		TR Thinking		
			LMP2330: Capstone Project	
			Elective 1	Elective 2

An innovative curriculum

The main innovation behind the TRP is the approach to establish it as a responsive platform focused on both individual development and on collaborative problem-solving through person-centric design processes. We encapsulated this in the Toronto Translational Framework (TTF) that we developed to guide our students through the innovation process within health science contexts.

Although a number of translational medicine and translational research programs have started in recent years, none have yet employed the kind of modular capstone-based structure we have developed in the TRP. Although this type of structure is not uncommon in Engineering and Design focused programs, most Health Science ‘translation’ focused programs employ a more traditional research approach with opportunities for interdisciplinary interaction (e.g., U of T, Queen’s University).

Despite the continuous and ongoing changes since the beginning of the program, by the time the TRP underwent an External Review in 2018, the overall curriculum map had stabilized. Although there has been some variation in the delivery and integration of the curriculum, the curriculum map has remained largely unchanged.

Toronto Translational Framework™ (TTF)

While many other translational programs have put together research and clinical activities and faculties, or have incorporated ‘translational’ topics in their teaching (e.g. professional development, collaboration, or intellectual property materials), none have gone to the length of structuring the curriculum around a framework for approaching translation as we have.

The TTF builds upon design thinking, experiential learning, human-centered Participatory design and elements of design control (FDA) and engineering practices. The strength of the approach is the focus on, and consideration of, health and medicine as the contextual domain of inquiry and application. The TTF provides students from various disciplines with a common set of tools, lexicons and strategies for systematically approaching the translation of knowledge into innovation.

In addition to the intellectual framework we have developed, there are several other key features to the Program that make its delivery innovative. Examples include the use of class reflection surveys, the focus on reflection, and the use of multiple delivery modes to achieve a variety of learning objectives, and the capstone project as a vehicle for experiential learning.

Toronto Translational Framework™ (TTF)

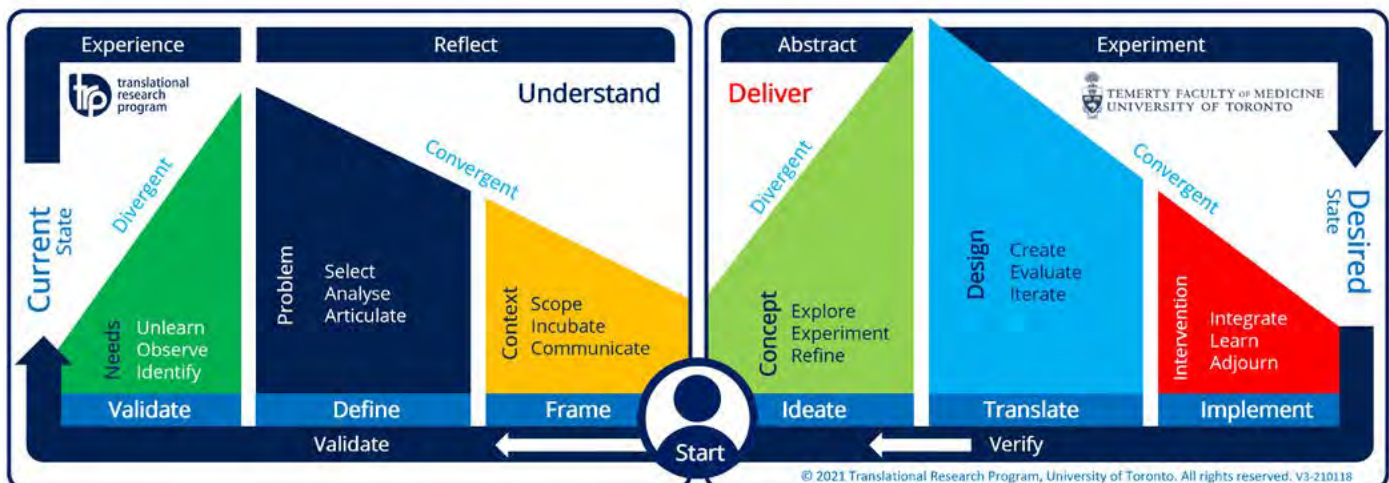



Personalised learning

Individual Development Plans (IDPs)

Our approaches for program delivery are supplemented by personalized goal setting through Individual Development Plans (IDPs) and reflection. Each student meets individually with their TRP advisor every term to set and review personal goals and accomplishments. Introduced with the 2016 cohort, the IDP is an important aspect of the TRP's personalized learning experience (see Appendix 1.4.1: Core Pedagogy & Teaching Methods).

This process allows students self-evaluation of actions and activities that they self-initiate under the supervision of a program faculty advisor.

It took several cycles of practice and training, and a broader faculty adoption of IDPs, to embed IDP engagement at the TRP. Although voluntary, almost every student now sees their IDP advisor at least once every term and some students make standing appointments as often as every two weeks.

Flexible modules

The original intent of the module course structure was to ensure the program could deliver new and innovative content without the overwhelming administrative overhead needed for minor program modifications. One concern around formalizing modules at the Faculty level was this ability to innovate. To address this, we championed a new type of course in Temerty Medicine.

'LMP2390H: Special Topics' is a new type of modular course that allows us to test new content (up to two times) with department level review before initiating the minor program modification governance review required to pass a new course.

This course type was tested in the Winter term of 2021 to deliver a module called: Innovation Bootcamp (see Appendix 1.4.2: LMP2390 Documentation).

Elective coursework

Our program also incorporates room for flexibility and individual interests through elective coursework (1.0 FCE) outside the program, department and even institution. Students have taken courses related to their capstone projects in health policy, knowledge media design, biostatistics, engineering and computer science, to name a few.

Diverse learning opportunities

To add to the intellectual rigor of the program, we have institutionalized multiple core elements.

The community in which our students learn is a vital part of the curriculum, as outlined below. The depth and variety of people that have been involved with the TRP is not only a testament to the interesting projects that our students develop, but also to the strength and potential of our educational approach.

We are also engaged with Temerty Medicine and five other departments (Surgery, Medicine, Psychiatry, Pediatrics and Medical Imaging) to establish a multi-lateral international network of local translational hubs that would act as centres for local, regional, and global translational research, education and support. This further expands TRP student opportunities and interactions.

Discussants

Discussants are integrated into many classes and join seminars to discuss issues and solve problems with students. They come from a variety of backgrounds; for example, prominent industry vice presidents, high-ranking government officials, powerful patient advocates, and organizations, including research, industry, government, and hospitals.

We leverage the large community of researchers and professionals throughout the Toronto Academic Health Science Network (TAHSN). This also provides students with networking opportunities and a wide range of perspectives.

In 'LMP2300Y Foundations in Translational Research' alone, students are introduced to over 35 discussants. See Appendix 1.4.3: Discussants, Mentors and Project Advisors for a list of our TRP affiliated community.

TR Talks

TR Talks is a panel discussion series associated with 'LMP2300: Foundations in TR', where panelists discuss topics linked to those discussed during the seminars. Moderated by a variety of people (from vice presidents of the University, like Vivek Goel or Christine Allen, to prominent researchers and medical educators like Norman Rosenblum, former Associate Dean of Medical Education). These discussions provide students with exposure to a variety of opinions, insights, networking, and community building opportunities. The TR Talks are supported by the

4 MHS in translational research

U of T Connaught Global fund and delivered in partnership with the Health Innovation Hub and Medical Innovation Toronto - both represent key relationships that allow TRP access to a larger network of experts and resources for our students.

2,000+
attended TR
Talks 2020/2021
(including current and
prospective students,
and alumni)

During the COVID-19 pandemic in 2020, TR Talks became online discussions. Although this reduced opportunities for individual interaction and networking, we did see a significant increase in participation.



Case-study Principal Investigators (LMP2300)

Case-studies give students opportunities to work with a variety of people on real-world problems. During the first two terms, students are involved in three case-studies, each becoming more complex and autonomous.

The third iteration pairs student groups with mentors, researchers, professionals, government or industry partners to focus on a preselected translational problem. The partners provide students with actual real-world problems they have or are facing and serve as the “Case-Study Principal Investigators” who direct the student research into their problem or project.

Examples of PI-led case-studies

Deploying, regulating, funding, and implementing freeze-dried vaccines in the developing-world

Exploring novel medical device technologies for industry partners

Working with Health Quality Ontario to assess implementation of new clinical interventions

Developing strategies for distribution of post-partum interventions to rural communities

Developing a global strategy for coordinating biobanking of cancer tissue samples

Partner projects

To provide students with additional opportunities to experience real-world problems, within ‘LMP 2301Y Projects in TR’, students act as consulting translators for partner projects. This real-world problem closely mirrors students’ own needs for finding ways to discover innovation gaps and network with a range of clinical and industry professionals.

Our partner collaborations in the core projects class was accepted as an exemplar for the annual University of Toronto Teaching and Learning Symposium.

Our Teaching Team presented “A Tale of two Hospitals” outlining the lessons learned about community integrated teaching and learning.



These exploratory interactions have included:

- Work with St. Joseph's Hospital executives, doctors, nurses, and patient advocates to validate hospital strategic priorities and develop projects within priority areas.
- Work with clinical researchers at Sunnybrook Health Sciences Centre to develop strategies for dealing with postoperative delirium.
- Development of a tool at Sunnybrook Health Sciences Centre for patient decision-making around facial reconstructive plastic surgery.
- Work with the not-for-profit Saint Elizabeth Health Care on researching the effective deployment of community-based at-home chemotherapy.

We have built partnerships with other U of T departments; hospitals such as St. Joseph's Hospital, Sunnybrook Health Sciences Centre and the UHN; industry like Invivo, Autodesk and Jlabs; and groups like Medical Innovations Toronto (a Eureka Institute global Translational Medicine partner hub), the Health Innovation Hub, AgeWell and PRiME.

Mentors and advisors

Mentors-in-residence are a pool of loosely affiliated faculty who help students develop their capstone project ideas during the summer. Students also have access to a wide range of domain experts who provide deep and broad intellectual support as Capstone Committee Advisors. To date, advisors have ranged from CEOs of hospitals and Department Chairs to Institute Directors and prominent researchers.

More recently, program alumni have returned to help facilitate case studies across several courses, and we have developed industry and community partners who help students explore real-world projects in industry, government, and hospital settings.

Capstone project and Advisory Committees

The Capstone is where students can define, scope, and execute a project that focuses on translational research. The Capstone Project course (LMP2330Y) is taken in the second year of study for both fall and winter sessions.

The capstone:

- is a student led initiative, approved by the program
- can be either individual or collaborative
- must provide an opportunity for students to demonstrate that they have acquired the program's core competencies.
- is assigned a TRP supervisor – ideally a core faculty member or long-standing instructor and has a Committee of Advisors.
- is a pass-fail required course in which competencies displayed by the student are assessed by a committee composed of the course director, the TRP supervisor and committee members.

Students are required to demonstrate an ability to write a Research Ethics Board (REB) application, create a poster for presentation at the LMP Annual Research Conference and present and defend their work.

Structuring the capstone project is a key innovation of the program: the combination of structural supervision and domain-specific support is essential. This structure has been fine-tuned over time to ensure inter-supervisor consistency. There are comprehensive guidelines for expectations of and deliverables by the learner, and clear expectations for Advisory Committee members. Additionally, there is significant student pre-capstone preparation.

The TRP capstone project process is comprised of eight components:

1. **Get started:** establish the capstone team.
2. **Identify a need:** this must be based on direct engagement with people or patients using appropriate methodologies.
3. **Proposal:** state the need as a problem and articulate a plan to address the problem.
4. **Proposal Assessment:** a formal review of the proposed plan and deliverables.
5. **Project and reflection:** execute the plan and reflect on the process.
6. **Review:** group critiques, milestone reports and committee meetings.
7. **Presentation:** final project team presentation and individual oral assessment.
8. **Final Reflection:** written individual assessment of learning and knowledge production.

4 MHSc in translational research

The role of committee advisor for the capstone differs slightly from that of a thesis-based committee advisory role so educating faculty members (in particular) is key to ensure expectations and commitments are properly managed. To do this, we have developed an Advisor Guide with clearly stated minimum expectations; these are restated in a commitment contract that advisors sign before starting their role. Currently, clearer reporting and assessment tools provided to advisors now ensure confidential and frequent feedback about student performance. In addition, interaction between the TRP supervisor and the advisory committee has now been increased by ensuring supervisors attend committee meetings.

See Appendix 1.4.4 for a list of Previous Capstone Titles and abstracts.

Peer Learning in the Capstone Project

Peer Learning remains both a weakness and an opportunity and we have yet to find an optimal delivery format. When the program was smaller and face-to-face, students were asked to attend one class every month during which they would provide a 2–3-minute update on the state of their capstone. Once a term these updates would include the students from another cohort and TRP community members. These rapid updates were followed by a social activity, which allowed students from both cohorts to interact. The updates allowed students to provide insights, resources and support for other students and projects - to learn from and contribute to peer learning.

As class sizes grew, and the number of projects increased, students began to see these updates as unnecessary and unproductive. When the program switched to online delivery in March of 2020, these issues were exacerbated. Without a social activity following the updates and with the opportunity to interact during the presentations of others, the quality and frequency of the feedback dropped significantly, and students demonstrated greater resistance to participating in these rapid update sessions.

To address these concerns, we have experimented with a flipped classroom model for project updates. For example, we have tested online software like VoiceThread to allow students to post presentations for asynchronous review and peer comments in advance of seminars. Although the learning curve for the software and the culture of asynchronous feedback have been interesting challenges for implementation, this delivery format is showing promise.

Group work

Managing group work with interdisciplinary teams and students from a broad range of career stages and with different career motives has been a challenge for many programs. Although we have our share of challenges in this area, we have made significant strides in managing disparities that can arise in group work.

In addition to incorporating team building and negotiation elements within the curriculum, we have also added strategies like team charters, peer review, and an individual evaluation mechanism.

- **Team charters:** students are put into teams initially without much guidance or direction, then, over time as the group work becomes more complex, students are introduced to tools like a team charter to help structure team interactions, deal with conflict and move towards their capstone projects. Although the effective use of team charters has not been universally implemented across the program, where they have been used effectively, they have produced extraordinary results and we will further increase their use.
- **Self-reflections and peer reviews are part of all group work in the program.** This confidential information gathered at the end of each project allows the instructor to better understand the team dynamics and provides guidance to help assign individual contribution marks to group projects. These strategies result in a range of potential marks even within a group for any given assignment – meaning that an individual who is consistently failing to contribute has a much harder time remaining unnoticed. Because project contribution and team feedback are considered during an assessment, it is possible for one member of a group to do well on an assignment, while another may not.



Assessment of learning

Although the TRP includes several traditional forms of assessment, the demonstration of competencies, not time-based or content-based assessment measures, drive the learning in the program. This is in keeping with training in our clinical programs. Assessing the ability to innovate is not straight forward and we explore the challenges more on [page 89](#).

Various courses (e.g., LMP2300, 2301, 2320, 2322, etc.) incorporate pitch presentations, written assignments and papers, case-study presentations and reports, as well as peer-learning and assessment strategies. These assessment tools along with their marking rubrics are intended to promote a culture of continual feedback and improvement.

Added to the more standard assessment strategies are a range of individual reflections that stress abstraction and integration of knowledge. Students are encouraged in all classes to spend time reflecting on discussions, speakers, and content. In 'LMP2300 Foundations in TR' for example, students are given reflection topics and the discussions of the topics form the topic primers in the subsequent class (part of the post-class surveys).

The combination of feedback and reflection as strategies to encourage individual development also forms the basis of the Individual Development Plans (IDPs) (see [page 77](#)).

All feedback, reflection and assessment tools established during the first two semesters of the program are then employed to help students develop project proposals and teams during the third term. Although the proposals are reviewed and iteratively rewritten throughout the term, we have found that they continue to be updated and improved by the student teams as they reach milestones and face challenges in their capstone projects.

The capstone projects are themselves designed to serve as mechanisms of continual assessment and feedback. Students meet with TRP Capstone Supervisors every two weeks and their Project Advisory Committees at least once a month. Minutes and goals are documented from each encounter and form the basis for milestone reports and students' individual and group project reports.

Although the capstone project is a pass-fail course, the various forms of feedback, mentorship and self-reflection allow students to clearly demonstrate competencies, skills and achievements that are linked to the TRP learning objectives and the program's graduate-level expectations.

Journals and reflection

TRP students engage in multiple reflection exercises through the program to ensure that they are encouraged to critically approach material and discussions. They are provided with journals during their initial orientation and with a framework for how to document and reflect upon ideas and concepts related to their studies. These are central to their final individual reflections at the end of the program.

In addition to the journals, most courses incorporate some form of active analysis of the content and students are asked to consider what they have learned and how they could integrate these learnings into their professional practices.

Contribution and group work

We have removed all attendance or participation grades in favour of individual "contributions" as an assessment tool for student engagement. Students are told that attendance and participation in seminars are the baseline expectation in any learning activity and that the real measure of their efforts is assessed through their contributions to their own and peer learning.

Students are provided with examples of behaviours that are encouraged for learning contributions. These behaviours include suggesting readings, posting discussions, bringing new information to seminars, providing other students with feedback and support, etc. Students are asked to record their contributions to classes in their journals and at the end of every class, are given an opportunity to document and submit their individual contributions as the assessment mechanism for the contribution portion of their mark in each class.

A similar strategy for assessing student contribution is employed with group work. As mentioned, we have introduced tools such as team charters and anonymous peer contribution statements to assess their perception of both their own contributions and those of others in their team. Along with formal contribution statements on group assignments, these peer contribution statements are used as an assessment tool to ensure that grading is personalized.

Co-curricular activities

A significant part of the TRP student experience is the co-curricular activities we organize or support to provide students with opportunities to develop and practice soft skills such as networking and confidence building, which complement the formal curriculum. Many of our co-curricular activities are not only important for generating capstone collaborations and project ideas but are also important for discovering available resources and building communities for professional development opportunities.

We provide workshops, networking opportunities and various activities that supplement coursework; these are delivered by the TRP team in collaboration with other groups and partners and, increasingly, by TRP students and alumni.

Examples of co-curricular activities:

- lab tours
- networking events like the Pillars of Health, Ride to Conquer Cancer TRP Team (which raised over \$75,000)
- involvement in conferences (Realities in Medicine and Kids Brain Health Partnerships Day)
- student games night
- social activities.

Example: Pillars of Health event

Held every six months in the MaRS Building

Organized by students

120 – 250 attendees from a range of healthcare pillars (industry, community, and academic groups) interested and involved with health innovation.

During the COVID-19 pandemic we have tried to maintain and encourage co-curricular activities with our students by hosting online networking events and supporting a social committee.

The TRP students have also taken up the gauntlet, having initiated several significant co-curricular activities over the past year. These activities include:

- **Oximeter delivery program:** students have been delivering oximeters to UHN patients who were self-isolating during the COVID pandemic.
- **TRP Anti-Racism Committee (ARC):** students have formed ARC, surveyed the attitudes of their peers, proposed strategies for more integration of Equity, Diversity and Inclusion (EDI) content in the TRP classes and curriculum; and are working on an EDI pilot module for the program.
- **TTF App:** students have initiated the digitization of the Translational Framework. They have designed, developed, and prototyped a cross-platform app to help future students better engage with the TTF framework for translational projects.
- **TRP Fitness Group:** students received a grant to help develop online fitness activities that students can do together and have integrated stretching and exercises during classes to try to improve student health and wellness.
- **Patient Podcast:** students initiated and produced a patient-focused podcast series they have called the [IMPACT GAP](#).

Student recruitment and acceptance

Applications, offers and registrations

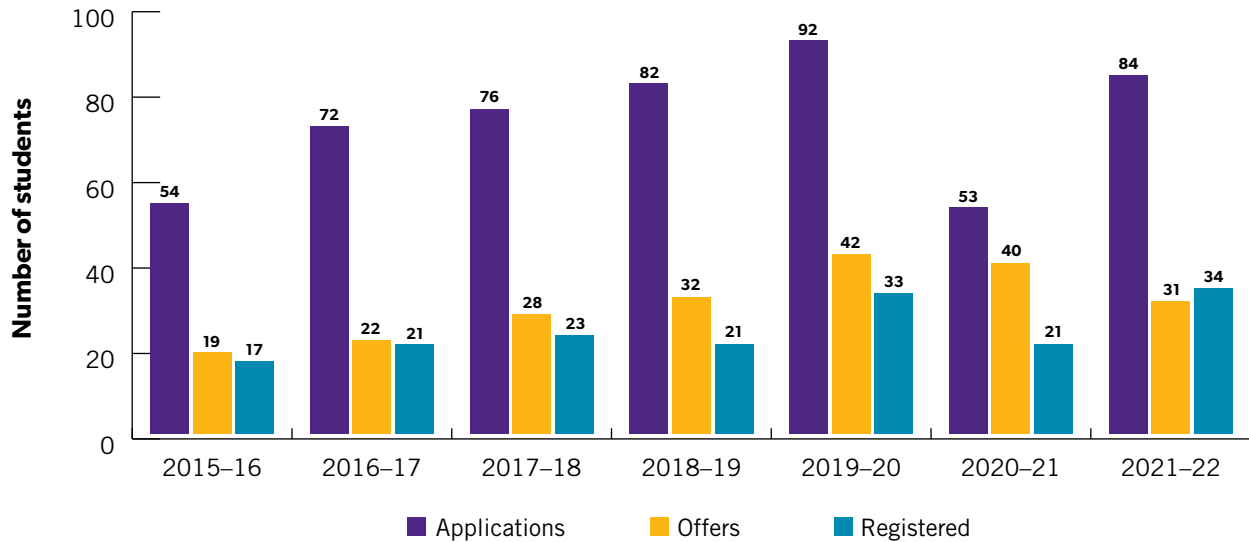

The COVID-19 pandemic had a significant impact on the growth of the program. However, we are hopeful to continue our upward trend as we showcase how we have adapted to the pandemic and take advantage of innovations in virtual learning.

University Graduate Survey

The first university-wide student assessment tool implemented in 2016-17 showed feedback on student satisfaction was at or below IMS averages (prior to the transfer to LMP). We reviewed the program to address the feedback but is important to note that the survey questions appeared to be more relevant for thesis-based research programs. Questions focus mostly on quality measures such as funding, supervision and research related activities and resources, and captured only 6 of 17 students in the inaugural year of a two-year program.

The university conducted a similar survey recently and 67% of our cohort responded. For every question two respondents consistently gave the lowest or the second lowest possible score. This is consistent with our understanding of that cohort and has prompted the program to improve its selection and assessment criteria to attempt to better match student expectations and desired learning outcomes with program deliverables and outputs. We will continue to monitor these scores and supplement them with exit interview data.





Termly teaching assessments

2017–2018

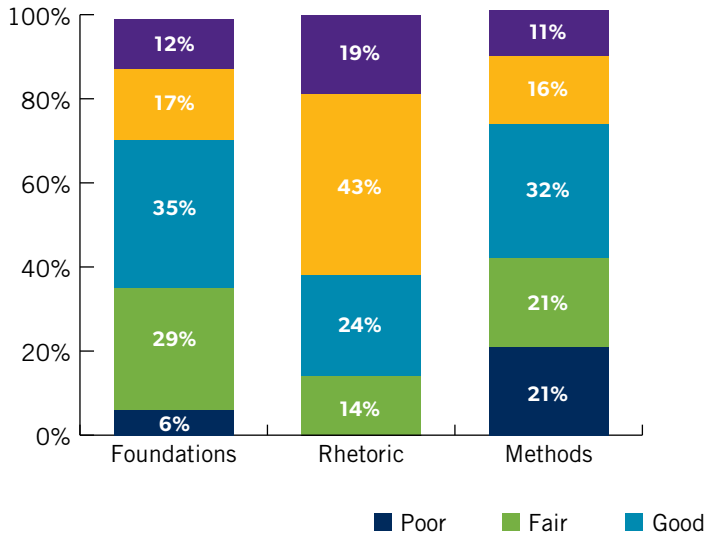

2020–2021

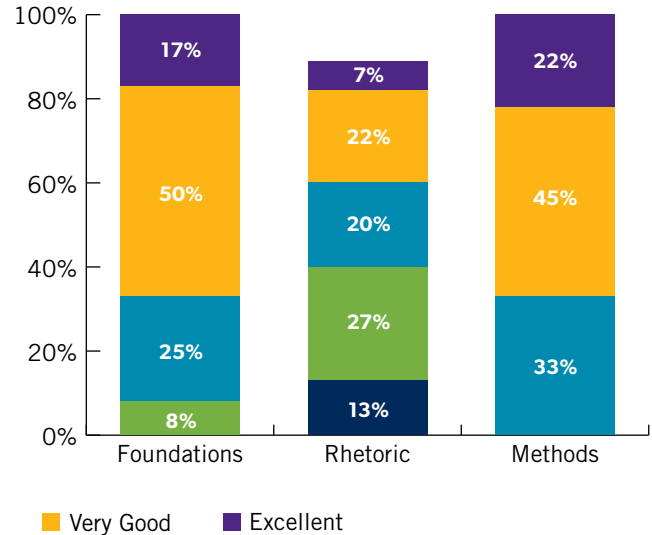

Quality enhancements

In the first three years of program delivery (2015/16–2018/19) we implemented minor modifications to improve the alignment between the courses, learning outcomes and degree level expectations.

During the last program review in 2017–18, the reviewers recommended that the TRP be moved from IMS to a new department. As part of this administrative move to LMP we reviewed the entire TRP curriculum and revised where appropriate, which was approved at the departmental and faculty levels (see Appendix 1.4.1: TRP Curriculum Guide). We improved the integration of courses, assignments and learning outcomes across the program and revised the TRP curriculum map. All instructors contributed to its re-development and we direct all new instructors to adhere to the overall structure and encourage them to contribute further to its development.

Delivering an integrated program proved especially challenging during the pandemic, not so much because of the change in delivery, but in the mechanism of coordination between instructors. This is a key challenge for the coming session to ensure that topics and assessments are in sync among all courses.

How we review quality

Every summer we review the curriculum map (in our teaching retreat) to address feedback, improve logistical challenges, and increase opportunities for independent learning. We consciously try to tailor some of the seminar content, examples, and activities to reflect the backgrounds, interests and career paths of the incoming cohort while balancing the overall learning outcomes of the program.

We collate feedback from students through:

- Discussion ambassadors: students who help establish, communicate and evaluate learning outcomes for each class session, and the incorporation of student representation on the TRP Program Committee to refine our strategies for program delivery.
- TRP Townhalls: We held a Townhall in February 2020. Current students, instructors, and alumni participated in a series of discussions to gain insight and feedback on the student experience during COVID-19 and the program overall. We produced a summary that was shared with the students and discussed with the TRP Program committee to see which feedback we could address in the short-term and which we could incorporate into future strategic planning (see Appendix 1.4.5 for summary of feedback).

4 MHS in translational research

- We conducted a student survey in summer 2021 regarding delivery of the program during COVID-19 in 2020/21 and used the results to inform the choice of delivery mode in fall 2021.
- Seminar surveys: core classes including 'LMP2300: Foundations in TR' and 'LMP2301: Projects in TR' use post-class surveys to assess whether we met session learning objectives. The feedback is gathered and aggregated to provide the course directors with insights into what might need to be discussed in the following seminar.

Recent enhancements based on feedback

- Amending the program schedule to include breaks between classes
- Encouraging a greater focus on integration between cohorts for peer mentorship
- Focussing on more consistent assessment between instructors.

TRP internal student surveys and focus groups

We also have used focus groups to solicit student feedback.

Curriculum Focus Group (June 2017): students from the second cohort discussed strengths and weaknesses of the TRP curriculum. Eight students participated and represented recent graduates, PhD researchers and clinicians.

Strengths identified:

- Exposure to a wide range of high-profile guests from across the cell-to-society spectrum.
- The flexibility of curriculum and teaching staff to adapt to the needs of a cohort.

Weaknesses identified:

- Senior high-profile guests who were 'intimidating' to approach.
- Too much fluidity and instability in the curriculum - no text/notes.
- An overly demanding workload with too many assignments.
- Not enough coordination and integration between courses.

What we did

- Reworked the TRP curriculum map to improve integration of courses.
- Restructured 'LMP2300Y: TR Foundations' to mirror a 'backwards' approach – starting at the endpoint and working backwards through the valleys of death to show the barriers to innovation. This allowed the curriculum to incorporate frontloading of translational tools in the first semester. However, this approach proved a bit disorientating for some students and we have returned to a more linear approach of looking at barriers to translation from funding science to implementing innovation in the community.

Clinician Feedback Focus group (October 2017): Led by Norman Rosenblum, the former Associate Dean of Physician Scientist Training in Temerty Medicine, and included four TRP clinical students, two clinical fellows and two Assistant Professors from four different hospitals, of which three were current TRP students and one alumnus.

The reported themes from the session included a need to:

- clearly articulate the value of the TRP for clinicians who may wish to enroll.
- provide clinicians with focused content that reflects their unique needs when compared to others in the cohort (e.g., particularly recent BSc/BA graduates).
- introduce a clinical stream that includes a reduction in requirements to acknowledge the level of experience and time commitments that clinicians have during the program.
- reduce the number of required modules and elective courses.

What we did

- Restructured the program timetable which has seen many clinicians since 2018 finish all program requirements (excluding their capstone and some electives) before the start of the second year.
- Provided clinicians with more personalized support and feedback - for example, the IDPs.
- Integration of a clinician-focused case-study group with Medical Innovations Toronto (planned for 2021–22 academic year).
- Provided more access to AI materials for clinical research (planned for 2021–22 academic year).

We saw a significant improvement in the feedback from physicians in the 2019 cohort regarding the opportunities



in the program, but we need to do more work to ensure appropriate support and resources are devoted to our clinical students without creating two tiers.

Student survey (November 2017): a group of students scheduled a meeting to discuss Year One workload issues. During the meeting, they presented a student-initiated survey with a 67% response rate detailing some of the concerns that students had about the TRP curriculum.

Specifically, the students articulated concerns about:

- the amount of work involved in peer-review for reflection assignments using a software package called “PeerScholar”. The students expressed concern about the amount of work in the four-step process of submitting, peer evaluation, revision, and resubmission.
- the amount of work involved in the LMP2322H writing course because they felt that it was ‘not necessary’ to have a rhetorical analysis paper in addition to weekly posts.
- the number and variety of groups throughout all the classes (especially for students with clinical duties).
- the need for clearer learning objectives and better preparation by discussants in the MSC 1000 Foundations course.

What we did

- Despite the pedagogic value that PeerScholar provided, the additional work for the students and instructors that the software created was deemed excessive at the time and it was not used the following year.
- The rhetorical analysis assignment was integrated with the final paper in Foundations and instead the students were asked to develop a community focused project proposal for a group project.
- In the subsequent year we attempted to standardize the composition of groups across classes in the first semester. This resulted in feedback concerning the lack of variety and inability to choose team members. So, in 2019, instead of consistent groups throughout the semester we tried having groups across days – Tuesday groups and Thursday groups. The issue of maintaining groups between classes has not come up in any significant way since.
- To ensure better organization, the guest discussions were spun into a lecture series called TR Talks. The notion behind TR Talks was that we could invite speakers for specific preset topics that paralleled the curriculum. This allowed for the seminar in the class to be used for directed discussions based on readings and themes guided by the curriculum.

We note that these represent the expected growing pains of a young innovative program. It is very different than standard University programs that can take students time to get accustomed to.

Further enhancement opportunities

Despite ongoing efforts by our fluid team of part-time and sessional faculty to improve the TRP, there remain many more opportunities for program enhancement.

Establishing a baseline of expectations, learning objectives, assignment rubrics and performance rigor are all key issues that must be addressed. Please see Challenges and opportunities, [page 89](#), for more.

Advance Standing

Feedback from current and prospective students who are clinicians and other health professionals suggests that their existing clinical and or research involvements provide them with knowledge and experiences that supplement some of the materials offered. They have shown concern about the number of required modules and electives in the current structure.

We are therefore considering an “Advanced Standing” stream which may include two specific changes:

1. reducing the number of modules required from eight to four; and
2. removing the requirement of elective courses.

This change would reduce the course credit requirements by 25% (from 8 FCEs to 6 FCEs) and allow all core course work to be accomplished during the first two terms of the program, enabling them to spend three terms exclusively focused on their capstone projects. This approach would have the added benefit of establishing a TRP path where international trainees could finish the bulk of the program requirements locally and execute a capstone project remotely, requiring only one year of living in Toronto.

Equity, Diversity & Inclusion (EDI)

The TRP is founded on human-centered principles that attempt to reduce cognitive bias and expand an individual's point of view to accept multiple interpretations. This has been a core element of our program: to really help the people you are trying to help, you need to empathize and understand their lived experience instead of imposing your own assumptions and unconscious biases. This forms the philosophy behind "Discovery" and the "Unlearn" stages of the TTF (Toronto Translational Framework™). See Appendix 1.4.6: Toronto Translational Framework.

Although the program has been relatively diverse since its launch in 2016, the formation of the TRP Anti-Racism Committee (ARC) and an early survey they administered demonstrated that the program is far from perfect.

Over the past year, we have actively attempted to include a more diverse range of guests, speakers, panelists, and topics across the curriculum. We have worked with ARC to support the development of a Modular Course around EDI issues and have committed to several key initiatives to advance EDI in health – this includes supporting the development of a Centre for EDI research in healthcare delivery being proposed on the U of T Scarborough campus.

Student Awards

The TRP is a professional graduate program and not subject to the harmonized stipend agreement that pertains to students in thesis-based MSc/ PhD programs within Temerty Medicine.

TRP students pay a professional tuition rate and are not paid stipends during their course of study. As they are designated as professional students, they are not eligible for several funding awards offered by the Tri-council agencies to students in research-focused graduate programs.

Despite this, TRP students have been both resilient and persistent in looking for awards and funding. They have received multiple Ontario Graduate Scholarship (OGS) and Canada Graduate Scholarship (CGS) awards, and most significantly have increased the number of Social Sciences and Humanities Research Council (SSHRC) award allocations to our department.

Program-related student awards:

Year	Value
2016	\$58,000
2017	\$54,000
2018	\$65,000
2019	\$47,500
2020	\$84,500

Our students' funding awards and accolades have included:

- Ontario Graduate Scholarship (OGS) and Canada Graduate Scholarship (CGS) awards,
- an increase in the number of Social Sciences and Humanities Research Council (SSHRC) award allocations to our department.
- [Mitacs internships](#)
- Bio Talent internships
- a student received a MaRS Innovation award of \$10,000 plus an internship salary.
- a Horizon's grant from Economic Development Canada (\$5,000 to support senior social connectedness programming)
- project grants totaling \$55,000 in 2020-21 (e.g. CABHI - Centre for Aging Brain Health Innovation)
- In 2020-21 and 2021-22 AGEWELL, partnered with the TRP to provide students with a tuition award of \$10,000.

The program has also received a small donation (\$50,000) from an estate to help with student tuition and now has a professional bursary program from LMP to support needs-based emergency financial support.

As a program, we have made coordinated efforts to increase opportunities for students to obtain funding by organizing workshops and facilitating networking. We are further exploring funding mechanisms for students and projects, such as funding for community-based research and workplace learning.



Challenges and opportunities for the program

Identity and branding

The growth and diffusion of “translational” activities in the health sciences represent the greatest strength and challenge for the future of the TRP. The ability to clearly articulate the features of the program, its specific academic niche and its benefit to students is extremely important.

Establishing and stabilizing the identity of the TRP continues to be a work-in-progress. We need to find a way to extend our profile globally as the “translational” program for health innovation, as well as articulating it clearly within the Faculty, to the community and to prospective students.

Diversity of the program

A core strength of the TRP, its multidisciplinary nature continues to also be a challenge. It requires the right type and variety of faculty and students, with appropriate institutional opportunities and support. Multidisciplinary programs represent a challenge for assessment, communication, rigour, and coordination. From the requirement to create our own framework to the creation of an appropriate intellectual space with atypical academic freedoms, multidisciplinary collaboration, and innovation, will continue to present challenges for the program.

The great diversity in the backgrounds, ages, experience, and career stages of TRP students have clearly demonstrated the need for more suitable streams within the program. It has become clear that different constituent students in the program require personalized supports for their learning experience to be more relevant and impactful - the needs of a physician are very different to a recent bachelor’s degree graduate. A significant challenge facing the TRP is how to catalyze inclusion and interdisciplinarity while still providing personalized experiences.



Assessment and feedback

With a focus on innovation and self-directed learning, where the value of the learning, associated competencies and deliverables are of subjective and contextual value related to the goals of the learner, traditional assessment approaches cannot be applied. How do you assess innovation? How can a small program provide training, rigour, and consistent evaluation of these approaches to ensure they are effective and impactful? There is a significant movement towards understanding how experiential learning and innovative thinking can be integrated into teaching and learning, and we can make a strong contribution to this.

Grading continues to be a challenge as faculty and students tend to be unfamiliar with how to assess competency-based learning.

Key to overcoming these challenges is continued faculty development. We need to establish a core faculty with a coherent sense of the program's philosophy and approach.

Stabilizing teaching

As mentioned above in reference to assessment, our dependence on yearly contracts and casual staff has created instability since the program's inception. The lack of stability is a great challenge for consistent content delivery, assessment and improvement, and sustainability. Inconsistencies in pedagogy and approach have caused frustration and confusion for students when a core message of one instructor is contradicted by a teaching assistant or a course instructor from another course.

Since moving to LMP, we have made significant strides in correcting this. For example, on July 1, 2021, LMP hired a full-time CLTA (contract-limited term appointed) TRP faculty member on a two-year term, renewable up to five years. This represents the program's first full-time faculty member since its inception and indicates a significant positive step towards stabilizing the future of the TRP.

Faculty development and recognition are also key challenges. We need mechanisms to engage with the greater community of faculty and researchers at LMP, Temerty Medicine and across U of T, to encourage them to engage as discussants, case-study leaders, mentors, capstone advisors and project partners. For example, capstone project supervision is different from supervision of a particular student in a research lab. Supervising a capstone often involves a group and is unlikely to be related to the TRP supervisor's area of direct expertise. This type of supervision is neither teaching nor traditional lab-based supervision.

Remote collaboration

One of the take-away lessons of COVID-19 is the potential for, and the value of, remote collaboration. Trainees, researchers, and professionals who have the skills to collaborate with teams across geographic boundaries will undoubtedly generate interest and value. We need to explore how the program can link trainees and researchers to form in-person, hybrid, and entirely virtual collaboration teams.

Engaged partnerships

It is critical to commit to forging and maintaining partnerships with constituencies across academic, government, community and industry boundaries that support experiential learning, knowledge exchange and mobilization for the benefit of improving health across a range of stakeholders.

Locally, we have made significant progress in establishing partnerships. Within the University, interactions with other professional programs, campus-linked and other academic units have resulted in numerous collaborations, shared teaching resources and materials, and opportunities for TRP students. These local partnerships already contribute to the depth and robust nature of the TRP and are being strategically consolidated and positioned around a translational consultancy strategy.

We have started to incorporate the above partnerships into case-studies and partner projects, and plan to strategically integrate the relationships into capstone projects and internship opportunities for students. Future considerations may involve a co-curricular student-staffed strategic translational consultancy focused on developing, implementing, and evaluating health science innovations in research and clinical contexts.



5

Clinical and Professional Education

MHSc in Laboratory Medicine

The key purpose of this professional graduate program is to provide academic graduate level education to prepare well-trained students for practice in the Pathologists' Assistant (PA) or Clinical Embryology (CE) disciplines in clinical laboratory medicine.

Pathologists' Assistants
(PAs) are involved in providing diagnostic services in anatomical pathology by applying knowledge of tissue and laboratory analysis of human specimens.

Clinical Embryologists
(CEs) provide clinical management related to assisted reproductive technology in clinical embryology laboratories.



We aim to teach general core knowledge in laboratory medicine and specific basic and applied principles and skills in anatomic pathology or assisted reproductive technology (ART) required to work as high-quality laboratory scientists.

Previously, PAs and CEs were trained in an apprentice-type approach in the laboratories where they were hired. This approach focused on practical knowledge and lacked an academic curriculum to provide basic foundational knowledge. The medical disciplines of pathology and obstetrics and gynecology (OB-GYN), whose members supervise and are responsible for PAs and CEs respectively, now require a much higher level of education as clinical responsibilities of the PAs and CEs are expanding and becoming more complex in scope and nature. The design of the program provides graduate level education which is now becoming the preferred educational route to train clinical scientists to practice these disciplines in a safe and competent manner.

Over the two-year program both PA and CE students attend 4.0 FCE core courses, plus 5.5 FCE courses for each discipline.

The core educational values are to:

- acquire an understanding of the foundational body of knowledge of each discipline
- develop the practical skill sets required to practice in a competent manner to deliver excellent health care
- create life-long learners

The values are embodied in the ability to:

- solve complex problems
- make evidence-based decisions
- understand and apply ethical concepts
- develop a strong sense of personal accountability, intellectual rigour and independence.

The learning environment in the program and in our department stresses both broad overview and in-depth study of scientific principles that form the foundation of these clinical disciplines. This is accomplished through didactic teaching and the requirement for students to prepare presentations, reports, and debates on relevant topics.

The physical learning environment is spread across the university campus and its teaching hospitals:

- Our faculty in pathology departments of teaching hospitals deliver the experiential clinical program for PAs
- We have developed a unique Clinical Embryology Skills Development Laboratory (CESDL) located on campus to deliver the experiential clinical program for CEs.
- Students also attend a Forensic practicum (6 weeks) at the Ontario Forensic Pathology Service (OFPS). More on the OFPS in Residency Training Programs, [page 119](#).

We include our strong research mandate by teaching our students to read research papers, be critical in assessing research and to do some original research investigations on a topic of their choosing in their capstone project.

We aspire to achieve an international reputation for our MHS in keeping with the high global rankings of Temerty Medicine programs. We have modeled the MHS curriculum on educational programs in LMP that have a strong successful record in teaching at the undergraduate, graduate and medical school level, and which are aligned with the educational mission of U of T.

Learning outcomes

Content knowledge of the fundamental concepts of pathogenesis of disease and of infertility, especially at the cell and molecular level, is a very important outcome. A major goal of the program is to have the students understand why they carry out their practical work and how to be critical using fundamental knowledge to assess new techniques and technologies. These outcomes align with graduate level education.

Expertise in professional skill sets

Our students develop expertise in the professional skill sets required to practice the two disciplines, PA/CE.

We do this through

- Practicums and laboratory rotations offering hands on learning, didactic teaching and self-learning instruction, both independent and peer-to-peer.

Critical research skills

We teach critical research skills to both interpret current research and to plan original research independently. Understanding the principles of research is essential since these two disciplines are dynamic and constantly incorporating new concepts and techniques to improve healthcare.

We do this through:

- Courses that promote medical research, 'LMP 2001H: Biomedical Research Methods', 'LMP2004H: Introduction to Biostatistics', 'LMP2208H: The Science of Bio-banking', and 'LMP2105H: Innovation in Assisted Reproductive Technology (ART)'
- The Capstone Project (LMP 2005Y), spread over the last three terms, pulls together the knowledge acquired in the fundamental sciences mentioned above. Students apply their knowledge to an important question to be answered scientifically. They will first identify a gap in scientific biomedical knowledge to explore and then learn to design and analyze research protocols. The Capstone involves considerable communication opportunities and teaches students to be critical and defend their scientific and applied ideas in front of peers and faculty. Students produce a final report in the format of a scientific journal article.
 - » PA students will use the fundamental knowledge gained in 'LMP 2200H: Basic Principles in Human Pathobiology and Pathophysiology', 'LMP 2201H: Anatomy and Pathology of Organ Systems' and 'LMP2211H: Advanced Anatomy Dissection' to choose an area to work on.
 - » CE students will be guided by the material in 'LMP 2107H: Foundations of ART'.

Practicing integrity, ethical behavior, personal accountability

Understanding and practicing integrity, ethical behavior, personal accountability is aligned with both the didactic courses and the practicums and laboratory courses.

We do this through:

- The early introduction of 'LMP 2003H: Biomedical Ethics' sets the stage for the type and quality of discourse and professional behavior expected of the students, as well as 'LMP 2001H: Biomedical Research Methods'. Ethical considerations transcend virtually all aspects of laboratory science education

including research ethics, diversity, consideration of respectful handling of human tissues, and professionalism in interactions with colleagues and patients.

Creating life-long learners

The creation of life-long learners and critical thinkers is aligned with the graduate experiences of carrying out critical reviews of the scientific/clinical literature, presenting literature reviews and debating/discussing controversies in the discipline.

We do this through:

- Offering curricular and extra-curricular opportunities to develop skills related to teamwork, building communities of peers, and networking.
- Teamwork through learning opportunities and projects teaches skills of collaboration and team-based problem solving.
- The students also learn mentorship by being mentored by faculty during the program.

Admission requirements

We accept currently five PA and five CE students per year.

They must have:

- a strong academic transcript especially in the final two years of an undergraduate degree in the sciences.
- evidence of success in the life sciences, both through didactic courses and project/research courses. These are important since they provide a strong foundation for the advanced life sciences and pathogenesis material in the MHS curriculum.
- a strong background in life science courses such as anatomy, physiology, cell and molecular biology, biochemistry, immunology, and statistics to provide them with a foundation on which to build the knowledge they will acquire on human anatomy (especially 'LMP2211H: Advanced Anatomy Dissection'), cell and molecular biology, pathology and pathogenesis of basic disease processes.

We value extra-curricular experience in jobs demonstrating leadership, teamwork and interactions with the public.



Curriculum design

The program design and requirements provide opportunities for our students to develop written and oral communication skills through class presentations and written assignments. These have been incorporated into all courses in the program.

Field	Year	Course Code	Course Title
Core	Year 1 F	LMP2000H	Cell and Molecular Biology
Core	Year 1 F	LMP2001H	Biomed Research Methods
Core	Year 1 F	LMP2004H	Intro to Biostats
CE	Year 1 F	LMP2100H	Adv Reproductive Physiology
PA	Year 1 F	LMP2200H	Basic Principles in Human Pathobiology and Pathophysiology
Core	Year 1 W	LMP2002H	Clinical Lab Management
Core	Year 1 W	LMP2003H	Biomedical Ethics
CE	Year 1 W	LMP2102H	Foundations in ART
PA	Year 1 W	LMP2201H	Anatomy and Pathology of Organ Systems
PA	Year 1 W	LMP2208H	The Science of Biobanking
PA	Year 1 W	LMP2211H	Advanced Anatomy Dissection
CE	Year 1 W	MSC1008H	Human Embryology
CE	Year 1 S	LMP2103H	Reproductive Genetics
CE	Year 1 S	LMP2104H	Applied Methods in ART
PA	Year 1 S	LMP2202H	Practicum in Surgical Pathology I
PA	Year 1 S	LMP2203H	Practicum in Surgical Pathology II
Core	Year 2	LMP2005Y	Capstone Research Project
CE	Year 2 F	LMP2105H	Innovation in ART
CE	Year 2 F	LMP2106H	Current Topics in Causes and Treatment of Infertility
CE	Year 2 F	LMP2108H	CE Lab Simulation I
PA	Year 2 F	LMP2204H	Practicum in Surgical Pathology III
PA	Year 2 F	LMP2205H	Practicum in Surgical Pathology IV
CE	Year 2 W	LMP2107H	Applied ART Lab Decision Making
CE	Year 2 W	LMP2109H	CE Lab Simulation II
PA	Year 2 W	LMP2206H	Practicum in Autopsy Pathology
PA	Year 2 W	LMP2207H	Practicum in Forensic Pathology
CE	Year 2 S	LMP2110H	ART Lab Rotations
PA	Year 2 S	LMP2209H	Practicum in Surgical Pathology V
PA	Year 2 S	LMP2210H	Practicum in Surgical Pathology VI

Core
CE
PA

F = Fall Term
 W = Winter Term
 S = Summer term

Students will develop and defend a research proposal relevant to their field as part of their capstone project. LMP2005Y is a continuous course where students will learn how to give a strong presentation and how to write an effective proposal, strengthened with feedback provided by preceptors and instructors, to culminate in a finished project. For CE students, written research summaries and presentation are a fundamental component of 'LMP2106H: Current Topics in Causes and Treatment of Infertility'. They will also learn communication of knowledge translation in the interactive 'LMP2107H: Applied ART: Laboratory Decision Making'. We ask students to evaluate the work of their peers to embed their learning.

CE students must learn to communicate with peers within the embryology lab, between various team members within the ART clinic, and with patients. It is essential for the delivery of safe and appropriate patient care and so they can simplify complex procedures and concepts to other ART team members and/or patients. We work towards this in multiple courses within the program. Simplification of complex genetic testing information is discussed in 'LMP2103H: Reproductive Genetics' and increasingly complex laboratory procedures in 'LMP2104H: Applied Methods in ART' and 'LMP2105H: Innovation in ART'. Communication of complex information is a focus of the capstone project, and by its completion, students should demonstrate a level of expertise in this skill. Their preceptor will evaluate them on these skills during their clinical lab rotation.

For PAs, we introduce communication with the full pathology team, including other PAs, supervising pathologists, and technicians in 'LMP2002H: Practicum in Surgical Pathology I' and applied in the practicum series.



Depth and breadth of knowledge

A systematic understanding of knowledge, and a critical awareness of current problems and/or new insights, much of which is at, or informed by, the forefront of the academic discipline, field of study or area of professional practice.

Core outcomes

Understand the fundamental cell and molecular biology principles of pathology and reproductive technology used in the clinical laboratory.

- Identify gaps in knowledge that lead to research and clinical investigations.
- Understand the principles of laboratory quality assurance.

CE-specific outcomes

- Understand reproductive physiology and the underlying pathophysiology leading to common causes of infertility.
- Know current ART procedures, their indications, strengths, and limitations.

PA-specific outcomes

- Identify and list the etiology and pathogenesis of human diseases.
- Recognize tissue specimen variation and decide which laboratory approaches are best suited to each type of variation.

How our program design achieves these outcomes

We introduce molecular and cell biology in LMP2000H and how it is applied in human embryology in LMP2100. These principles are also applied in the understanding of the genetic underpinnings for fertility and reproductive diagnosis in 'LMP2103H: Reproductive Genetics'. These courses combine didactic lectures with student presentations.

A central philosophy of the program is to question the known literature and to be self-reflective. In all courses, but particularly the later courses, instructors encourage this kind of critical and reflective thinking in students through student presentations and discussions.



Quality assurance is a critical practice for all clinical laboratories. Fundamental knowledge of quality assurance is provided in 'LMP 2002H: Clinical Lab Management', and this knowledge is applied in courses 'LMP2104H: Applied Methods in ART' and 'LMP2105H: Innovation in ART' for CE students and throughout all the practicum series for PA students (LMP2202H to LMP2210H).

CE students:

- understand how molecular and cell biology will be applied in 'LMP2106H: Current Topics in Causes and Treatment Infertility' as they study and critically discuss emerging literature relevant to clinical embryology.
- are introduced to causes of infertility in the first three terms. This general information is reinforced with a deeper understanding through critical analysis of current relevant literature in LMP2106H.
- learn the general approaches to infertility treatment in 'LMP2100H: Advanced Reproductive Physiology'. Specific aspects of each of these approaches as they pertain to the andrology and embryology laboratories will be presented in 'LMP2102H: Foundations in ART' and 'LMP2104H: Applied Methods in ART'. This will be applied in 'LMP2105H: Innovations in ART' as students explore and discuss nascent changes in existing technologies and the impact of technological advances.
- develop decision-making skills as to the appropriate application of existing techniques in 'LMP2107H: Applied ART Lab Decision Making'.

PA students:

- integrate cell biology in the understanding of human pathology as types of disease categories are introduced in 'LMP2200H: Basic Principles in Human Pathobiology' through didactic lectures. 'LMP2201H: Anatomy and Pathology of Organ Systems' builds on some aspects of LMP2200H and focuses on disease in certain organs and tissues.
- are presented important context to view and classify disease conditions. LMP2000H: general to normal cell and biology; LMP2200H: general to disease; LMP2201H: disease in organ systems.
- receive practice by organ system. They begin learning about each organ tissue type at the introductory level and progress to intermediate and then to expert as they move through the program.

Research and scholarship

A conceptual understanding and methodological competence that enables:

- a working comprehension of how established techniques of research and inquiry are used to create and interpret knowledge in the discipline;
- a critical evaluation of current research and advanced research and scholarship in the discipline or area of professional competence; and
- a treatment of complex issues and judgments based on established principles and techniques; and, on the basis of that competence, has shown the development and support of a sustained argument in written form, and/or originality in the application of knowledge.

Core outcomes

- Critically read and interpret research and clinical literature in the disciplines of pathology or ART.
- Understand the principles involved in developing a viable research proposal.
- Critically assess technologies for their appropriate use and effectiveness.

How our program design achieves these outcomes

We introduce students to overall research approaches in LMP2000H and LMP2001H, which are built upon in 'LMP2004H: Intro to Biostatistics'. These courses provide the basic tools to critically review the relevant literature within their respective streams. CE students will learn about examples of key studies leading to development of laboratory procedures in the embryology lab in terms three and four and apply their reviewing skills in LMP2106H and LMP2107H, putting the skills into practice in their capstone project. PA students will use the core courses to form the basis for further critical literature review and interpretation necessary for their capstone project.

We introduce concepts that will enable them to produce a viable and defensible research plan/proposal in 'LMP2001H: Biomedical Research Methods', and the need to obtain appropriate research ethics board approval in 'LMP2003: Biomedical Ethics', covering statistical testing and how it impacts experimental design in LMP2004H. The students apply this knowledge in developing their own research plan in their capstone project (LMP2005Y). For PA students this will include a clear understanding of the role and importance of the biobank in research.

The ability to critically assess existing and emerging technologies and apply them appropriately is an important element in the expectations of a clinical laboratory specialist. We introduce all students to research evaluation in LMP2001H. PAs apply this in LMP2203H and CEs are exposed to technologies relevant to embryology in 'LMP2102H: Foundations in ART' with a more critical view taken in 'LMP2104H: Applied Methods in ART' and 'LMP 2105H: Innovation in ART'. In 'LMP2107H: Applied ART Lab Decision Making', students learn to apply this knowledge to making clinical care decisions/recommendations. Both PA and CE students need to appropriately apply experimental or clinical technology for their capstone project. We expect their level of expertise to advance as the capstone project progresses.

Application of knowledge

One overall goal for the students' learning is to develop competence in the research process by applying an existing body of knowledge in the critical analysis of a new question, specific problem or issue.

Core outcomes

- Know when and how to use statistical tests.
- Apply quality assurance processes in the clinical lab.
- Recommend and justify the need for follow-up evaluation and/or procedures based on initial findings and clinical context.

CE-specific outcomes

- Assess oocytes, sperm, and embryos.
- Perform laboratory techniques used in ART.

PA-specific outcomes

- Interpret clinical pathology results with an understanding of the inherent strengths and limitations of an individual procedure.
- Use patient medical and hospital records to guide clinical work.

How our program design achieves these outcomes

It is important to understand fundamental statistical principles to critically evaluate literature and for clinical purposes. Knowing when and how to use statistical tests is a vital part of both roles.

CE students:

- are introduced to the concept of grading and the general principles of gamete and embryo assessment in 'LMP2102H: Foundations in ART'. The ability to assess gamete and embryo quality based on qualitative and quantitative histomorphologic and behavioural (e.g. sperm motility) parameters is a fundamental task performed by all practicing clinical embryologists.
- learn about the application of evaluation criteria in detail in 'LMP2104H: Applied Methods in ART' and apply them in the Clinical Embryology Skills Development Laboratory (CESDL) 'LMP2108H: CE Lab Simulation I' and 'LMP2109H: CE Lab Simulation II', where we expect them to show proficiency and accuracy in these evaluations. They will then observe and, in some cases, participate in the evaluation of gametes and/or embryos in the practicing clinical embryology lab as part of 'LMP2110H: ART Lab Rotations'.
- receive directed practice in ART laboratory techniques in the CESDL, allowing us to ensure the student develops a beginner level "hands-on" technical skills in common procedures required by potential employers.

PA students:

- must have the ability to critically read a patient's chart, using the clinical history and laboratory findings to guide the examination and submission of appropriate tissue specimens for microscopic examination, including any special procedures (e.g. molecular analysis). They develop these skills in each practicum as they relate to specific organ systems, becoming more adept at interpreting the charts and performing a clinical pathology correlation.
- are exposed to the basic principles in gross dissection and interpretation in 'LMP2200H: Basic Principles in Human Pathobiology' and 'LMP2201H: Anatomy and Pathology of Organ Systems'. The practicum series covers variations in assessments of specific tissue types and diseases.

Quality assurance is an integral part of any clinical lab. We introduce students to quality assurance practices in the clinical lab and their importance in core course 'LMP2002H: Clinical Lab Management'. These principles are expanded upon in field-specific courses as specific aspects diverge between the pathology and embryology laboratory.



CE students:

- learn discipline-specific practices in LMP2102H, further in-depth in 'LMP2104H: Applied Methods in ART', and in 'LMP2107H: Applied ART Lab Decision Making', in a coordinated fashion.
- gain practical skills by performing standard quality assurance testing as part of their CESDL training (LMP2108H and LMP2109H) where they become proficient in monitoring key quality procedure parameters.
- observe and participate in quality assurance procedural monitoring in an active operational clinical embryology laboratory as part of their clinical lab rotation (LMP2110H).

PA students:

- cover standards for autopsy dissection and forensic examination in 'LMP2206H: Practicum in Autopsy Pathology' and 'LMP2204H: Practicum in Surgical Pathology II'.

Decision-making in ART is the shared purview of the two care providers: embryologist and physician. These decisions are the responsibility of the attending physician, so an intermediary level of competence is the expectation of the program of the human component of the decision-making compared to the cell component.

CE students:

- are introduced to important concepts that form the knowledge base to meet this challenge throughout their training.
- learn how this is applied in 'LMP2102: Foundations in ART' and 'LMP2104: Applied Methods in ART', then strengthened and evaluated in 'LMP2107H: Applied ART Lab Decision Making'.

PA students:

- are taught to search for and identify areas for follow-up evaluation in the practicum series. This skill builds as the practicum progresses and will focus on specific organ systems.

Professional capacity/autonomy

- The qualities and transferable skills necessary for employment requiring the exercise of initiative and of personal responsibility and accountability; and decision-making in complex situations;
- The intellectual independence required for continuing professional development;
- The ethical behaviour consistent with academic integrity and the use of appropriate guidelines and procedures for responsible conduct of research; and
- The ability to appreciate the broader implications of applying knowledge to particular contexts.

Core outcomes

- Know and be able to apply ethical standards for clinical laboratory science.
- Know and follow the professional guidelines for communication of clinical findings.
- Appreciate the consequence of growing availability of cell and molecular biology information on clinical medicine.
- CE students must understand how embryologists can provide patient centered care.



A simulated teaching environment years in the making gives students a COVID-safe space to learn.

We have just opened a new simulated clinical laboratory to teach embryology students on our MHS in Laboratory Medicine: the Clinical Embryology Skills Development Laboratory (CESDL).

"What we needed to make our program unique was the ability to train people in a controlled environment." Says Dr. Heather Shapiro, Clinical Embryology Field Director, "Clinical embryology labs are not necessarily geared up to teach students in a dedicated manner that is safe for both the students and the patients."

How our program design achieves these outcomes

Ethical practice and adherence are basic tenets of professionals. Our students study the situation-specific aspects of laboratory medicine, pathology, and fertility.

PA students:

- Gain knowledge of standards including consents, scope of analysis, and use of tissue for research across several courses.

CE students:

- study the legal framework within which the profession practices (Assisted Human Reproduction Act) and the application and relevance, in particular procedures and approaches, in LMP2104H, 2105H, and 2107H.

Communication of clinical findings, maintaining patient confidentiality, and respect is a common element for both fields. Basic principles are introduced in 'LMP2003H: Biomedical Ethics', including appropriate legal requirements. Clinical embryologists communicate sensitive information regarding genetic disorders with patients or other healthcare providers. This field-specific aspect is outlined in 'LMP 2103H: Reproductive Genetics', with situational testing on simulated case studies, as well as in 'LMP2107H: Applied ART Laboratory Decision Making'. Confidentiality of the situation and results for PAs becomes a concern for autopsy and forensic pathology and biobanking.

Clinical laboratory specialists are encouraged to consider new technologies and advances in our understanding of disease and their treatment, such as the increasing use of genetic information. A fundamental understanding of cell and molecular biology, presented in LMP2000H will provide the tools needed to appreciate what these changes entail. CE students expand on these concepts as they apply to preimplantation genetic testing and screening ('LMP2103H: Reproductive Genetics') and decision-making (LMP2107H). PA students cover emerging skills for tissue handling and processing for molecular genetic testing in the practicum series.

CE students are taught a heightened cultural awareness, a sensitivity to diversity and appreciation of health inequity as related to infertility care in general, and ART in particular. They learn legal and ethical requirements in 'LMP2003H: Biomedical Ethics' with concepts relevant to ART in 'LMP2102: Foundations in ART', and 'LMP2107: Applied ART Laboratory Decision Making'.

Communications skills

The ability to communicate anatomic pathology and clinical embryology information in a clear, easily understood fashion tailored to the level of understanding of the audience. This is reflected in students who can present critical reviews of appropriate scientific areas and clinical reports on applied topics as part of their clinical workload. Creating research reports on their capstone project, presenting orally, and defending their research work.

Core outcomes

- Create written and oral presentations on research topics and literature.
- Synthesize complex information in written and oral form to present to appropriate stakeholders.

How our program design achieves these outcomes

This is reflected in students who can present critical reviews of appropriate scientific areas and clinical reports on applied topics as part of their clinical workload. Creating research reports on their capstone project, presenting orally, and defending their research work.



Assessment of learning

Fundamental knowledge

- weekly and by mid-term and final quizzes
- presentations
- final in-depth reports.

Professional skill sets

- quizzes
- competency in person evaluations
- observation during work using rubrics to assess knowledge acquisition
- competencies in accessing, evaluating, and sampling tissue using rubrics to assess ART techniques.

Ethics in clinical activities and integrity in learning

- face-to-face observations
- evaluation of class participation including interacting with peers, faculty, staff.

Life-long learning

- ability to read, critically analyze and report on scientific and clinical journal articles

The longer in-depth reports in some courses ('LMP2100H: Advanced Reproductive Physiology' and 'LMP2201H: Anatomy and Pathology of Organ Systems') demonstrate how effective the students are at critically sorting through an important problem in their discipline and synthesizing their findings into a comprehensive report.

Critical thinking

- class participation
- assessment of scientific and clinical journals
- demonstration in reports
- performance in debates on controversial issues.

Performance in building communities of peers, teamwork, and networking

- collaborative work on assignments and projects using rubrics
- participation in service activities in the program and the department and demonstrated interest in mentorship activity.

The full curriculum map is provided in Appendix 1.5.1.

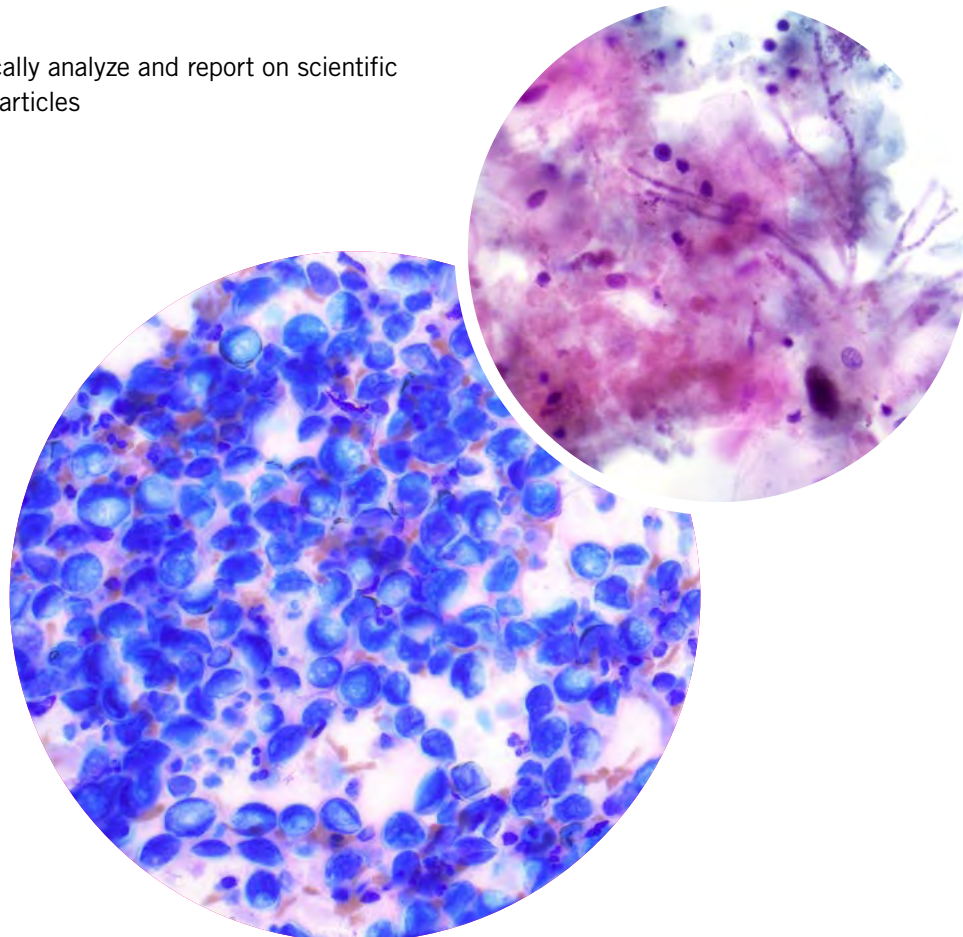



Clinical and Professional Education

Residency Training Programs

We offer several Residency Training Programs. Our primary specialty training programs cover:

- Anatomical Pathology
- Hematological Pathology
- Medical Microbiology
- Neuropathology
- Forensic Pathology (subspecialty)

Our network of affiliated hospitals gives our residents access to outstanding case materials, and our large and diverse faculty gives them access to experts in their field and opportunities to engage in a range of basic, translational and clinical research.

All residents are expected to complete a scholarly project and present their findings locally at the LMP Research Conference (see Research stream graduate program, [page 33](#)) and nationally or internationally at scientific meetings. We actively support them to present at national and international conferences. Opportunities exist for obtaining a formal graduate degree through, for example, the Clinician Investigator Program at U of T.

Our programs fulfill the requirements of the Royal College of Physicians and Surgeons of Canada (RCPS(C)).



Admission requirements

Candidates apply for our primary Residency Training programs through the Canadian Resident Matching Service (CaRMS).

We select our trainees based on:

- academic record
- research experience (for those choosing Anatomical Pathology)
- references
- a demonstrated interest in the field
- interviews

Forensic Pathology as a subspecialty residency program has further requirements on [page 118](#).

Quality enhancement

Each program has a Residency Program Committee (RPC) that monitors and runs the program. We also collect feedback and data across all programs, in partnership with the Postgraduate Medical Education Office (PGME).

Gathering data for quality enhancement

The Anatomical Pathology Residency Program Director is a member of the PGME Continuous Improvement Working Group and reports back to the RPCs on the Group's activities and resources.

Resident rotation reviews in POWER and Elentra are the largest part of programmatic review. Residents have the ability to evaluate all teachers using these online systems and evaluations are stored centrally. They can choose how many and which teachers they will evaluate on a given rotation.

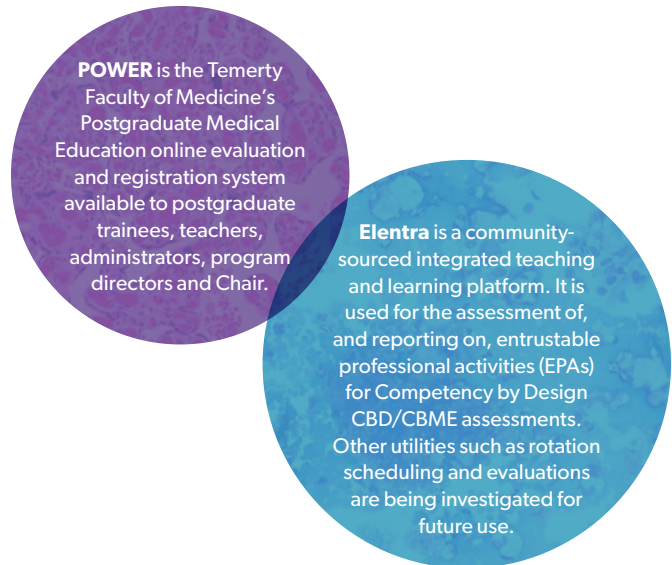

Teachers have access to summary aggregate reports for prior years once a minimum of three evaluations are complete. The Program Director, Department Chair and Postgraduate Education Officer have a higher level of access that allows review of individual evaluations for individual teachers in real time.

How we hear about feedback

- **Real time:** An "alert" system is built into POWER so that identified individuals are alerted whenever a teacher or rotation receives a score below a threshold. These are investigated in real time to ensure there is no threat to resident well-being and educational integrity, and that we take appropriate action.
- **Annual report card:** The PGME office provides a Program Report each year detailing the completion rates for teacher evaluation forms and comparators including year-over-year change and PGME benchmarks.
- **Annual report:** The PGME office provides an annual report that outlines average teaching and rotations scores for each rotation across all hospitals comparing sites and year-over-year change.

In addition to annual program reports, the POWER system allows for regular and ongoing reporting on Rotation Evaluations and Teacher Evaluations (metrics and comments) at any time of the year.

Data from PGME

Data collated centrally is used for program reviews. Each year the PGME Office provides a Program Report to Program Directors with copies to Vice Chairs of Education and Department Chairs.

6 Residency Training Programs

The reports highlight evaluation metrics on an annual basis for the program and include results from the previous four years for tracking purposes.

The metrics provided include:

- In-training Evaluation Reports (ITER)/ In-training Assessment Reports (ITAR) completion rates against targets
- The proportion of ITERS/ITARS signed off by residents
- The proportion of ITERS/ITARS completed within a reasonable time
- The proportion of residents who reported face to face feedback
- Completion rates for Teacher Evaluations (TE)
- Completion rates for Rotation Evaluations (RE)
- Teacher and Rotation Evaluation Completion and mean Overall scores by training site

The annual reports include additional commentary reflecting on their year-over-year performance and invitations to meet with PGME faculty and staff to discuss results. These comparative reports are now available to programs more frequently such as quarterly or biannually.

Both TE and RE tools have been reviewed and standardized to optimize the quality of information collected and to allow programs to compare performance of their teachers and their sites in the delivery of residency education.

Program Evaluation for Competence by Design (CBD) Programs

Competency-Based Medical Education (CBME) is an outcomes-based educational model that emphasizes the demonstration of competence in key skills and abilities deemed essential for future practice and de-emphasizes time.

All our Residency Training Programs will transition to CBD over the next few years. Some of our programs already use this model (Forensic Pathology), some have begun introducing it (Anatomical Pathology), and some are planning the transition (Hematological Pathology, Neuropathology, Medical Microbiology).

In addition to regular reporting from POWER, programs that have fully or partially launched CBD at the University of Toronto receive regular learning analytics related to the delivery of the new curriculum based on our IT platform, Elentra.

Elentra can track:

- the total number of assessments triggered
- assessments completed
- method of completion
- time from initiation of the assessment to completion
- the performance of faculty in completing assessments and patterns of entrustment.

Remediation

Remediation is a formal program of individualized training aimed at assisting a trainee in correcting identified weaknesses. We anticipate those weaknesses can be successfully addressed to allow the trainee to meet the training standards.

Clinician Scientist/Investigator training programs

We promote and advocate for all residents to expand their studies during their residency by joining either:

- The Clinician Investigator Program where they can complete an MSc; or
- The Clinician Scientist Training Program where they can complete a PhD

If the resident qualifies to join the program, we provide them with a leave of absence to complete it. We expect them to apply for awards, but the department will provide funds to make up any shortfall in their funding so they can maintain their resident income whilst completing their additional studies.

Residents who have, or are in the process of completing the program:



Year of completion	Name	Program
Currently completing	Irene Xie	Clinician Scientist Training Program (PhD)
Currently completing	Randy van Ommeren	Clinician Scientist Training Program (PhD)
2017	Rola Saleeb	Clinician Scientist Training Program (PhD)
2014	Andrew Gao	Clinician Investigator Program (MSc)
2014	Tao Wang	Clinician Investigator Program (MSc)

Anatomical Pathology

At a glance: Anatomical Pathology Residency Training Program

Program length	5 years
No. of residents currently enrolled	30
Program delivery	Series of mandatory and elective rotations as well as three hours/week didactic sessions
Evaluation methods	Direct observation, written, slide and oral exams, resident case logs
Program Director	Dr. Susan Done

Our highly sought-after Anatomical Pathology Residency Training Program provides a broad experience with many opportunities for our residents.

Anatomical Pathology definition

“Anatomical Pathology is the branch of medicine concerned with the study of the morphologic and molecular aspects of disease. It includes the domains of surgical pathology, autopsy pathology, cytopathology, and molecular pathology, and it is essential to patient care because it provides a foundation on which clinical decisions are made.”

– The Royal College of Physicians and Surgeons of Canada

6 Residency Training Programs

Ours is the largest Anatomical Pathology residency program in Canada in number of teaching staff, research productivity, hospital facilities and patient volume. These resources offer an unequalled opportunity for Anatomical Pathology residency training.

Our large research establishment and strong academic program provide a supportive environment for learning and enquiry in all aspects of Anatomical Pathology, as well as the diversity of experience offered across our teaching sites.

Program learning outcomes

Our Anatomical Pathology program provides:

- Training that covers the full curriculum described by the Royal College of Physicians and Surgeons of Canada
- An opportunity for our residents to be the best pathologist that they can be
- A large volume of cases that ranges in complexity up to quaternary level and interaction with a large diverse group of faculty
- The opportunity to see many different practice types to help with career planning
- Residents have access to electronic resources through the hospitals and the University of Toronto library system
- A safe, supportive environment with attention given to trainee wellness

Program delivery and assessment

The program is based around the main academic centres in Toronto where over 120 staff anatomical pathologists at multiple sites are involved in resident education.

- Mount Sinai Hospital (MSH)
- Sunnybrook Health Sciences Centre (SHSC)
- St. Michael's Hospital – Unity Health (SMH)
- The Hospital for Sick Children (SickKids)
- The Forensic Services and Coroner's Complex at Downsview (PFPU)
- University Health Network (UHN)

As well as Community Hospitals including Michael Garron, Trillium Health Partners – Credit Valley, North York General Hospital, Lakeridge Health and Unity Health – St Joseph's Health Centre.

Our program is largely case-based and learning occurs around interactions with faculty.

There are several components to our resident's learning which include:

- a weekly Academic Half Day (AHD) on Monday afternoons
- a journal club run by the residents once a month
- "unknown slide" sessions at each of our main sites
- oral presentation by resident at "omics" journal club at Mount Sinai.

We are currently in transition to the competency by design model of residency education (CBD) and currently have two distinct programs:

1. Time based – exam at end of Year 5
2. CBD – exam at end of Year 4 so less flexibility for trainees with their rotations up to that point. Year 5 transition to practice (TTP) will provide flexibility for this group.

Quality of the program



In a sample of 86 of our AP alumni:

- 61** are working in a hospital or health centre in Ontario
- 8** are working in a hospital or health centre elsewhere in Canada
- 5** work for a government body in Ontario
- 7** are continuing their training
- 5** are outside Canada, roles unknown



We use several methods to measure the success of our program:

- United States and Canadian Academy of Pathology (USCAP) presentations
- Results of the semiannual exam
- Resident participation in the LMP Research Conference
- Effect of COVID on learning environment survey with follow-up
- Learner mistreatment survey
- Pass rate at the RCPSC exam
- The numbers of full RCPSC accreditations until 2028

The Residency Program Committee (RPC)

Our Residency Program Committee (RPC) meets quarterly and reviews strengths or areas for improvement in the program. If an issue requires more urgent attention, the committee members are contacted electronically.

The Site Directors at each affiliated hospital present reviews on a rotational basis at the RPC. They present a summary of rotation evaluations over the past year and a summary of the written comments as provided by the Postgraduate Web Registration System (POWER). These reports address the issues of individual rotations and resources. The RPC then discusses any proposed changes.

The RPC has a process to gather feedback directly from the resident representatives. At each meeting the resident report is a standing item on the agenda and resident feedback is used to inform program improvements and to monitor the impact of implemented action plans.

The Resident's Report is the first item on all agendas of the RPC and the Chief Resident or Junior Resident representative will raise any other issues as they pertain to rotations or resources of the formal teaching program.

The formal curriculum is reviewed annually by the person in charge of the academic half day (AHD) who sits on the RPC together with the Chief Resident, the Program Director and the Postgraduate Coordinator.

Responding to resident feedback

Feedback from residents is highly valued and either solicited from the Chief Resident and Junior Representative or obtained by survey.

Residents participate actively in reviews either through their representatives on the RPC or by direct polling of proposed changes. Generally, the RPC representatives are asked to gather greater resident feedback on proposals prior to final development or implementation. The resident report section of the RPC agenda is first up and generally occupies much of the meeting time and is the source of much of the changes that occur.

Some feedback we have received and acted upon is below.

Feedback on autopsy pathology

Resident and faculty comments at the RPC (Site review, 2016) brought up the issue of where junior residents get the best experience in learning autopsy pathology; the Provincial Forensic Pathology Unit (PFPU) or at University Health Network-Toronto General Hospital (UHN-TGH).

What we did: We asked the residents to complete a survey on the topic and they indicated:

- the best hands-on experience was at TGH
- the number of cases was greater at the PFPU
- the nature of the cases at the PFPU make them more appropriate for senior residents

We therefore changed the curriculum to two months at UHN-TGH as a junior and two months at the PFPU as a more senior resident.

Feedback on molecular pathology rotations

Regular rotation reviews identified recurrent concerns about the molecular pathology rotation (Rotation review, 2015). Reviews were critical of the heavy reliance on the technical aspects of training and limited access to clinical staff.

What we did: We gave the rotation to a new staff director who completely re-worked the rotation making it more clinical in nature and, so far, has received positive reviews about his engagement with residents.

Feedback on the academic half-day

Resident feedback on the academic half-day (Program review, 2014). Our residents felt the training was too didactic and wanted more hands-on, practical approaches to learning.

6 Residency Training Programs

What we did: We changed the format to a more practical case-based model with provision of appropriate reading materials.

Adapting to meet changing needs of the profession

Pathology is adapting to, and embracing new technologies, such as the clinical introduction of telepathology, digital consultations, and tissue archival issues. This is reflected in changes such as including digital slides in the RCPSC exam.

In response to this growing need from the profession, and from resident feedback, we:

- digitized our in-training examinations (practical and oral components)
- developed a digital learning library (web-based) (Curriculum review, 2016). This was also in response to increasing resident requests (Resident Reports, RPC)
- enhancing AI content in curriculum through T-CAIREM.

Enhancing the curriculum

In addition to adapting to the changing needs of the profession, we have enhanced our curriculum, such as:

- Creating the “Transition to Discipline” course for AP residents (known as ‘Bootcamp’). This award-winning course brings new residents together for four weeks at the start of their residency and gives them a crash course in pathology and how to work in a clinical laboratory. This not only fills any knowledge gap, but also allows the residents to build community which is normally a challenge when faced with rotations through multiple training sites.
- We have expanded mentorship and teaching opportunities. Current residents spend time interacting with medical (MD) students through initiatives such as the Laboratory Medicine Interest Group (LMIG) where our residents run a popular ‘case of the month’ for the students (See Undergraduate Medical Education, [page 150](#) for more).
- Moving the AP bi-annual exam from a paper-based, in person exam, to fully online
- Redeveloping the curriculum due to the implementation of CBD.

Carlo Hojilla uses his own experience as a resident to create an award-winning course



Traditionally, undergraduate and medical students get exposed to very little pathology teaching so when they arrive in a residency program, they often have large gaps in their knowledge. With constant rotations throughout our hospital network, they also struggle to build relationships and community. Dr. Hojilla completed our AP residency and used his experiences to create a bootcamp aimed at filling knowledge gaps and teaching the basics of pathology before entering into the diagnostic realm, and helping residents get to know each other. The course has won awards and is being rolled out nationally.

[Read more about Carlo and why he created ‘Bootcamp’](#)



Increasing the pool of candidates

To help widen the pool of candidates for Anatomical Pathology, we conduct the below activities:

- Recently created a research section on our website which lists and celebrates research conducted by our current residents, including short videos made by the residents describing particular areas of their research.
- Standardized CaRMS interviews following Best Practices in Application and Selection (BPAS) from PGME.
- Our faculty offer a “Day in the life of a pathologist” shadowing opportunities for medical students (See Undergraduate Medical Education, [page 150](#) for more).
- Developed a pathology interest group for medical students
- Offer monthly interesting pathology case of the month for medical students
- See an autopsy at the Forensics facility

Wellness

The wellness of our residents is of high priority and they are active in our Wellness, Inclusion, Diversity and Equity (WIDE) committee, and similar initiatives in hospital sites.

To help support our residents, particularly during the COVID-19 pandemic, we:

- Supplied them with ‘Tech packages’ which included webcams, headphones and microscope cameras.
- Shifted case reviews online with faculty
- To ensure our residents could carry on learning through their academic half days during the pandemic, the Chief Resident created an online module to replace it which won two awards in U of T.
- Held regular virtual check-in meetings.

Susan Armstrong recognized for residents’ online education during the pandemic



Dr. Susan Armstrong is the current Chief Resident in our AP program. She has various teaching responsibilities, but her proactive approach to changing residents’ education to an online format during COVID-19 has resulted in her being awarded The Avrum Gottlieb Award for Curriculum Development and Teaching Excellence in Training by LMP and the PARO Trust Fund’s Resident Teaching Award from the University of Toronto.

[Read more about Susan and why she received these awards](#)

Response to 2013 External Review

Overall, the Review found our Residency Training Programs “Well-structured and appropriate”.

They highlighted only one issue around the availability of autopsy resources for our Anatomical Pathology residents, which was “especially important as there is reduced number of hospital autopsies combined with rotation of off-service residents and residency program in forensic pathology”.

Based on feedback, we adjusted how our residents spend time completing autopsies at the Provincial Forensic Pathology Unit (PFPU) and at University Health Network-Toronto General Hospital (UHN-TGH), see [page 107](#).

Ontario is home to the largest death investigation system in North America, and the majority of the autopsies in the province are performed in Toronto at the Provincial Forensic Pathology Unit (PFPU), which our residents have access to. Other programs across the country have based their curriculum on ours.

Hematological Pathology

At a glance: Hematological Pathology Residency Training Program

Program length	4 years
No. of residents currently enrolled	2
Program delivery	Series of mandatory and elective rotations as well as weekly didactic sessions
Evaluation methods	Direct observation, written, slide and oral exams
Program Director	Dr. David Barth

Our Hematological Pathology training program will ensure that specialists in Hematological Pathology have the confidence to act as consultants to clinicians with respect to appropriate investigation, diagnosis and monitoring of disorders of blood cells, bone marrow, lymph nodes, spleen, and hemostasis.

We expect our residents to be competent in all aspects of organizing and running a transfusion medicine service as well as to be competent in laboratory management issues of blood and blood product procurement and issuing.

Program learning outcomes

Upon completion of training, we expect our residents to:

- be a competent specialist in Hematological Pathology capable of assuming a consultant's role in the specialty.
- acquire a working knowledge of the theoretical basis of the specialty, including its foundations in science and research, as it applies to medical practice.
- have a broad experience in both clinical and laboratory practice.
- understand the needs of laboratory Hematology in an adult, pediatric and community setting.

Program delivery and assessment

Our Hematological Pathology program has staff and facilities across a number of hospital sites, however the training program operates as a single unit. The facilities provided in the four major teaching hospitals are extensive and the volume in the combined hospitals is larger than any other centre in Canada.

Teachings sites include:

- St. Joseph's Health Centre
- LifeLabs
- Mount Sinai Hospital (MSH)
- St. Michael's Hospital – Unity Health (SMH)
- Michael Garron Hospital
- The Hospital for Sick Children (SickKids)
- Sunnybrook Health Sciences Centre (SHSC)
- Trillium Health Partners
- University Health Network (UHN)

Residents have access to electronic resources through the hospitals and the U of T library system. We deliver formal instruction through a weekly academic half-day with a curriculum covering the full range of topics in hematological pathology in addition to relevant aspects of the non-medical expert CanMEDS roles.

The four-year program is structured to meet the requirements of the Royal College of Physicians and Surgeons of Canada.



Currently, the format of the PGY-1 year is based on educational objectives of the program.

- Seven blocks of clinical training
- Allows the new hematopathology resident to build upon knowledge and skills gained in medical school and the clinical clerkship.
- Intended to give the resident a broad-based exposure in preparation for specific specialty training in hematopathology and for the MCCQE Part II examination.

The following two and a half years are spent in core laboratory hematology training with rotations in quantitative hematology, morphological evaluation of blood films, bone marrows and lymph nodes, flow cytometry, investigation of thrombosis and hemostatic disorders, transfusion medicine, pediatric hematology, molecular hematology and cytogenetics and laboratory management.

During the final year the resident is encouraged to undertake a research project and pursue advanced training in a particular branch of hematopathology.

Starting in July, 2022, all PGY-1 residents in Hematological Pathology residency training programs throughout Canada will implement the Competence By Design (CBD) curriculum format.

- The first stage for residents is Transition to Discipline (TTD), which will include an orientation Hematological Pathology.
- Foundations of Discipline (FOD), the second stage of the continuum of residency education, is when the basics are taught, learned, assessed, and demonstrated.
- Core of Discipline (COD) is the third stage of the continuum of residency education and is the longest stage of training. During this stage, the resident will complete various Hematological Pathology rotations to gain competence in the diagnosis and monitoring of disorders of blood cells, bone marrow, lymph nodes, spleen and hemostasis. It is anticipated that in the future the specialty exam will be administered near the end of the Core stage.
- The fourth and final stage of residency education is Transition to Practice (TTP), which focuses on ensuring residents' confidence and competence to practice within their discipline. This stage occurs after the completion of the Royal College exams to allow the resident some flexibility to complete research projects and rotations of particular interest.

We expect all residents to complete a scholarly project during the course of their residency and present their findings locally at the departmental Research Day and nationally or internationally at scientific meetings.

The residency program is led by the Hematological Pathology Residency Program Committee, which is chaired by the Program Director and meets quarterly to review and administer the various aspects of the residency program. Committee members include site directors of the hematological pathology training sites, representation from Transfusion Medicine and Hemostasis and Thrombosis as well as resident wellness and research coordinators.

Quality of the program



In a sample of 9 of our HP alumni:

- 4** are working in a hospital or health centre in Ontario
- 5** are working in a hospital or health centre elsewhere in Canada

Our graduates

- 2 Canadian graduates all successfully secured staff positions in Canada, both retained locally in Ontario.
- 5 International graduates all obtained staff positions in Canada (3 British Columbia, 1 New Brunswick, 1 Ontario).
- 1 Sponsored resident is currently undertaking a fellowship in Lymphoma.

Our faculty

Our faculty teaching the program include internationally recognized experts in the fields of Hematological Pathology, including

- 3 full Professors
- 3 Associate Professors
- 12 Assistant Professors.



Quality enhancements since 2013

Since 2013, we have:

- formalized a research program for residents which includes a faculty research lead and an up-to-date research staff list of ongoing and future projects.
- formalized a mentorship program which provides residents with discussion around practical issues of day-to-day residency, areas of interest in Hematological Pathology, research advice, career planning, problems/issues amongst others. All residents have the option of choosing a mentor or having one chosen for them.
- Introduced Transfusion Medicine and Hemostasis and Thrombosis representation on the residency program committee which allows direct and timely feedback on these important, mandatory rotations.
- revised the time-based curriculum to “better show” graded responsibility of residents from year to year. We revised goals and objectives as well as in-training evaluation reports. This now allows the evaluation of resident’s morphology abilities in light of current level of training. It also differentiates the expectations of the resident and teacher for different years of training, so that there is a difference in assessment of the residents in the morphology rotation at different PG years. The revised curriculum now prevents significant overlap in what is taught in morphology rotations in the different PG years to ensure incremental increase in diagnostic complexity which will increase knowledge and skill over time.

Medical Microbiology

At a glance: Medical Microbiology Residency Training Program

Program length	5 years
No. of residents currently enrolled	5
Program delivery	Series of mandatory and elective rotations as well as weekly didactic sessions
Evaluation methods	Direct observation, written, slide and oral exams, resident portfolio
Program Director	Dr. Tony Mazzulli



According to the Royal College definition, Medical Microbiology is a branch of laboratory and clinical medicine concerned primarily with the diagnosis, treatment, and prevention of infectious diseases.

The specialty of Medical Microbiology consists of five general spheres of activity:

1. Scientific development, and administrative and clinical direction of a microbiology laboratory;
2. Clinical consultations, in both inpatient and outpatient settings, on the investigation, diagnosis, treatment, and prevention of infectious diseases;
3. Infection prevention and control;
4. Antibiotic stewardship; and
5. The epidemiology of communicable diseases.

Our program aims to train competent specialists in medical microbiology, capable of assuming a consultant's role in the specialty.

Program learning outcomes

By the completion of their training, our residents should be competent to practice medical microbiology in the following key areas:

1. Scientific and administrative direction of a clinical microbiology laboratory.
2. Creation and direction of a hospital infection control program.
3. Provision of clinical consultations on the investigation, diagnosis, and treatment of patient suffering from infectious diseases.
4. Public health and communicable disease epidemiology and prevention.
5. Creation and direction of an Antimicrobial Stewardship Program.

We expect our graduates to have a working knowledge of the theoretical basis of medical microbiology, including its foundations in basic medical sciences and research, and be competent in effective patient-centered care.

Program delivery and assessment

Medical Microbiology is a five-year program which will move to the Competence by Design model (CBD) over the next two years once the Royal College develops and distributes the relevant information to enable this. The program has already established a Competency Committee for the review and evaluation of each resident.

During 2020 and into 2021, we converted most teaching sessions into virtual presentations to allow for continuity of teaching. This will be maintained throughout the COVID-19 pandemic and will be re-evaluated by a committee consisting of trainees and faculty to determine whether these should continue or revert back to in-person sessions.

The outline below is our current time-based program curriculum and this will change once we implement CBD.

Year one (PGY-1)

This year consists of:

- Three months medical subspecialties
- Four months general internal medicine
- Two months infectious diseases
- One month general surgery
- One month surgical subspecialty

Years two to four (PGY-2–4)

The PGY-2 year is an additional year of clinical training with an emphasis on infectious diseases.

Our residents then complete two years (PGY-3 and 4) of core microbiology including training in the laboratories of adult hospitals, and at the Hospital for Sick Children.

This covers:

- bacteriology
- virology
- serology
- mycology
- molecular diagnostics

6 Residency Training Programs

They also receive training at the Public Health Laboratory in:

- parasitology
- mycology
- mycobacteriology
- reference microbiology

Year five (PGY-5)

The final year of training provides further experience in microbiology and gives residents a greater level of responsibility.

Quality improvement and patient safety

Each year residents participate in Co-Learning Curriculum in Quality Improvement program led by the Centre for Quality Improvement and Patient Safety at U of T.

Residents attend a series of workshops where they learn the essential components of a Quality Improvement (QI) initiative and then work together to develop and carry out a microbiology-specific QI project. There are one or two faculty members who provide guidance and serve as resources to the residents as they work through their project. Sometimes projects are developed in conjunction with the Infectious Diseases residents. Before the end of the academic year, the residents are expected to prepare a report and present their findings at one of the weekly rounds.

Neuropathology

At a glance: Neuropathology Residency Training Program

Program length	5 years
No. of residents currently enrolled	1
Program delivery	Series of mandatory and elective rotations as well as weekly didactic sessions
Evaluation methods	Direct observation, written, slide, and oral exams, resident portfolio
Program Director	Dr. Andrew Gao

Quality of the program

5
residents have completed the program since 2013

In a sample of 17 of our MM alumni:

- 9** are working in a hospital or health centre in Ontario
- 1** is working in a hospital or health centre elsewhere in Canada
- 5** work for a government body in Ontario
- 2** are working in hospitals outside Canada

We received full accreditation by the Royal College of Physicians and Surgeons of Canada (RCPSC) in December 2020 and our program was recognized for its Leading Practices and/or Innovations (LPI) offering a unique opportunity to trainees to develop their leadership, communication, and collaboration skills by exposing them to various hospital /departmental/ divisional committees.

We developed a 'Microbiology Bootcamp' early in the academic year to provide new incoming residents with an overall orientation to the program and information on the general basics of medical microbiology. This is led by senior residents with faculty oversight.

In 2015, Mount Sinai Hospital established the Donald E. Low Bursary which is open for residents to apply for funding to visit a local/national/international microbiology lab to learn a new skill or skills and then present the knowledge they have gained to the other trainees and faculty upon their return.



The overall objective of the neuropathology residency program is to train residents who will become competent specialists in Neuropathology, capable of assuming a consultant's role in the discipline.

Residents acquire detailed knowledge of neuropathology, including its basic science foundations and application to diagnostic practice. Residents gain competence in the pathological diagnosis of neurological disease using methods that include light microscopy, electron microscopy, immunohistochemistry, immunofluorescence, histochemistry, digital pathology, and molecular pathology.

We emphasize the correlation of neuropathological findings with clinical features, as well as the ability to communicate and collaborate with clinical colleagues on the choice of investigative procedures and their interpretation.

Our residents also acquire skills that will enable them to undertake laboratory management, supervision of neuropathology technical laboratories, and postgraduate continuing education.

Program learning outcomes

The clinical training experiences are defined by the Royal College of Physicians and Surgeons of Canada, and our program meets or exceeds those requirements.

PGY-1 residents complete a comprehensive clinical year focusing on the clinical neurosciences (neurology, neurosurgery, neuroradiology).

PGY-2 is devoted to core anatomical pathology, including autopsy and surgical pathology.

PGY-3–4 clinical rotations at the training sites spans the full spectrum of neuropathology, including:

- surgical neuropathology
- neuromuscular pathology
- neurodegenerative pathology
- autopsy neuropathology
- pediatric and perinatal neuropathology are covered in dedicated rotations at the Hospital for Sick Children and Mount Sinai Hospital
- forensic neuropathology has recently been added in the form of a two-block rotation at the Ontario Forensic Pathology Service.
- a longitudinal molecular pathology rotation is currently in development.

Program delivery and assessment

Our program is delivered across five academic hospitals encompassing the full range of adult, pediatric, and perinatal neuropathology:

- Mount Sinai Hospital (MSH)
- St. Michael's Hospital – Unity Health (SMH)
- Sunnybrook Health Sciences Centre (SHSC)
- The Hospital for Sick Children (SickKids)
- University Health Network (UHN)

We also use Trillium Health Partners, a community-affiliated academic centre with a neuropathology clinical service.

At every training site, a wide range of teaching materials is available for the resident to review in preparation for the Royal College exam. Residents take on increasing degrees of responsibility during their training and towards the end, function at the level of junior staff and represent neuropathology in interactions with clinical colleagues and laboratory technical staff.

- Residents have access to electronic resources through the hospitals and the University of Toronto library system.
- Formal instruction is delivered through a weekly academic half-day with a curriculum covering the full range of topics in diagnostic neuropathology in addition to relevant aspects of the non-medical expert CanMEDS roles.
- Regular review of unknown slides occurs at monthly city-wide rounds.

The neuropathology program will transition to competency by design (CBD) in July 2022.

Our faculty include internationally recognized experts in the fields of neuro-oncology and neurodegeneration, including:

- 3 full Professors
- 3 faculty members with recent promotions to Associate Professor.

The current faculty to resident ratio is 11:1.

Neuropathology Residency Program Committee

The residency program is led by the Neuropathology Residency Program Committee, which is chaired by the Program Director and meets quarterly to review and administer the various aspects of the residency program.

Committee members include site directors of the neuropathology training sites as well as resident wellness and research coordinators. The current Program Director is a former trainee of the program.

Quality of the program

Our residents



In a sample of 6 of our NP alumni:

- 2** are working in a hospital or health centre in Ontario
- 1** is working in a hospital or health centre elsewhere in Canada
- 3** have returned to other countries

Our residents have obtained numerous awards for academic performance, research, or teaching. Trainee awards include (2013 - present):

- 2 Trainees:** Mary Tom Award. Awarded for best clinical science presentation by a trainee at the Annual Meeting of Canadian Association of Neuropathologists
- 1 Trainee:** Morris Finlayson Award. Awarded for best basic science presentation by a trainee at the Annual Meeting of Canadian Association of Neuropathologists
- 1 Trainee:** O.T Bailey-Helena Riggs Award. Awarded for diagnostic case presentation by a trainee at the Annual Meeting of American Association of Neuropathologists
- 1 Trainee:** Conference Travel Award. Awarded to a trainee for travel to the Annual Meeting of American Association of Neuropathologists
- 1 Trainee:** PARO Resident Teaching Award. Awarded to Ontario residents who have provided outstanding clinical teaching experiences to junior house staff and clinical clerks
- 1 Trainee:** Canada Graduate Scholarship-Master's Program Award. Awarded for graduate research financial support by Canadian Institutes of Health Research
- 1 Trainee:** University of Toronto Fellowship. Awarded for graduate research financial support by the Dept. of Laboratory Medicine and Pathobiology, University of Toronto
- 2 Trainees:** Hold 'Em Oncology Fellowship. Awarded to residents or clinical fellows pursuing cancer research
- 1 Trainee:** Vanier Graduate Scholarship. These prestigious scholarships are limited in number and are awarded to highly selected students who demonstrate leadership skills and a high standard of scholarly achievement in graduate studies in the social sciences and humanities, natural sciences and/or engineering and health.

Scholarly activity is required during neuropathology residency training and our trainees have demonstrated exemplary productivity during the past eight years.

One trainee completed the Clinician Investigator Program (CIP) during their residency (MSc) and one trainee is currently enrolled in the Clinician-Scientist Training Program (PhD candidate).



Quality enhancements

Forensic neuropathology

The neuropathology program, in collaboration with the Ontario Forensic Pathology Service, introduced a forensic neuropathology clinical rotation in 2017, which takes place at the Coroners' Building.

Our senior resident at the time was the first to rotate through this service with the objectives of establishing a solid foundation in forensic neuropathology and gaining exposure to medico-legal autopsies that necessarily take place outside of the hospital setting.

This fulfilled an unmet need identified in our program as adult forensic autopsies no longer took place within the academic hospital system. This rotation also provided the opportunity to become familiar with aspects of the legal system, such as interactions with law enforcement, legal counsel, and the court system.

Molecular neuropathology

Currently, we are in the process of creating a longitudinal molecular neuropathology rotation at the Hospital for Sick Children in anticipation of the significant molecular advances in our field. The Hospital for Sick Children is ideally suited for this rotation given the presence of internationally recognized expertise in this field, its challenging case volume, and the availability of technologies such as next-generation sequencing, chromosomal microarrays, nanoString, ddPCR, and DNA methylome profiling. This will be expanded to include perinatal and adult neuropathology at other hospital sites.

Bootcamp

Our new incoming residents in Neuropathology join the Anatomical Pathology Bootcamp (see [page 108](#)). This provides a basic introduction to the processes and techniques common to all pathology specialties so that there is a common base on which to build specialized knowledge and helps our residents build a network.

Digital pathology

Digital pathology has recently become an important tool in pathology education. Our program has been highly involved in LMP's Digital Laboratory Medicine platform. Our previous Chief Resident contributed nearly 80 cases to the library and this resource has been used in unknown slide sessions and informal teaching sessions for residents in the neuropathology and anatomical pathology programs.

Similarly, the National Neuropathology Lecture Series was instituted by a member of our faculty and is now hosted on the website of the Canadian Association of Neuropathologists. This lecture series, now totaling 17 lectures, has become an invaluable resource, not only for our trainees, but also the neuropathology community at large. We have recently expanded our virtual offerings to provide lecture series on [degenerative neuropathology](#) (Dr. Gabor Kovacs).

Increasing the pool of candidates

In 2019 we began to consider international medical graduates (IMGs) for CaRMS positions and the number of applicants rose significantly by about a factor of 10. This change has created a much larger pool of potential applicants to our program and increased our ability to select the top-tier candidates for interview and matriculation. We also received approval to offer a combined AP-NP residency program from our PGME office. Ultimately, we expect this will invigorate our program with candidates from a diverse range of backgrounds.

Forensic Pathology

At a glance: Forensic Pathology Residency Training Program	
Program length	1 year
No. of residents currently enrolled	2
Program delivery	Series of mandatory and elective rotations as well as weekly didactic sessions
Evaluation methods	Direct observation, written, slide and oral exams, resident portfolio
Program Director	Dr. Jayantha Herath

Forensic Pathology is a subspecialty of Anatomical Pathology and General Pathology. It applies basic pathologic principles and methodologies of these two specialties to support the medico-legal and judicial systems in determining causes and manners of death, supporting the investigation of circumstances surrounding deaths, and assisting in the interpretation of post-mortem findings of medico-legal significance. These principles also can apply to injuries of the living.

Our program of postgraduate training in Forensic Pathology is in partnership with the Ontario Forensic Pathology Service (OFPS). It is funded by the Ministry of Health and administered by LMP and is the first training

program in Canada leading to certification in forensic pathology by the Royal College of Physicians and Surgeons of Canada (RCPSC).

Since 2007 we have partnered with the Provincial Forensic Pathology Unit (PFPU) of the OFPS to train the next generation of forensic pathologists for Canada and the world. The OFPS is committed to the virtuous cycle of ‘service, research and teaching’ as the primary driver for advancing and sustaining the profession of forensic pathology. To this end, the University of Toronto and OFPS have become leaders in promotion and training of forensic pathology and forensic medicine practitioners in Canada and internationally to support public death investigations, as well as criminal justice and human rights.

Admission requirements

Our Forensic Pathology residents are primarily graduates of Canadian Anatomical Pathology training programs. International applicants tend to be clinical fellows with variable backgrounds in pathology and forensic medicine and join our Fellowship program, outlined in Fellowship Training Programs, [page 142](#).

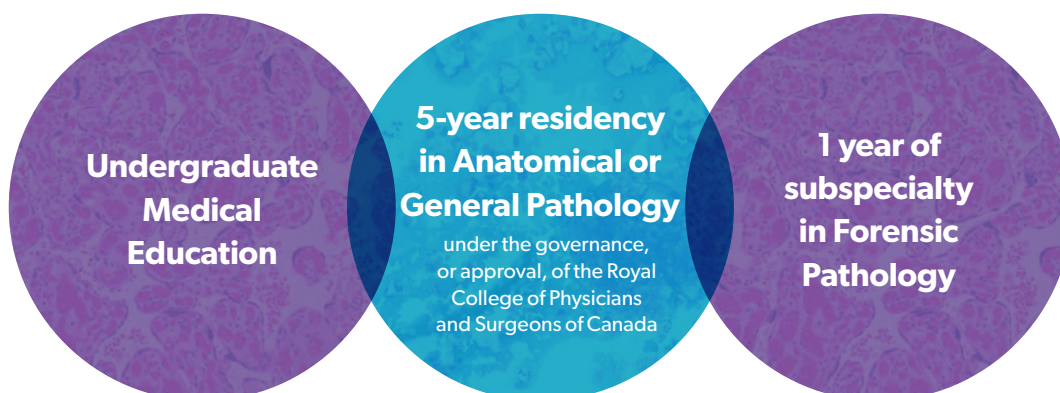



Program learning outcomes

The goal of our program is to:

- graduate competent forensic pathologists
- align the forensic pathology training curriculum with societal needs and expectations
- optimize death investigation and justice administration.



The Toronto Forensic Pathology unit moved to a state-of-the-art building named the Forensic Services and Coroners Complex in 2013. The Office of the Chief Coroner, the Ontario Forensic Pathology Service, Ontario Fire Marshall and the Centre of Forensic Sciences are all in the same facility. Housing the four agencies in one site has led to operational efficiencies. The new facility allows staff, who work closely during investigations, to collaborate and share resources.

The Forensic Services and Coroners Complex at glance

550,000 sq ft

15 autopsy stations

Dedicated teaching room

CT scanner

MRI scanner

Digital x-ray facilities

Faxitrone

In-house histology lab

Program delivery and assessment

Our program is accredited by the RCPSC and residents are eligible to sit the RCPSC sub-specialty examination in Forensic Pathology.

The training takes place at the PFPU at the Forensic Services and Coroners Complex in Toronto. The forensic unit in Toronto performs approximately 6,500 autopsies per year and provide excellent basic training in autopsy techniques and can provide a very good volume of cases for residency and fellowship training.

Competence by Design (CBD) in Forensic Pathology

We were the first to implement CBD in Forensic Pathology in Canada, having introduced this model in 2018 to train forensic pathology residents and fellows. Residents are assessed more frequently, with a preference for direct observation.

Feedback is more timely, frequent, and constructive, and therefore helpful in the growth and progression of the resident.

6 Residency Training Programs

The Competence Continuum reflects the developmental stages of professional practice ranging from:

- Stage one: Transition to Discipline (TTD), spread through one block
- Stage two: Foundation of Discipline (FOD), spread through three blocks
- Stage three: Core of Discipline (COD), consists of six blocks
- Stage four: Transition to Practice (TTP), consists of three blocks.

In each stage, there are specific milestones a resident is expected to demonstrate. The duration (the number of blocks) for each stage is determined by our CBD committee.

Entrustable Professional Activities (EPAs)

EPAs are tasks in the clinical setting that may be delegated to a resident by their supervisor once sufficient competence has been demonstrated. Typically, each EPA integrates multiple milestones, and it is generally used for overall assessment.

Learners, teachers, and assessors are focused on concrete critical clinical activities that provide insight into the residents' development, progress, and proficiency. Each day, faculty members decide which medico-legal problems they will assign to which residents during morning rounds. EPAs aim to provide some consistency in when, how, and where specific activities of forensic pathology are taught, learned, and assessed.

Required Training Experiences (RTE)

RTE is a new Royal College document that includes the eligibility requirements for the discipline and the training experiences required or recommended for each of the four stages of the residency education competence continuum.

Rounds and didactic sessions

Forensic Pathology conducts multiple teaching/learning activities such as:

- lectures
- morning and afternoon rounds
- small group discussions
- microscopy sessions
- difficult case rounds
- journal clubs
- group learning activities
- a regular academic half-day per week.

CBD Committee review and progress to the next stage

At regular intervals during each stage of training, a competence committee reviews the documented observations and other assessment data in the electronic portfolio and provides the recommendation on the resident's progression to the next stage of training.

After the CBD committee decision, the resident is promoted to the next stage to tackle a new competency set.

A copy of the CBD committee decision report is also sent to the individual resident. The Royal College exam is only one of many assessment points. At this moment, the Royal College exam is held in the fall, three months after completing the final CBD stage.

Assessments and promotion to the next stage

The assessments are robust and multifaceted. The conclusions drawn from the formative assessments in CBD is important for both the learner and the assessor. The assessment methods are listed in every stage below. We complete almost all assessments electronically.

The plan provides an accurate picture of a resident's progress on the competence continuum. After each procedure (autopsy, dissection, reporting, scene assessment, learning activity, etc.), the resident initiates an assessment and sends it to the assessor electronically via Elentra (see [page 103](#) for more information on Elentra)

Promotion is the confirmation of resident advancement from one stage to the next stage (e.g., from FOD to COD) within a residency training program.



The four CBD Stages of Forensic Pathology Training Program

1. Transition to Discipline Stage (TTD) – 1 block

This includes an orientation to forensic pathology and demonstration of readiness for autonomy and taking responsibility for routine uncomplicated medico-legal cases. During the TTD stage, they learn to apply knowledge of medicine, basic medical sciences, and pathology into the death investigation system and identify any significant gaps in knowledge.

- **Focus:** on orientating new residents with diverse backgrounds and training to the roles within the interprofessional team; on institutional policies and regulations related to practicing forensic pathology, including health and safety policies and legal and regulatory frameworks.
- **Assessing skills:** on performing pre-autopsy assessments, demonstrating procedural abilities, and writing autopsy reports.
- **Required training experiences included in this rotation:** Case assignments and teaching rounds – morning, autopsy suite engagement, afternoon closing rounds, AHD, journal club, on-call shadowing.
- **Assessments:** ITAR, Slide test, Procedure Log, daily assessments after performing an autopsy.
- **Transition to Discipline EPA List:** performing pre-autopsy assessments, performing autopsies, and preparing autopsy reports in uncomplicated cases.

2. Foundations of Discipline Stage (FOD) – 3 blocks

Residents are taught the basics, including the most common and frequent medico-legal situations of the specialty.

- **Focus:** on developing the skills to perform a routine autopsy and communicate findings and opinions to stakeholders. The resident performs these tasks in death investigations, under clinical supervision, including the appropriate stewardship of time and resources. For routine cases, trainees are required to review and interpret information from death scenes and perform forensic pathology examinations, including forensic autopsies and select appropriate dissections. They will learn to use the information gathered to formulate opinions and an autopsy report on routine death investigations findings. Residents also gain

additional experience in more complex pediatric cases or those considered to be suspicious in this stage.

- **Required training experiences included in this rotation:** Case assignments and teaching rounds – morning, scene assessment (remote with paperwork, images, etc.), autopsy suite, afternoon closing rounds, AHD, journal club, on-call shadowing.
- **Assessments:** ITAR, Procedure log, Scene assessment, assessment during rounds.
- **Foundations of Discipline EPA List:** interpreting the circumstances of the case; performing dissections including open the calvarium, layered anterior neck with tongue removal, layered anterior torso, spinal cord removal, evaluation of cardiac conduction system, removal of testes; performing forensic autopsies of routine cases (adult and older child, nonsuspicious injuries, suicide, sudden natural deaths, intoxications, and complications of therapy); preparing forensic pathology reports, including opinions, of routine cases; delivering preliminary autopsy information to a variety of audiences; managing cases within the standards of timelines and resource stewardship.

3. The core of Discipline Stage (COD) – 6 blocks

In this stage, the medicolegal problems are increasingly complex, which is the essence of the discipline.

- **Focus:** to demonstrate the core skills of a forensic pathologist, not only demonstrating procedural and interpretive skills required for complex cases, dissections, and examinations, but also taking on more responsibility for safety, quality assurance, and teaching and supervising junior colleagues. Residents build on the previous stage's skills to provide case management of a death scene, manage a more extensive caseload, and participate in organ and tissue donation decisions. They learn how to perform a complex autopsy including homicides, criminally suspicious, complex medical and pediatric cases and communicate findings promptly.
- **Required training experiences included in this rotation:** Scene attendance, autopsy suite, case assignment, teaching rounds – morning, afternoon closing rounds, After-hours on-call coverage for forensic pathology service, AHD, Journal club, and on-call shadowing QA, scholarly project, supervision of technical staff and junior learners.
- **Assessments:** ITAR, Scholarly Activity, Teaching Rounds, Journal Club, Research, Procedure Log, slide test.

6 Residency Training Programs

- **Core of Discipline EPA List:** providing case management of the scene; confirming the identity of the deceased; performing special dissections including the face, eye, and middle ear, posterior neck, vertebral artery, layered posterior torso, perineum, and pelvic block, and layered extremity; performing forensic autopsies in pediatric cases; performing forensic autopsies of complex cases (homicides, criminally suspicious, complex medical, bodies recovered from hostile environments, exhumations, skeletal remains); formulating reports and documenting opinions of pediatric, and complex adult cases; facilitating organ and tissue donation; managing multiple victim fatalities; balancing clinical and other professional responsibilities; conducting a peer review of cases; providing clinical supervision for technical staff and junior learners, delivering formal teaching sessions, and completing a scholarly activity.

4. Transition to Practice Stage (TTP) – 3 blocks

This stage ensures residents' confidence and competence to practice within forensic pathology practice.

- **Focus:** on demonstrating the consolidation of skills required to perform death investigations for any case while managing a full forensic pathology caseload in addition to administering and managing all aspects of forensic pathology practice. Trainees are expected to demonstrate a contribution to their field as professionals, including participating in consultations for the criminal and civil justice system and leading initiatives to enhance Forensic Pathology. The resident performs routine and complex cases with minimal supervision, deliver findings to stakeholders and transition to the level of junior staff forensic pathologist.
- **Required training experiences included in this rotation:** Triage and scheduling of forensic pathology service activities, case assignment and teaching rounds, afternoon closing rounds, scene attendance, autopsy suite dissections, afterhours coverage of forensic pathology service, AHD, Journal Club, on-call shadowing, QA/QC activities of the unit, scholarly project, supervision of technical staff and junior learners

- **Assessments:** Case/procedure log, ITAR, Scholarly Activity, Teaching Rounds, preparing a career CV, Personal Learning Plan for the first three years of practice.
- **Transition to Practice EPA list:** performing death investigations; organizing the daily workload of the Forensic Pathology unit; managing the caseload of a forensic pathologist; consulting for the criminal and civil justice system; managing the physical and psychological safety of staff; developing a learning plan for first 3-5 years of practice and developing and maintaining a professional curriculum vitae.

In-Training Assessments (ITARs)

These are completed at the end of each stage to reflect whether the resident is met expectations of required EPAs, RTE, and CanMeds roles. When completing the ITAR, the resident is marked using a 5-point grading system to reflect his/her milestones during this stage. Marks and interpretations are given as follows:

- 1–2: Below expectations for the training level/ Performance below that of training level/ Does not know limits or ask for needed assistance/Not improving despite provided feedback.
- 3: Meets expectations for training level/Meets accepted performance for their training level, including common situations and presentations.
- 4–5: Exceeds expectations for training level/ Efficiently handles situations/Able to manage complex or complicated presentations/The excellence demonstrated consistently for training level.

Each resident should receive 3 or higher for a pass. Feedback comments are given to the residents, including strengths, actions, or areas for improvement and other comments.



Assessment tool key

The resident has to perform individual EPAs until they can perform each task independently (autonomy). Our CBD committee set a target of two successful entrustments that are necessary on each EPA. Each EPA is submitted through the Elenra electronic assessment system for the supervisor to assess.

Quality of the program



In a sample of 17 of our FP alumni:

- 4** are working in a hospital or health centre in Ontario
- 12** work for a government body in Ontario
- 1** works for a government body elsewhere in Canada

We share the lessons learned from our experiences on the program with the Forensic Pathology and medical education community with other programs, to enhance CBD training quality (e.g. Forensic Pathology in Manitoba, Alberta and Ottawa as well as other residency training programs at LMP).

We recruited two trainees who graduated by CBD and continue to guide them (competence continuum) as junior forensic pathologists.

Benefits of Competence by Design

We have found learners and trainers both benefit from CBD training due to:

- clear learning expectations for residents
- opportunities for feedback and coaching
- residents having more control of their learning
- helping prevent gaps in knowledge
- providing an opportunity to increase confidence and care
- promoting the use of feedback in lifelong learning.

The Program Director shared his experience with the Royal College and other Forensic Pathology training programs in Canada and internationally.

Strengths of the CBD program:

- The focus on outcomes.
- It accepts that each learner is unique and learns at his/her own pace.
- It promises greater accountability because the assessments are close to what would be done in real-practice situations.
- It allows individual trainees to advance through the CBD sooner than others.
- Residents can spend more time on electives or subspecialty training if they complete their training promptly.

It was more difficult for staff to adjust to the new changes than for new residents. As our program hosts residents from other residency programs and countries, the first two stages were different for each trainee.

Graduates since 2013

We follow up with our graduates and provide them job counseling and mentorship for the first three to five years of practice as junior forensic pathologists. We stay connected and support our graduates with continuing professional development and transition out of professional practice.

Studied	Name	Current Position
2020 Jul – Jun 2021	Dr. Daniel Smyk	PGY-6, subspecialty Forensic Pathology
2020 Jul – Jun 2021	Dr. Maliha Khara	PGY-6, subspecialty Forensic Pathology
2019 Jul – 2020 Jun	Dr. Alex John MacNeil	Forensic pathologist, Ontario Forensic Pathology Service.
2019 Jul – 2020 Jun	Dr. Linnea Duke	Accepted a new job as a Forensic pathologist at Forensic Pathology Unit Ottawa and University of Ottawa.
2018 July – 2019 Jun	Dr. Tyler Hickey	Forensic pathologist, Ontario Forensic Pathology Service.
Residents and fellows trained at our unit with traditional (Non-CBD) curriculum		
2017 Jul – 2018 Jun	Dr. Christopher Ball	Forensic pathologist, Ontario Forensic Pathology Service.
2016 Jul – 2017 Jun	Dr. Andrew Williams	Forensic pathologist, Ontario Forensic Pathology Service.
2015 Jul – 2016 Jun	Dr. Ingo von Both	Forensic pathologist, Ontario Forensic Pathology Service.
2015 Jul – 2016 June	Dr. Brett Danielson	Forensic pathologist, Sudbury Health Sciences Centre, Sudbury, ON
2014 Jul – 2015 June	Dr. Rebekah Jacques	Forensic pathologist, London Forensic Pathology Unit, ON
2014 Jul – 2015 June	Dr. Kona Williams	Forensic pathologist, Sudbury Regional Forensic Pathology Unit
2013 Jul – 2014 June	Dr. Maggie Bellis	Medical Manager/Forensic pathologist, Ontario Forensic Pathology Service
2013 Jul – 2014 Jun	Dr. Adriana Krizova	Staff pathologist, UHN, St. Michael's Hospital, Toronto

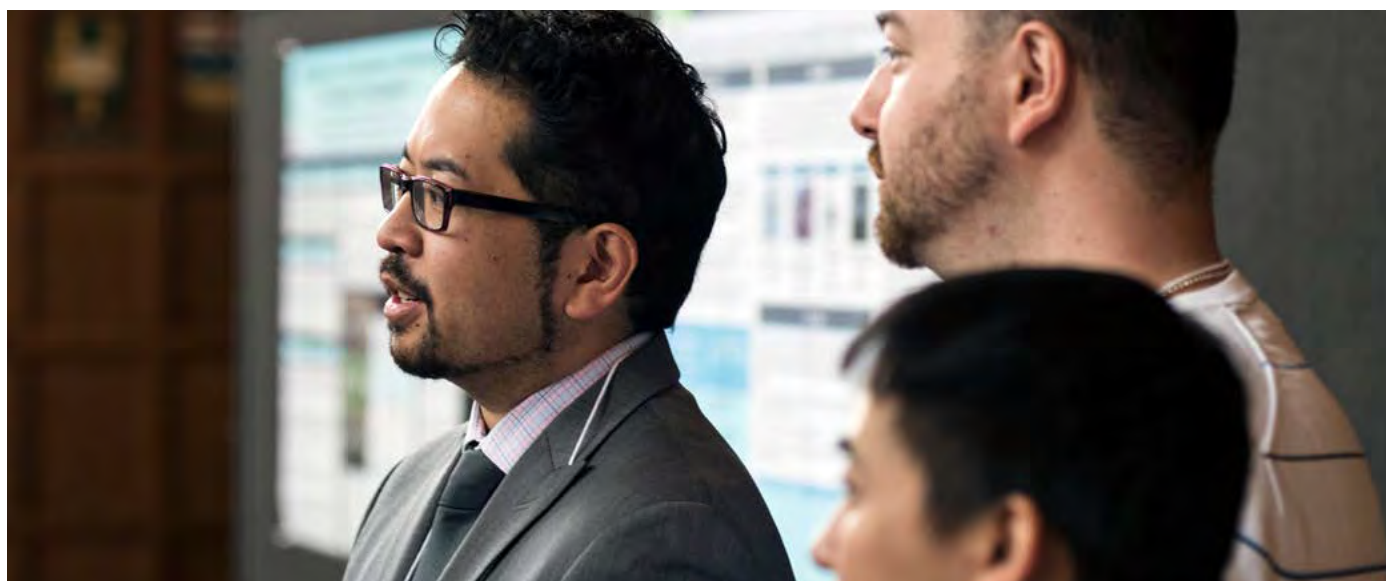



Clinical and Professional Education

Postdoctoral Diploma Programs

As the largest of its kind in Canada, our prestigious postdoctoral diploma programs allow trainees to pursue a career in: **Clinical Chemistry** or **Clinical Microbiology**.



Clinical Chemistry Postdoctoral Training Program

At a glance: Clinical Chemistry Postdoctoral Training Program

Program length	2 years
No. of diploma trainees currently enrolled	4
Program delivery	Hospital rotations, formal courses, tutorials and journal clubs
Evaluation methods	Direct Observation, oral exams, written exams and coursework
Program Co-Directors	Dr. Vathany Kulasingam and Dr. Paul Yip
Accreditation	Canadian Academy of Clinical Biochemistry, Commission on Accreditation in Clinical Chemistry

The Postdoctoral Training Program in Clinical Chemistry (Diploma Program), established in 1968, is a program for PhD graduates in biochemistry and related sciences to train as clinical chemists. The two-year program includes training in biochemistry, lab hematology and microbiology, to allow graduates to function in core laboratory settings. Candidates rotate through the clinical laboratories of several teaching hospitals affiliated with the University of Toronto.

The program meets the training requirements necessary to sit the written and oral examinations for certification set by the Canadian Academy for Clinical Biochemistry (CACB) and the American Board of Clinical Chemistry (ABCC).

Diploma trainees spend approximately half their time in a hospital laboratory and meet with their hospital supervisor weekly to discuss their progress. The remainder of the time is divided among formal coursework at the university, teaching sessions within hospital rotations, tutorials and journal club presentations.

Program learning outcomes

By the end of the first year, our diploma trainees must have:

- Completed the general clinical chemistry laboratory rotations based at Mount Sinai Hospital and University Health Network.
- Demonstrated a comprehensive, practical and theoretical knowledge of all the important routine procedures carried out in a modern clinical chemistry laboratory.
- Demonstrated an understanding of the operation, trouble-shooting and ordinary maintenance of all laboratory equipment, including automated instruments.
- Undertaken analytical, clinical or quality assessment projects.
- Successfully completed the Analytical Clinical Biochemistry course and Foundations of Medicine course.

By the end of the second year, they must have:

- Completed rotations through required hospital laboratories (paediatric chemistry laboratory, specialized laboratory services, clinical consultation service).
- Undertaken teaching assignments in clinical biochemistry as requested by their supervisors.
- Undertaken more extensive analytical, clinical or quality assessment projects, with the aim of presentation or publication.
- Undertaken specialization or research.
- Completed rotations through required hospital laboratories (hematology, immunology, microbiology, molecular biology) and community laboratories.
- Successful completion of the Biostatistics course and the AACC Clinical Laboratory Leadership and Management Certificate Program.

In all years, the diploma trainees must have:

- Completed required courses at a satisfactory academic level.
- Attended journal club and case presentation sessions.
- Attended seminars, conferences, rounds and lectures.
- Completed other required aspects of the program.

Admission requirements

We accept two PhDs into the Clinical Chemistry Program per year. There are up to four diploma trainees in the program at any one time.

Eligibility requirements

- PhD in Biochemistry or a related science (e.g. Biology, Chemistry, Immunology, Nutrition, Pharmacology, Physiology)
- PhD defense must be completed before the session start date of July 1
- Canadian citizen or status as landed immigrant
- Good communication skills – written and verbal
- A minimum of B+ in relevant courses and overall average during graduate studies

We will consider

- Strong background in chemistry or biochemistry with adequate background in the other disciplines
- Third-year level course in physiology or equivalent
- Research record, relevance to clinical chemistry
- Relevant experience in clinical chemistry, hematology, microbiology, molecular biology
- Commitment of the candidate to the field of clinical chemistry

Program delivery and assessment

The program is overseen by a Coordinating Committee, which meets quarterly. Representatives from across the hospital training sites make up the committee, as well as the Program Co-Directors, Postgraduate Education Officer, and the Departmental Chair (as ex-officio).

Committee Co-Chairs act as Program Co-Coordinators, and assign training sites to trainees each year, attempting to pair them with other trainees, including medical residents.

Hospital rotations

The Program Co-Directors, with the Program Coordinating Committee, plan the diploma trainees' rotations.

We consider the number of candidates, space in each centre, location of other trainees, and grouping of candidates.

Training in clinical chemistry consists of major (3–6 month) rotations in five main training hospitals, and shorter rotations and electives in other teaching sites.

Main training hospitals:

- Mount Sinai Hospital (MSH)
- Sunnybrook Health Sciences Centre (SHSC)
- St. Michael's Hospital – Unity Health (SMH)
- The Hospital for Sick Children (SickKids)
- University Health Network (UHN)



Expectations of hospital training sites:

- Emphasis on practical bench experience with exposure to instrumentation, methodology and safety. Trainees should be able to operate and troubleshoot standard equipment and perform all emergency tests and several specialized tests at the hospital.
- Exposure to clinical material (rounds, interesting cases, etc.).
- Opportunities for trainees to make oral presentations (e.g., seminar, question-and-answer session).
- Attendance at management sessions, involvement in problem solving.
- Completion of “Evaluation of Trainee by Hospital Supervisor” form by the last week of the rotation.
- The Canadian Academy of Clinical Biochemistry (CACB) Syllabus is the guide to the depth of knowledge required.

Laboratory management

We require our diploma trainees to participate in the online American Association for Clinical Chemistry (AACC) management course and obtain a certificate, which we fund.

Hospital sites also encourage trainees to attend management meetings, hold discussions with Chief Technologists, participate in the budget process, etc. Safety training is provided during hospital orientation before the start of rotations.

Course work

- ‘LMP1203H: Analytical Clinical Biochemistry’. Topics covered include spectroscopy, enzymology, separation methods, immunochemistry, electrochemistry, mass spectrometry, method validation and a variety of other analytical techniques that are commonly used in clinical laboratories.
- ‘MED100H: Introduction to Medicine’; ‘MED120H/130H: Concepts, Patients and Communities’. These courses are part of the Foundations Courses of the Medical School program. ‘Introduction to Medicine’ introduces students to key concepts and foundational knowledge including a broad introduction to the language and culture of medicine. ‘Concepts, Patients and Communities’ includes body systems (Microbiology, Immunology, Blood, Dermatology Cardiovascular, Respiratory, Endocrinology, Gastroenterology, and Genitourinary medicine) to provide trainees with Integration of

clinical manifestations, diagnosis, management and/or prevention of diseases of the systems with a focus on patient-centred clinical cases allowing students to develop clinical reasoning skills

- ‘MSC1090H: Introduction to Computational Biostatistics with R’. In this course data analysis techniques utilizing the R statistical language, are introduced and discussed, as well as the basics of programming. The goal of this course is to prepare trainees to perform scientific data analysis. They learn how to use statistical inference tools to gain insight into large and small data sets, as well as be exposed to innovative techniques and best practises to store, manage, and analyze (large) data. Topics include R programming, version control, automation, modular programming, and scientific visualization.

Journal Clubs and tutorials

We hold alternating tutorials and journal clubs covering topics relevant to clinical chemistry every week from September to June. Teaching faculty deliver tutorials and journal clubs are led, on a rotating basis, by the trainees, with a member from the teaching faculty acting as a mentor/discussant.

Research

In the latter half of their first year, and throughout their second year, we encourage our diploma trainees to participate in research projects under the supervision of their hospital site chemist. Graduates of the U of T program typically complete several projects and publish/present several manuscripts/abstracts during their two-year program. Our program is very academically oriented and encourages research as an important component of the clinical chemistry discipline.

Evaluation of trainees

During formal coursework:

- examination
- problem sets
- term papers
- oral examinations.

For apprenticeship work:

- diploma trainees are evaluated as “incomplete” for a weekly topic if knowledge is poor or assignments incomplete.

At the end of each hospital rotation:

- evaluated by their rotation supervisors through a formal assessment form.

The program holds individual training committee meetings with each candidate twice per year to review each candidate's progress. This is an informal oral exam to assess their readiness to sit the CACB certification exams.

Awards and funding

We award all diploma and residency trainees with an \$800 educational allowance per year.

Clinical Chemistry trainees are also eligible for an internal travel award (Allan Pollard Award), which is valued at \$1,000 (awarded to one trainee each year). They are also eligible, and frequently obtain, travel awards from the Canadian Society of Clinical Chemists (CSCC), Ontario Society of Clinical Chemists (OSCC), and AACC to attend a relevant clinical chemistry conference.

The Ontario Ministry of Health (MOH) issues six fellowships over two years, for the Province of Ontario (all training programs), to be shared between U of T (two fellowships per year) and McMaster University (one fellowship per year). The diploma trainees are then paid through the Toronto's Hospital Postgraduate Payroll Association (THPPA). Depending on availability, certain hospitals (HSC, UHN, SMH) may offer fellowships for a third year of training for interested / qualified graduates.

Quality of the program



The Program Co-Directors meet with trainees once a month, which serves to both ensure progress in the rotations and provides an opportunity for continuous feedback and improvement for the program.

- Diploma trainees have four semi-annual formal meetings with the training committee to review their progress over the course of their training and are asked to give feedback about the program (implemented in 2020).
- Courses and lecturers are evaluated by diploma trainees at the end of each course (sometimes mid-way through).
- Since July 2013, the Clinical Chemistry Trainees have been registered with the Postgraduate Medical Education Office (PGME), thus allowing the program to take advantage of the POWER On-line evaluation system to collect trainee evaluations and feedback regarding individual teachers and hospital rotations (see Residency Training Programs, [page 103](#) for more on POWER).

Changes we have made in response to feedback

Increasing salary

In response to feedback from multiple program accreditation visits, we increased the salary support on two occasions.

1. 2017 through re-distribution of MOH funding by reduction of one fellowship position, which raised the support for the remaining four positions over two years.
2. 2019 with distribution of funds supplemented through LMP which raised the salary so it was equivalent to the level of a first-year resident.

We established The Clinical Chemistry Training Program Fund in late 2013 to assist trainees with other costs such as travel/presentation at local/provincial meetings, attendance in online educational courses or webinars, etc.



Enhancing participation and feedback in Journal Clubs

We added video conferencing through WebEx in 2018. The regular audience now includes practicing Clinical Biochemists throughout Ontario and continues to present through Zoom with evaluations collected through SurveyMonkey.

We established a course website with Quercus (the University's learning management system) to provide a centralized document resource for candidates including access to policies, administrative forms, and library of past Journal Club presentations.

Elective rotations

We established a formalized elective rotation guideline and schedule in 2020 to provide a list of elective rotation options with learning objectives outlined for trainees in their second year to select from. We provided an opportunity to identify a new elective rotation and put in place instructions for obtaining approval from the Program Co-Directors.

Clinical Microbiology Postdoctoral Training Program

At a glance: Clinical Microbiology Postdoctoral Training Program	
Program length	3 years
No. of diploma trainees currently enrolled	3
Program delivery	Series of hospital-based rotations as well as didactic curriculum
Evaluation methods	Direct observation, written, practical and oral exams
Program Co-Directors	Dr. Tony Mazzulli
Accreditation	Canadian College for Microbiology (CCM)

The Postdoctoral Training Program in Clinical Microbiology is a program for PhD graduates in microbiology to train as clinical microbiologists, functioning in a diagnostic microbiology laboratory setting. The three-year program includes training in the microbiology laboratories of the teaching hospitals and the Ontario Public Health Labs, as well as didactic lectures and seminars.

The program meets the training requirements necessary to sit the certification examinations administered by the Canadian College of Microbiologists (CCM) as well as the American Board examinations.

Although we prepared for an accreditation visit by the Canadian College for Microbiology (CCM) in September 2020, this did not proceed due to the ongoing COVID-19 pandemic, and we are looking forward to rescheduling.

Program learning outcomes

During each rotation and throughout the program, diploma trainees are expected to meet the following objectives.

Microbiological knowledge

- **General knowledge of microbiology:** Trainee has sufficient knowledge of applied clinical microbiology to be a resource person in this area and to initiate new developments. Judgments and opinions are sound and troubleshooting is logical.
- **Technical bench skills:** Trainee can function without help performing routine procedures.
- **Knowledge of basic science:** Trainee has a reasonable knowledge of microbial physiology, pathogenic mechanisms, and host responses sufficient to explain the pathogenesis of common infectious diseases and is capable of filling gaps in knowledge where necessary. The trainee knows enough in this area to be able to assimilate advances in knowledge.
- **Knowledge of virology:** Trainee has a sound overall knowledge of the principles of virus/cell interaction and can apply these to the diagnosis and management of patients with virus diseases.
- **Parasitology:** Trainee has an adequate knowledge of microscopic morphology, life cycles and clinical manifestations of parasites, and usually makes a correct microscopic diagnosis.
- **Mycology:** Trainee is competent to obtain specimens and culture fungi, can prepare specimens for examination and is familiar with the appearance of most clinically important fungi. The trainee knows about and is competent to use current antifungal medications.
- **Infection control:** Trainee can make sensible decisions about infection control matters which are based on a thorough understanding of the principles of epidemiology and organism transmission. The trainee can write, articulate, and rationalize infection control policies. Faced with an outbreak the trainee can present a workable and defensible plan of action.

Clinical

- **Historical data (consults):** History usually complete and accurate; most vital information provided.
- **Diagnostic ability:** Most likely diagnosis is usually correct; differential diagnosis includes common problems.
- **Investigative planning:** Investigation plan appropriate, reflects current standards of practice; most tests logically ordered and interpreted correctly.
- **Therapy and prevention:** Readily applies principles of treatment and ongoing assessment; appropriately attends to preventative measures.
- **Judgement and decision making:** Uses good judgment resulting from evaluation of factors; makes good clinical decisions based on clinical information and general knowledge.

Administrative

- **Quality systems:** Understands and would be capable of developing good QA/CQI program.
- **Management ability:** Understands the legislative and financial aspects of management and will be a good administrator. The trainee will usually be prepared to make tough decisions.
- **Safety:** Understands the need for and respects safety precautions and is prepared to live by the same safety rules as other laboratory staff. Has a working knowledge of Workplace Hazardous Materials Information System (WHMIS).

Academic

- **Case presentation and teaching:** Trainee can make a well-organized, relevant, and appropriately directed presentation at rounds or in-service to a group of health care professionals, with well prepared and organized use of audiovisual aids.
- **Research and investigative:** Trainee can, with some advice, initiate and develop a project to the point of presentation at a national level and can conduct appropriate investigations to evaluate new methods.
- **Current awareness:** Trainee reads regularly and critically and is up to date in most important diagnostic and therapeutic matters. Aware of need for continual learning.



Personal qualities

- **Ethical standards:** The trainee is ethical and honest in dealings with patients, other health care professionals and commercial organizations.
- **Interpersonal skills:** The trainee is approachable, interacts well with colleagues, is not intimidating or offensive and will give help when asked. The trainee can explain and defend positions well to all categories of staff firmly, but without being offensive, arrogant, or patronizing. Functions well as a team member.
- **Relationship with technical staff:** The trainee relates well to technical staff who are willing to help with training in return for which the resident will help with the work and do some teaching. The trainee will sometimes, at the beginning of independent practice, need further direction and help with some management issues.
- **Self-assessment ability and insight:** Most of the time the trainee is aware of when help is needed and when it is not. Can handle criticism in an appropriate and professional manner.
- **Professionalism:** Arrives on time for meetings, does not forget to do things. Completes assigned tasks by deadline. Treats everyone with whom they interact with respect.

Admission requirements

We accept one new diploma trainee per year. At any given time, there are a maximum of three trainees in the program.

Applicants must have a PhD in microbiology or a related field prior to the start of their training which commences July 1 of each year. Individuals may apply during the final year of their PhD, but any offer of acceptance would be contingent on the individual successfully completing and defending their thesis prior to the start of the program. They must have maintained a B+ average in all coursework during their PhD program.

Program delivery and assessment

The Clinical Microbiology Training Program is closely aligned with the structure of the last three years of the Medical Microbiology Residency (see [page 112](#)).

The Program is administered by the Medical Microbiology Program Committee, consisting of representatives from each training site, trainee, Chair (ex officio), and the Program Director as Chair. The committee assists the Program Director in the planning, organizing and supervision of the program.

Rotations

Diploma trainees spend six months at each of the participating institutions' microbiology laboratories. Throughout each rotation, the staff microbiologist supervises the trainee. Residents have access to electronic resources through the hospitals and the University of Toronto library system. Practical bench teaching is conducted by the technologists at the bench-side. Each individual microbiology laboratory provides a schedule and rotation specific training objectives, the general components will include the following:

- Bench Rotations
- Laboratory management
- Technical manual
- Plate Rounds
- Seminars, Lectures and Rounds

Diploma trainees are expected to attend (and present on a rotating basis) at the Microbiology Lecture Series. In addition, each microbiology lab/hospital/public health lab will have its own set of weekly rounds/seminars/teaching sessions related to microbiology/infectious diseases which the trainees are expected to attend while on those specific rotations.

Evaluation of trainees

At the end of each hospital rotation, diploma trainees are evaluated by their rotation supervisors through POWER. The Program Director meets with each trainee at least annually. Practice oral, written, and practical exams are held annually.

Awards and funding

As mentioned in our Clinical Chemistry program, our diploma trainees are eligible for an \$800 educational allowance. Our Clinical Microbiology diploma trainees are also eligible for:

- The Norman Bethune Award which recognizes and encourages young, talented researchers on the threshold of their careers and is worth \$3,000. We encourage all our microbiology residents and diploma trainees to apply.

- Mount Sinai Hospital established the Donald E. Low Bursary in 2015 which our fellows are eligible for. They can apply for funding to visit a local/national/international microbiology lab to learn a new skill or skills and then present the knowledge they have gained to the other trainees and faculty upon their return.

The Ontario Ministry of Health issues fellowships, which are then paid through the Toronto Hospitals' Postgraduate Payroll Association (THPPA). These fellowships are for a 3-year period.

In addition to the Ministry funding, LMP offers a "top-up" to bring the level of funding for the trainee to the equivalent of a PGY-1 in the Medical Microbiology Training Program.

Spotlight on... Shawn Clark



Shawn Clark received the Norman Bethune Award at the LMP Annual Celebration of Excellence. He is in his second year of the Postdoctoral Training Program in Clinical Microbiology.

[Read a Q&A with Shawn](#)

Quality of the program



The Program Director meets with trainees annually to ensure progress in the rotations and provide an opportunity for continuous feedback and improvement for the program.

- A Diploma Trainee representative sits on the Medical Microbiology Program Committee to discuss issues of relevance to diploma trainees
- In Spring 2020, the diploma trainees were responsible for drafting an educational resource package for first year trainees giving them vital information ranging from core competencies, rotations, rounds and conference schedules, textbooks and educational resources, QI, IPAC, biosafety, stewardship and infectious diseases.
- Since July 2013, the Clinical Microbiology trainees have been registered with the Postgraduate Medical Education Office (PGME), thus allowing the program to take advantage of the POWER On-line evaluation system to collect trainee evaluations as well as trainee feedback regarding individual teachers and hospital rotations (see Residency Training Programs, [page 103](#) for more on POWER).



Clinical and Professional Education

Areas of Focused Competence

Areas of Focused Competence (AFC) are highly specialized disciplines of specialty medicine.

Our AFC programs provide subspecialty competency-based training for physicians who have achieved primary specialist certification in a primary discipline and are accredited by the Royal College of Physicians and Surgeons of Canada (RCPS).

Those who successfully complete our program can apply for a Diploma of the Royal College of Physicians and Surgeons of Canada (DRCPSC).

Our AFC Fellowship Programs have matured into well-structured, comprehensive and modern training programs that fulfill requirements set by the RCPS.

We offer two AFC programs:

- Cytopathology
- Transfusion Medicine



AFC Program in Cytopathology

At a glance: Cytopathology AFC

Program length	1 year
No. of fellows currently enrolled	1
Program delivery	Hospital-based rotations with graduated responsibility
Evaluation methods	In-training assessments, training portfolio
Program Co-Directors	Dr. Zeina Ghorab and Dr. Joerg Schwock
Accreditation	Royal College of Physicians and Surgeons of Canada

We established our AFC Cytopathology Fellowship Program in 2014 and were accredited through the RCPSC in the following year.

The program's goal is to provide dedicated subspecialty training in cytopathology for pathology residency graduates interested in pursuing a career in this area of diagnostic pathology.

The training provides the skills to contribute to, and oversee, the operations of a modern cytopathology laboratory in Canada at a medical, organization and procedural level. Since its inception, this program has gone through a complete five-year cycle of operations and received RCPSC re-accreditation after external review in 2020.

Future goals include:

- the transition to a fully electronic, real-time documentation of the training progress to facilitate evolution towards a competence-by-design structure
- a further development of the didactic resources to enhance and support the program curriculum and to offer greater flexibility to the fellow
- intensifying the exchange between active fellowship programs within Canada to forge a self-sustaining community of cytopathology specialists locally and at a national level.

Program learning outcomes

The Cytopathology program is structured as a comprehensive one-year training period focused on:

- diagnostic proficiency
- contemporary quality assurance/improvement
- preparatory techniques
- performance of ultrasound- and palpation-guided fine-needle aspirations
- on-site assessment for various sampling modalities
- ancillary testing of cytology specimens (including flow cytometry analysis, cytogenetics, next generation sequencing/other molecular techniques)
- academic research in cytopathology.

Admission requirements

To be eligible, candidates must:

- meet the minimum eligibility requirements for licensure with the College of Physicians and Surgeons of Ontario (CPSO).
- have completed residency training in anatomical or general pathology and must be certified by the Royal College of Physicians and Surgeons of Canada.
- have a valid CPSO Independent Practice License as training will involve work with patients and/or patient records.
- have malpractice insurance with the Canadian Medical Protective Association (CMPA).

Program delivery and assessment

Our program is structured based on graded responsibility and requires the fellow to meet six competencies associated with 15 milestones formulated by the RCPSC Specialty Committee.

The program combines clinical service under the supervision of a group of experienced and dedicated faculty members.

- We deliver a didactic curriculum through various instructive methods including in-person lectures, guided self-study and continuous case-based learning.
- Fellows can hone their skills both as teachers and as scholars through participation in multidisciplinary clinical rounds, academic peer teaching and conference presentations.

Fellows complete four rotations at Sunnybrook Health Sciences Centre and University Health Network. The laboratories at both centres combine their unique practice profiles to ensure a maximum of diversity, exposure, and preparation for high-level independent practice.

We coordinate training through regular meetings of teaching faculty, technical staff, and representatives of LMP which include the fellow(s) and, thereby, provide a mechanism for continuous quality improvement and adjustment of the training experience.

Our program encourages fellows to actively seek out structured cytopathology-related learning experiences outside the program in areas of special interest to them or in areas less comprehensively covered within the program. For example, one fellow completed an elective in pancreato-biliary cytology at the Massachusetts General Hospital in Boston, USA, for dedicated study focused on a novel cytopathology reporting system. The elective was financially supported through a Personal Development Grant provided by the RCPSC.

Fellows complete a training portfolio which is assessed by the AFC Competence Committee and the Program Co-Directors. This portfolio consists of:

- Continuous in-training evaluation
- Structured case log
- In-training examinations (slide-based, digital image-based, oral)
- Documented training assignments (consultation, critical results, quality, health policy etc.)
- Documented ancillary test result analysis and reporting
- Documented contribution to educational peer activities
- Evidence of scholarly activity

Quality of the program



Our program has received consistently positive evaluations by the fellows and significant progress has been made in terms of program structure, electronic documentation, timing of feedback and scholarly output.

The formalized and documented feedback system based on defined entrustable professional activities we introduced, has brought the training closer to a real-time competence-based structure as championed by the RCPSC for specialty medical education across the country and internationally.



Our graduates

Studied	Name	Current Position
2020–2021	Dr. Si Kei Lou	Cytopathologist, Toronto General Hospital, University Health Network
2018–2019	Dr. Blerta Starova	Cytopathologist, William Osler Health Centre, Brampton, ON
2017–2018	Dr. Svetlana Carrigan	Cytopathologist, Orillia Soldiers' Memorial Hospital, Orillia, ON
2016–2017	Dr. Lorna Mirham	Cytopathologist, North York General Hospital, Toronto, ON
2015–2016	Dr. Philippe Stephenson	Cytopathologist, Centre hospitalier de l'Université de Montréal, Montreal, Quebec
2014–2015	Dr. Joerg Schwock	Cytopathologist, Toronto General Hospital, University Health Network and AFC Cytopathology Program Co-Director at LMP.

AFC Program in Transfusion Medicine

At a glance: Transfusion Medicine AFC	
Program length	1–2 years
No. of fellows currently enrolled	3
Program delivery	Series of hospital and Canadian Blood Services (CBS) based rotations
Evaluation methods	In-training assessments, training portfolio
Program Directors	Dr. Wendy Lau
Accreditation	Royal College of Physicians and Surgeons of Canada

8 Areas of Focused Competence

Our Transfusion Medicine Program was previously a Royal College subspecialty program, and the first subspecialty to transition to an Area of Focused Competence (AFC) Diploma program. Our program was reviewed and accredited by the Royal College in 2020.

The program's goal is to train transfusion medicine specialists, medical directors of a hospital transfusion service, or medical directors of a blood centre.

As demand for transfusion medicine expertise in the community grows and positions for transfusion medicine specialists are no longer limited to academic centres, we plan to include a community hospital rotation into the program.

Program learning outcomes

Upon completion of training, our fellows will be competent specialists in Transfusion Medicine, capable of an enhanced practice in this area of focused competence (AFC), within the scope of internal medicine, hematology, pediatrics, hematological pathology, anesthesiology, or general pathology.

We expect them to be able to:

- be knowledgeable about the diagnostic and therapeutic aspects of immunohematology, apheresis, histocompatibility, and related molecular biology and biotechnology.
- manage a medical laboratory and blood centre, including quality, safety, and regulatory aspects.
- ensure the appropriate use of blood.
- ensure the adequacy of blood for the blood system.
- supervise the provision of a safe and effective blood supply.
- supervise the banking and provision of cell therapy products and human tissues for transplantation purposes.
- engage policymakers, other physicians, and other health professionals in transfusion medicine.
- advance the discipline through basic scientific and clinically applied research.

Admission requirements

To be eligible, candidates must have Royal College certification in (or enrolment in a Royal College accredited residency program) in one of:

- Internal Medicine
- Hematology
- Pediatrics
- Hematological Pathology
- Anesthesiology
- General Pathology

Program delivery and assessment

Our program is time-based, and fellows can take one to two years to complete the training requirements and complete the Royal College portfolio milestones. Most spend 18 to 24 months in the program, to take the time to do electives and research.

The hospital rotations are scheduled in a way that allows fellows to progress from a more general transfusion service (general adult hospital), to specialized services (paediatrics, high-risk obstetrics), to the most complex transfusion service (adult hospital with the widest range of services, including bone marrow transplants, solid organ transplants, complex surgeries, hemoglobinopathies etc.).

The blood centre rotations are either spent at Canadian Blood Services (CBS funded fellows) or Hema-Quebec (HQ funded fellows).

The academic portion of the program is delivered nationally by CBS (there are four Transfusion Medicine training programs nationally). CBS also organizes an annual retreat for all fellows across the country with topics centered around leadership and transition to practice. These programs ensure that all transfusion medicine fellows across the country receive similar training, and that graduates can easily practice in a different city/province.

- The first year consist of six rotations, four months at a blood centre and the remaining time rotating through various hospital sites.
- The second year of the program consists of electives and research, and most fellows take the second year to establish research projects that they can continue as staff. Some fellows do a master's program concurrently with the AFC program and they take the second year to complete their master's project.



Fellows are assessed through various methods and submit a completed training portfolio to the RCPSG for assessment:

- Complex transfusion cases
- Antibody lab reports
- In-training examinations (written, oral)
- Documented training assignments (consultation, quality projects etc.)
- Documented contribution to clinical and educational rounds/seminars
- Evidence of scholarly activity

Quality of the program

10
fellows have
completed the
program since 2016

In recent years, the number of applicants applying to the program has been steadily increasing, as reputation of the program grows.

Our fellows consistently provide us with feedback and positive evaluations. We have made progress in improving program structure, electronic documentation, timing of feedback and scholarly output.

Transfusion Medicine is the first AFC program at U of T to use the Competence by Design (CBD) online evaluation system, Elentra. This electronic platform is used to capture all portfolio milestones and allows the Program Director to easily track the fellows' portfolio progress (see more on Elentra in Residency Training Programs, [page 103](#)).

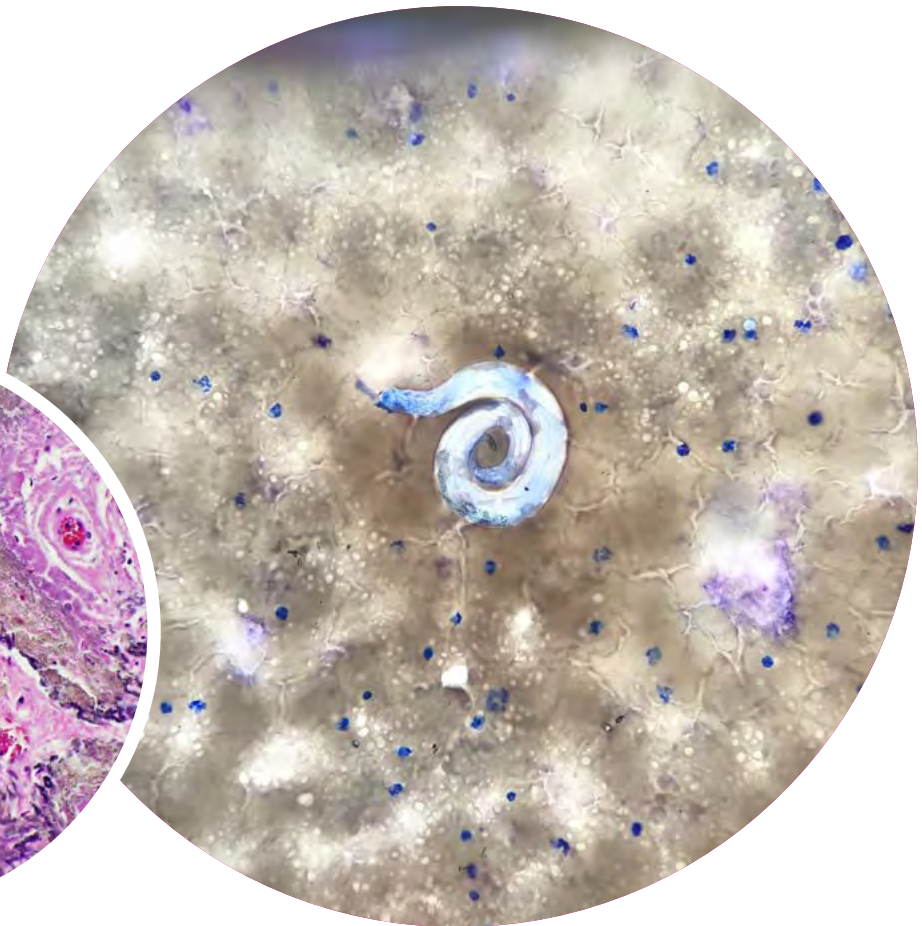
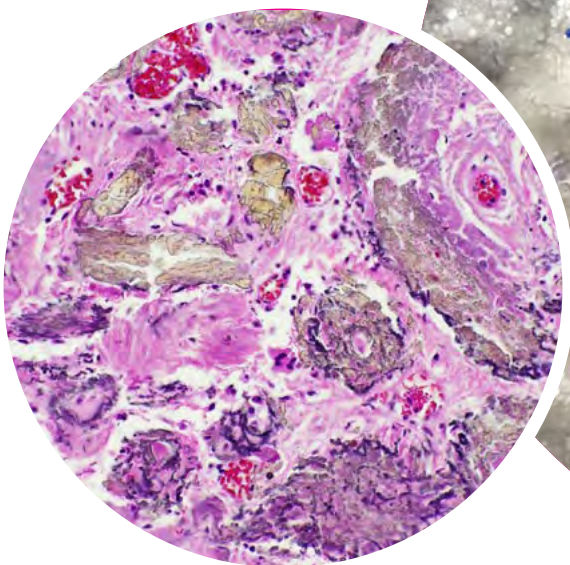



Clinical and Professional Education

Fellowship Training Programs

The LMP Fellowship Program leverages our world-leading expert faculty and broad spectrum of case material at our affiliated teaching sites to provide high quality enhanced post-residency clinical and/or research training in various laboratory medicine disciplines.

Fellowships usually last one year, but may extend to two or more years in length, depending on the trainees' needs and interests. Presently, fellowships may take place at one of six affiliated teaching sites:

1. The University Health Network
2. Mount Sinai Hospital
3. Sunnybrook Health Sciences Centre
4. Trillium Health Partners - Credit Valley site
5. The Hospital for Sick Children
6. Ontario Forensic Pathology Service



Typically, our fellows are supervised by one or two expert faculty members as primary supervisors, but other faculty within their base department often have significant involvement which allows for rich educational and mentorship experiences. In some instances, such as for the highly sought-after Tri-Hospital Gastrointestinal Pathology fellowship, fellows may have the opportunity to work with multiple faculty members at two or more affiliated teaching sites.

Fellowships available vary from year to year depending on available funding and the applicant pool, but include:

- Anatomical Pathology subspecialties
 - » Breast Pathology
 - » Cardiovascular Pathology
 - » Dermatopathology
 - » Endocrine Pathology
 - » Genitourinary Pathology
 - » Gynecological Pathology
 - » Gastrointestinal/Hepatobiliary Pathology
 - » Head and Neck Pathology
 - » Pediatric Pathology
 - » Pulmonary Pathology
 - » Renal Pathology
 - » Soft Tissue and Bone Pathology
 - » Surgical Pathology
- Forensic Pathology
- Hematological Pathology
 - » Pediatric Hematological Pathology
- Medical Microbiology
- Neuropathology

The Fellowship Program is guided by the Fellowship Training Committee (FTC), which prior to 2020 met quarterly, but which has more recently been meeting semi-annually.

The membership is comprised of:

- the Fellowship Director (Dr. David Hwang)
- Fellowship Site Coordinators from each of the affiliated sites
- representatives from Hematopathology, Medical Microbiology, and the Cytopathology Area of Focused Competence Diploma Program
- one to two fellows' representatives who serve for one-year terms, during which they work with the Fellowship Director to plan and execute events and initiatives for the fellows wellness and to bring forward feedback and concerns from fellows at the various sites.
- Chair (ex officio).

Fellows and fellowships

316 fellowship positions since 2013 (average ~35/year)

137 Canadian applicants (43.4%)

179 International trainees (56.6%)

Our fellowships typically fall into two categories:

1. Clinical fellowships

- 87% of fellowships
- Single subspecialty area
- Canadian applicants typically seek additional training in a subspecialty area prior to starting into independent practice
- International applicants are typically practising pathologists seeking subspecialty training related to needs within their home institution
- Participate in clinical research projects related to their subspecialty area
- Participate in educational activities including teaching of residents and medical students rotating through their clinical services, as well as various intradepartmental and multidisciplinary rounds. Fellows at some sites have also had opportunities to participate in teaching medical students as tutors for Case-Based Learning sessions.

2. Research fellowships

- 13% of fellowships
- Focused purely on basic science or translational research with an LMP faculty member, with most being international fellows.
- These fellowships are declining in popularity due to increased registration fees, and as hospital research institutes take a more active role in processing such positions directly.

Regardless of fellowship type, feedback shows the appreciation fellows have for the intense educational and mentorship experience, especially with their supervising faculty members which often extends well beyond the duration of the fellowship term.

Admission requirements

Our clinical fellows must:

- meet the minimum eligibility requirements for licensure with the College of Physicians and Surgeons of Ontario (CPSO).
- have completed residency training in the base lab discipline, base subspecialty, or a complimentary specialty, prior to commencing the fellowship with us.
- have a valid Certificate of Registration for Postgraduate Education from the College of Physicians and Surgeons of Ontario (CPSO) or a valid CPSO Independent Practice License as they may be working with patients and/or patient records.
- have malpractice insurance with the Canadian Medical Protective Association (CMPA).

Research fellows do not have any patient contact during their training so are exempt from many of the requirements above but do need to have a medical degree from a recognized medical school.

Quality of the program

Networking and career development

Fellows typically have access to a range of educational opportunities related to their subspecialty training through their sites and supervisors.

We have focused on providing opportunities for our fellows to network with each other, which has been of particular importance given that the fellowship training sites are geographically dispersed (although these sessions have been suspended during the COVID-19 pandemic). At least once per year, these sessions include faculty members and Department Chiefs from various hospitals across the Greater Toronto Area, as well as sessions focused on various aspects of career development.

Graduated responsibility

From 2014-2019, the FTC and Fellowship Site Coordinators explored and sought to implement various approaches to enhancing graduated responsibility for clinical fellows, particularly the ability for clinical fellows to take on sign-out responsibility for cases without a requirement for consulting their supervising faculty member prior to final reporting of every case.

The College of Physicians and Surgeons (CPSO) and the Canadian Medical Protective Association (CMPA) confirmed that this was acceptable both from regulatory and malpractice coverage perspectives. However, there were varying levels of comfort from different hospital administrations, resulting in some fellowship sites permitting it, and others not.

Feedback from fellows who have been able to take advantage of this 'transition-to-practice' experience has been very positive.

Challenges and opportunities going forward

Funding

Access to funding, and in particular stable funding from year to year, remains an ongoing challenge.

While in recent years, we have endeavored to provide limited support for some research fellowships, fellowships are funded almost exclusively from non-University sources – most often:

- hospital lab departments; and
- sponsoring governments or hospitals (for international and some Canadian fellows).



For most hospital-funded fellowships, the amount of funding available is often not finalized until less than a year before proposed fellowship start dates, making it difficult to compete with high profile American fellowship programs for the best applicants, as American programs typically accept candidates two years prior to the fellowship start date. While some hospital sites have attempted to secure at least some commitments for longer term funding to enable earlier recruitment of top-tier applicants, this remains an ongoing challenge at multiple sites.

Despite the difficulties securing stable funding, however, the various sites comprising our Fellowship Program have, for the most part, continued to experience success securing funds to support fellowships on a year-to-year basis despite an increasingly challenging fiscal environment, accounting for approximately half of all LMP fellowship positions since 2013 (156 of 316, or 49.4%; average of 17.3 funded positions/year).

Prior to 2020, we offered fellowships at St. Michael's Hospital, but these were discontinued due to lack of available ongoing funding.

Beyond traditional hospital-based or academic partnership plan-based sources of funding, funding from philanthropy (e.g. Hospital Foundations; and the G. Raymond Chang Forensic Pathology Fellowship, established in 2015) and industry partners have been of growing importance in recent years. (See Part 2, Global Reach, page 37 for more on the G. Raymond Chang Forensic Pathology Fellowship)

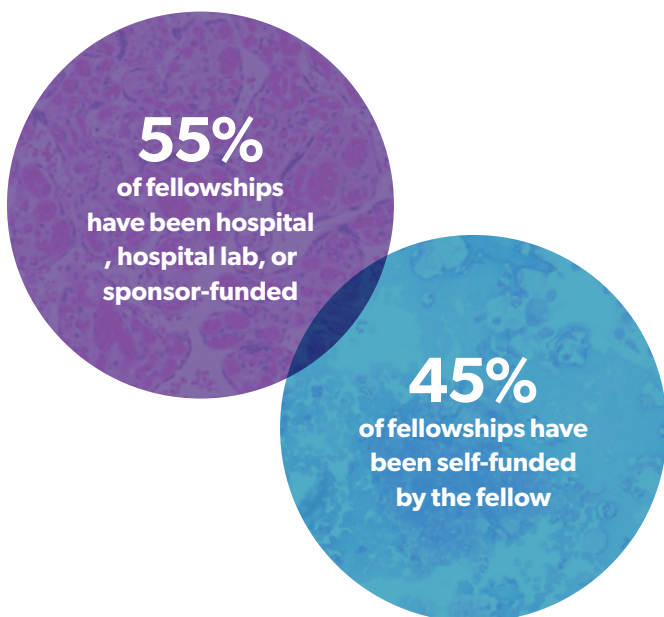

The number of unfunded fellowships demonstrate the ongoing need to identify new and stable sources of funding support for the fellowship program.

Creating community across multiple sites

The LMP Fellowship Program's six sites are dispersed throughout the Greater Toronto Area, making maintenance of cohesion, and deepening of relationships between fellows and the University a perennial challenge.

The focus on networking and career development initiatives noted above have helped, but we need to develop further initiatives to build cohesion among fellows at different geographic sites.

A hybrid approach of the virtual platforms that have come into widespread use during the COVID-19 pandemic, with in person events, should be helpful in this regard going forward.

The shrinking footprint of academic laboratory medicine practice

The past decade has been a challenging one for academic laboratory medicine practice across Canada.

This has been due in part to the difficult fiscal environment facing multiple jurisdictions, resulting in increasing clinical workloads without corresponding increases in staffing, and thus in less time and energy available for academic practice. The increased pressures on academic lab physicians seems to have been reflected in growing numbers of fellows who are entering non-academic practices following their training, while many who have entered academic practice have found it challenging to pursue academic activities in the face of crushing clinical workloads.

While these issues are much larger than the LMP Fellowship Program and need to be addressed more broadly at a system-wide level, now more than ever there is a need for the LMP Fellowship Program to continue training the next generation of academic lab physicians who will lead in transforming the practice of laboratory medicine over the next decade through the implementation of new technologies such as digital pathology, AI algorithms, and advanced imaging modalities.



Clinical and Professional Education

Continuing Professional Development (CPD)

We appointed Dr. Anna Plotkin as Director of Continuing Professional Development in 2017.

The main goal of the Office of CPD is to promote knowledge transfer through an evidence-based approach and to reach as many lab medicine disciplines as possible.

To do this, we created Communities of Interest (COI) around specific topics, for which we achieved Continuing Medical Education (CME) accreditation from the Royal College of Physicians and Surgeons of Canada.

This approach has enabled us to become a national powerful platform for high-quality educational events and the “go-to” networking and learning events for pathologists. The use of the technology (digital slides, virtual meetings) has helped us to broaden our audience internationally.

Our attendees value our thoughtful and well-prepared meetings, the friendly, non-judgmental atmosphere, a great selection of cases, high quality didactic presentations, an opportunity to communicate with key experts in the field and the opportunity to meet colleagues. Our meetings are regular, occurring at least twice a year.

The communities of interest meetings cover not only morphological entities, but also gray areas and deficiencies in these fields. For example, during the last breast COI, one of the community pathologists addressed the issue of counting of mitosis for fibroepithelial lesions of the breast. It was a huge surprise to attendees that within academic institutions in Ontario, different breast pathologists counted mitosis differently.



Distinct attendees and cumulative CME accredited hours reported

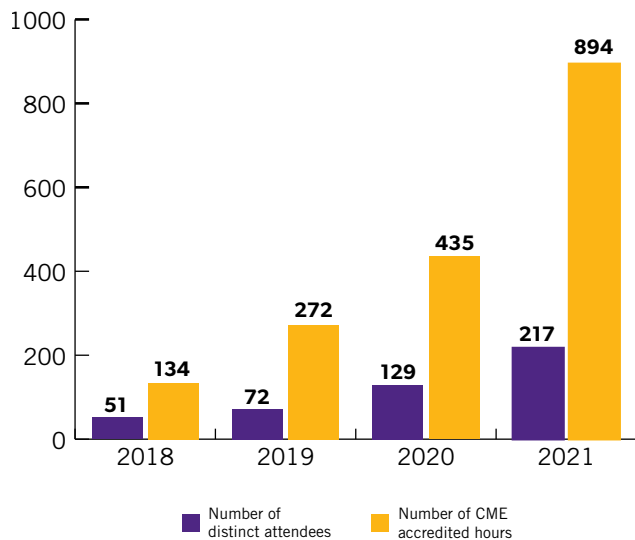

Community of Interest: Breast Pathology

Breast Pathology became our pilot for this new approach and Dr. Plotkin spent significant time canvassing opinions of experts in the field to inform her strategy.

The meetings initially started in person so the community could meet and become comfortable with each other. Creating a “safe space” was vital to encourage sharing of cases and experiences.

The set up included:

- Two expert pathologists in the breast pathology field
- Two organizers (also pathologists)
- An audience consisting of prominent breast pathologists along with the community pathologists dealing with breast pathology in their daily practice.

All participants are encouraged to present cases for discussion that are relevant to everyday practice. At the first meeting, over 15 participants submitted their cases in advance of the meeting.

Feedback

- Very friendly, excellent guest speaker, well organized”
- “The overall format is quite relaxed and allows for some very interesting discussion which is relevant to day-to-day practice.”
- “Thank you very much to all. It was great. I cannot say enough positive about it – very relevant to day-to-day practice!”
- “Multiple cases, engaged audience, respectful interaction with an emphasis on learning.”
- “Great presentations – very practical and concise. Thank you for organizing this meeting. Now with zoom meetings all our pathologists can participate and learn from the best.”

Community of Interest: Gynecological Pathology

We launched a Community of Interest for Gynecological Pathology, adding a keynote speaker and networking sessions to the format.

Community of Interest: quality and patient safety

Our first event of 2020 focused on quality and patient safety, discussing quality indicators and the quality monitoring in surgical pathology with a keynote speaker Yael Kushner Heher from Harvard Medical School.

In 2021, we held a special event on pathology errors that featured a pathologist who underwent an entire practice review, as well as CMPA and CPSO representatives. The event was a tremendous success, with very positive feedback, and was attended by participants from all over Canada and internationally.

Feedback

- “This is a unique event [that gave] an unfiltered honest tour behind these curtains.”
- “This is the first event of such an importance. Everyone wants to know about these issues, but there is no information. This is a real elephant in the room.”
- “This was great. So nice to have a session like this geared toward pathologists specifically. Extremely useful and informative.”
- “Excellent speakers with relevant knowledge and experience. Applicable topics across the entire subspecialty. Practical tips for different situations.”
- “Real world scenarios and practical applications of tools to use when approaching quality in the profession and patient safety.”

Highlights in Pathology research: literature reviews

Another project of the CPD office is “Highlights in Pathology research” to help laboratory professionals navigate the world of constant new information.

Clinical colleagues contribute by summarizing key papers in different subjects of laboratory medicine, from subspecialty-related issues to quality, wellness, and AI. It is still popular (with around 600 page views in the last six months) and updated on a regular basis. These are published on our website.

Revenue generating opportunities in progress

We are currently exploring several avenues of income generation related to continuing professional development.



Clinical Embryology Skills Development Laboratory (CESDL)

We launch our Clinical Embryology Skills Development Laboratory (CESDL) in Fall 2021. As a simulation laboratory, it provides a clinical environment where learners can safely and confidently learn skills before being exposed to patients. The hope is to offer CPD workshops to upskill practicing clinical embryologists from across Canada and internationally in the future so many can benefit from the facility.

We are exploring the potential to use the space for a variety of teaching opportunities from professional development to giving a space for industry sponsored training and courses run by the Canadian Fertility & Andrology Society (CFAS).

Digital Laboratory Medicine Library

The Library (DLM) contains a comprehensive collection of digitized medical images which we currently use primarily in postgraduate medical education.

We are currently working towards making this resource available to working pathologists. On a subscription basis, practicing physicians could use it to study and learn from example cases for CME credits. This could also be used as a resource in courses available to those outside the LMP community.

Certificate in Translational Research

The team leading our Translational Research Program (see MHS in translational research, [page 70](#)) is currently developing a related professional development certificate course, slated for launch in the summer of 2022.

The proposed program is a 13 week not-for-credit Category 3 Certificate in Professional Development. The purpose is to train advanced learners in medical science and health research in the fundamental skills and knowledge domains necessary to effectively acquire translational skills. This is a mentored program intended to run concurrently with the professional research activities of the learners. In this way, learners will have real-world context to the material being presented and will have the ability to apply learnings for immediate impact.





11

Undergraduate Medical Education

The MD Program at U of T has continued to evolve in a manner that de-emphasizes traditional lecture-based learning and discipline-specific courses in favour of self-study, on-line modules, and interdisciplinary themes. This has created challenges in terms of visibility and identity for laboratory medicine in the pre-clerkship phase of the MD program.



How the teaching of pathology has changed in the U of T MD program

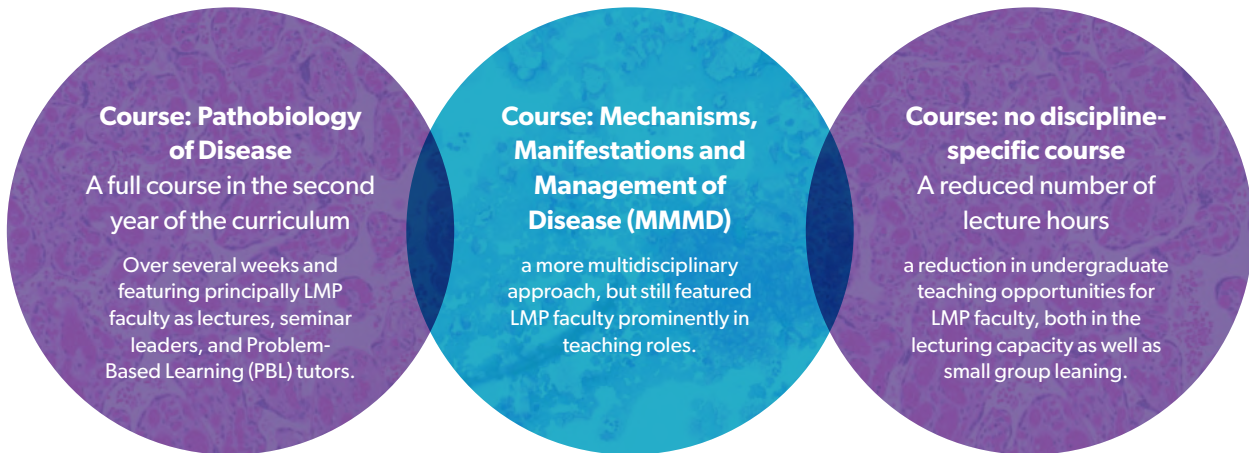

Laboratory medicine continues to lack a presence in the core clerkship rotations. Our strategies to engage medical students therefore focus largely on elective opportunities and extracurricular activities. Some exciting progress has been made in these areas, although the pandemic situation has created unprecedented hurdles.

How we are involved in the undergraduate (MD) curriculum

Introduction to Medicine (ITM) course

Laboratory medicine has a presence in this course, with lab medicine themes integrated into several weeks including genetics, biochemistry, and hematology.

Most pathology teaching takes place in weeks five and six of the first-year curriculum (the inflammation and neoplasia weeks). These weeks are co-led by a pathologist and a clinical hematologist-oncologist and utilize a variety of online modules, small group learning sessions, and lectures to teach basic pathology concepts and how they apply to clinical scenarios.

After the two weeks, we expect medical students to be able to read and understand a pathology report. Forensics and autopsy is also interwoven into the week, and it has become traditional to invite the Chief Forensic Pathologist of Ontario to the final summary lecture, and an open invitation is given to medical students to attend a forensic autopsy.

Concepts, Patients and Communities (CPC) course

Microbiology has a significant footprint in this course in the weeks which focus on infectious disease. The companion Case-Based Learning (CBL) cases on pneumonia and viral hepatitis are well written and consistently are interesting to teach and easy to engage the students in.

Enriching Elective Experiences (EEE)

A component of the 1st and 2nd year program which encourages students to explore different medical specialties by doing half or full day shadowing experiences with physicians.

This has proven to be an excellent opportunity to provide a casual introduction to lab medicine specialties. Students may find lab medicine opportunities in a catalog, but a more common scenario is that they will approach a small group tutor and request a shadowing experience.

Pathology EEE shadowing was also actively promoted through the “Day in the Life of a Pathologist” initiative, where students were specifically invited by the Anatomical Pathology Program Director and the Undergraduate Co-ordinator to be matched to a pathologist in their academy for a single day elective.

The EEE program was temporarily put on hold during the pandemic. As of late July 2021, the University of Toronto and its affiliated hospitals have agreed to re-open the clinical environment to Foundations (pre-clerkship) students who wish to shadow faculty physicians. Students can only undertake a shadowing experience under the Enriching Educational Experiences (EEE) program – both in-person and virtually.

Laboratory Medicine Interest Group (LMIG)

The LMIG has evolved in recent years, receiving official recognition from American Society for Clinical Pathology (ASCP) and the Medical Alumni Association (U of T MedSoc).

The executive of the group typically consists of two second year students and two first year students. Recruitment of new student executives has been fairly seamless over the past three years, as new students are invited to join around the same time when Laboratory Medicine is being introduced in the ITM course. Events in recent years have included microscope sessions focused on concurrent topics in the curriculum, career nights, and special speakers on topics of interest. Once again, the pandemic has been limiting in terms of eliminating the opportunity for in-person events, but senior residents have stepped in to offer a “Case of the month” challenge for the students, which has a devoted following.

Longitudinal Specialty-Focused Case-Based Learning (LSF-CBL)

A new program initiated in the MD Program to try to help fill some of the gaps in career-exploration created by the pandemic measures. In its inaugural year, a second-year student volunteered to be the lead and organized virtual case-based sessions for interested medical students with LMP faculty.

Promotion of LMP to medical students outside U of T

The Royal College began a series of podcasts in 2021 called Specialty Café with the aim of engaging medical students with faculty and residents in particular specialties. Anatomical Pathology was the second specialty chosen for this series, and we were chosen to participate. The Specialty Café episodes are hosted on Spotify and Apple Podcasts and have been promoted by the Royal College to medical students across Canada.

CANPREPP, Canada’s portal for residency program promotion, launched an online events calendar in 2020 to help raise awareness of residency programs. This allows us to showcase our programs to medical students across Canada and ensure they are aware of the various specialty offerings in our department.

Electives and Selectives

This is currently the only significant opportunity for third- and fourth-year students to engage directly in lab medicine, and by definition only occur by the choice of the students.

Given the ever-present pressures on medical students to make career decisions early and choose electives that will boost their CaRMS application, it is critical that we continue to emphasize lab medicine as a career choice in the early years of the MD program.



12

Student support services at Temerty Medicine

A range of support services, delivered through various offices, are available to students at the Temerty Faculty of Medicine. They include:

Undergraduate medical programs

Office of Health Professions Student Affairs

The University of Toronto Office of Health Professions Student Affairs (OHPSA) supports students enrolled in Temerty Medicine, from the Doctor of Medicine, MD/PhD, Medical Radiation Sciences, Physician Assistant, and Occupational Therapy programs. The OHPSA has a multi-faceted range of programs that improve the quality of educational experience provided to students beyond the classroom. Some of the services offered include personal counselling and wellness, career exploration and counselling, and academic coaching.



Financial Assistance

The Student Financial Services Office administers non-repayable grant funding through Temerty Medicine Grant Program, the Temerty Medicine MD Admission Bursaries, and the Enhanced Bursary Program. More than seventy-five percent of the students currently enrolled in the MD program receive some type of non-repayable assistance. MD students also receive a stipend of \$750 per month through the Final Year Medical Student Bursary Fund program for total payment of \$9,000 during the final 12 months of study in the MD program. The bursary program is funded by the Government of Ontario and operated by the Ontario Medical Association.

Other services provided by this office include personal meetings with every incoming Year-1 student to discuss the costs of medical education, budgeting, funding strategies, and any questions or concerns the student might have. Support is provided to run workshops for pre-clerkship students on the topic of How Money Works. The workshops proved very successful, and led to the creation of an online series available to all medical students across Canada.

Graduate and Life Sciences education

Graduate student financial support

In Temerty Medicine, graduate programs offer doctoral-stream students support packages at or above the University of Toronto minimum (i.e. Temerty Faculty of Medicine Harmonized Stipend Agreement). Graduate student support packages are derived from multiple sources including University of Toronto Fellowships, departmental and affiliated hospital/research institute internal awards (i.e., OSOTF awards) and student stipends from supervisors' operating grants.

In addition, students apply for major external competitive studentship awards including, but not limited to, CIHR, NSERC, and independent foundations. Emergency grants and bursaries are also available. More information is available from the School of Graduate Studies.

Graduate student health and wellness

Students, enrolled in a research-stream MSc or PhD program, are eligible to apply for the Leave of Absence (LOA) Stipendiary Fund. When taking a LOA, a student is no longer eligible to receive graduate funding. The LOA Stipendiary Fund provides one-time only financial support to research stream MSc or PhD students who wish to take a LOA due to physical or mental health issues, with the hope they will return healthy and invigorated to continue their graduate studies.

In partnership with the University of Toronto's Office of Health and Wellness, all Temerty Medicine graduate students are eligible to access our on location wellness counsellors as well as other relevant information about supports and services available on campus. This particular service aims to connect students with a counsellor in a timely fashion in order to get the support that they need. Alternatively, graduate students can also access support/wellness services and workshops through the School of Graduate Students Wellness Portal. Registered graduate students also have access to benefits paid via incidental fees.

Benefits include health and dental, travel insurance, and a conference bursary (via UofT Graduate Student Union). More information can be found at the [UTGSU website](#).

Postgraduate medical education

The Office of Resident Wellness was established to help support the well-being of the University of Toronto's Postgraduate Medical Education trainees and to offer assistance to those encountering difficulties during training. One of the roles of the Office of Resident Wellness is to help residents develop the skills needed to maintain their own wellness as a resident and as a practicing physician. There is also an Office of Learner Experience that focuses on learner mistreatment during residency training. This is a confidential service that investigates student-reported incidents.

Anti-Racism and Cultural Diversity Office (ARCDO)

The Anti-Racism and Cultural Diversity Office provides services to support University of Toronto members in fostering intentionally racially diverse and inclusive environments through the advancement of equitable practices, education, and training, and the provision of complaints resolution supports on matters of race, faith, and intersecting identities as guided by the Ontario Human Rights Commission.

Discovery Commons

Discovery Commons is Temerty Medicine's information technology support unit, providing services to students, faculty, and staff. The following are services geared towards the specific needs of MD, PA program, doctoral-stream graduate, and professional master's students:

- Audio Visual including lecture capture, videoconferencing, audience response system support
- Application Support including Learning Portal (Bb), UTORid, MedSIS, GradSIS-Facilities such as drop-in student computer labs, bookable computer labs/electronic classrooms
- Technical support

Enrolment services

Enrolment Services is dedicated to providing quality support and resources that are responsive to the needs of students and graduates (safeguarding the accuracy, integrity, confidentiality and security of students' and graduates' academic records, and providing services relating to registration graduation and beyond). This office works closely with the Curriculum Office, the Academies, and the Office of Health Professions Student Affairs in providing student support.

Through this office, students can obtain information and advice on all faculty and university policies and regulations. Some of the services include: proof of registration or a letter of good standing for students wishing to secure a line of credit with a financial institution, for career sampling, observerships, or when applying for electives at other institutions.

Enrolment Services also provides credentialing services to graduates of the MD program by completing and/or endorsing documentation relating to confirmation of education, confirmation of degree or Dean's letters of support.

The Director of Enrolment Services and Faculty Registrar is a Commissioner of Oaths and provides this service when documents for students or graduates require this level of verification.

Medical Alumni Association

The University of Toronto Medical Alumni Association has been providing support for students and alumni since 1860. For students, they offer financial assistance and awards as well as sponsoring Medical Society events and student support programs. They also support alumni by helping them organize class reunions and stay in touch with each other, and keeping them informed about their alma mater.



Student spaces

Medical Sciences Building (MSB)

David C. Naylor Student Commons

This space is ideal for poster sessions, small seated events, and product information days. It is a high traffic area located at the building's main entrance where students can congregate (booking of space not required).

Ruth Kurdyak Medical Alumni Student Lounge

A home for MD students on campus. This is a modern space with a flexible layout that can be divided into two spaces to fulfill a variety of needs for students. One side can be closed off for activities like meetings (e.g., Daffydil rehearsals or yoga classes); this side of the lounge is also equipped with video conferencing equipment, known as a "looking glass", to help students downtown connect with their colleagues at the Mississauga Academy of Medicine. The other section of the lounge features a kitchen with microwaves and a sink, as well as a place to socialize over a game of foosball or pool.

St. George Campus

All University of Toronto undergraduate and graduate students have access to student services on all three campuses – Mississauga, St. George (downtown Toronto), and Scarborough – regardless of their "home campus."

The services and co-curricular educational opportunities provide a complement to the formal curriculum by engaging and challenging students to reach their full potential as learners, leaders, and citizens.

At the University of Toronto (St. George Campus) these services are organized by Student Life Programs and Services, the academic division registrar offices, and the School of Graduate Studies. All these services combine to support the success of our students from the time they are admitted through degree completion and beyond. Students have access to comprehensive physical and

mental health care on campus including a medical clinic, travel medicine services, immunization, contraception, and sexual health education. Counselling and treatment options for psychological and emotional concerns include psychotherapy, group therapy and pharmacotherapy, as well as specialized assault counselling services provided both by the Health & Wellness centre and the Sexual Violence Prevention and Support Centre. In addition, a large number of wellness programs are provided, such as mindful meditation and workshops on coping skills and stress management.

Housing needs, including off-campus housing listings and resources for students living independently, are met through the Student Housing Service. Coaching and education in the development of key learning skills – from time-management to overcoming exam anxiety – is provided through the Academic Success Centre (ASC). The ASC also partners with faculty to integrate success strategies and support into the curriculum.

Students' career exploration and employment services are provided through a career centre offering resume and interview coaching, workshops, career resources, on and off-campus employment and volunteer listings, job shadowing, and career counselling.

Specialized services are provided for international students (orientation, advising, cross-cultural counselling), students with disabilities (academic accommodations, advising), students with children or other family responsibilities (advising, resources, subsidized childcare), Indigenous students (academic support, financial counselling) and lesbian, gay, bisexual, and transgender students (counselling, referrals, equity outreach, and engagement).

Participation in campus life and experiential learning are facilitated through Hart House (clubs, committees, events), the Centre for Community Partnerships (service learning and volunteer opportunities in community settings), the Multifaith Centre (interfaith dialogue, events), and the Student and Campus Community Development (leadership development, orientation, recognition and support for student groups, activities). Sport and recreational facilities and programs are provided to all students through both Hart House and the Faculty of Kinesiology and Physical Education.



School of Graduate Studies

In addition to the services available to all students, graduate students at the University of Toronto have access to registrarial services and co-curricular programs at the School of Graduate Studies (SGS) that assist students in meeting their academic goals.

Administrative staff at SGS provides registrarial services to graduate students including, but not limited to, recruitment, admission, orientation, registration, fees, program progress, awards/financial assistance, and graduation.

Fully equipped meeting rooms, which can be booked by student groups when not used for Final Oral Examinations, are distributed across two locations – the newly renovated 63 St. George Street (home of SGS Student Services) and 65 St. George Street. Financial advising and wellness counselling services are also available at 63 St. George. Two multi-purpose spaces, provided by SGS, are dedicated to graduate students.

The Grad Room is an accessible space on the St. George campus that provides University of Toronto graduate students with a lounge area and a multi-purpose space for academic, social, and professional graduate student programming.

An additional lounge area for graduate students is available at 63 St. George, which provides graduate students with a quiet place to read, relax, or study.

Grad Room is home to the Graduate Professional Skills Program (GPS). GPS is a non-academic program presented by SGS consisting of a variety of offerings that provide doctoral-stream students a range of opportunities for professional skills development. The program focuses on skills beyond those conventionally learned within a disciplinary program, skills that may be critical to success in the wide range of careers that graduates enter – both within and outside academe. GPS aims to help students communicate effectively, plan and manage their time, be entrepreneurial, understand and apply ethical practices, and work effectively in teams and as leaders.

The Graduate Conflict Resolution Centre (Grad CRC) offers support to the University of Toronto graduate community in taking steps to prevent or resolve conflict. The Grad CRC services for students include peer-to-peer conflict coaching, where students connect confidentially with trained G2G Peer Advisors to talk about options and strategies for addressing a concern and available university supports and resources. The G2G Peer Advisors also facilitate workshops and connect across departments to share tips and strategies for early and effective conflict management. They facilitate connections to campus resources and help students to understand their options in dealing with supervision, escalating a concern, group work, lab/classroom dynamics, or any other challenging graduate school issue.

The Graduate Centre for Academic Communication (GCAC) provides graduate students with advanced training in academic writing and speaking. By emphasizing professional development rather than remediation, GCAC helps students cultivate the ability to diagnose and address the weaknesses in their oral and written work. GCAC offers four types of instruction designed to target the needs of both native and non-native speakers of English: non-credit courses, single-session workshops, individual writing consultations, and writing bootcamps.

“A balanced yet engaging training experience where the graduates feel adequately prepared for independent practice.”

— Forensic Pathology Residents

Back cover image

Muscle in Technicolour by graduate student Aaryn Montgomery-Song

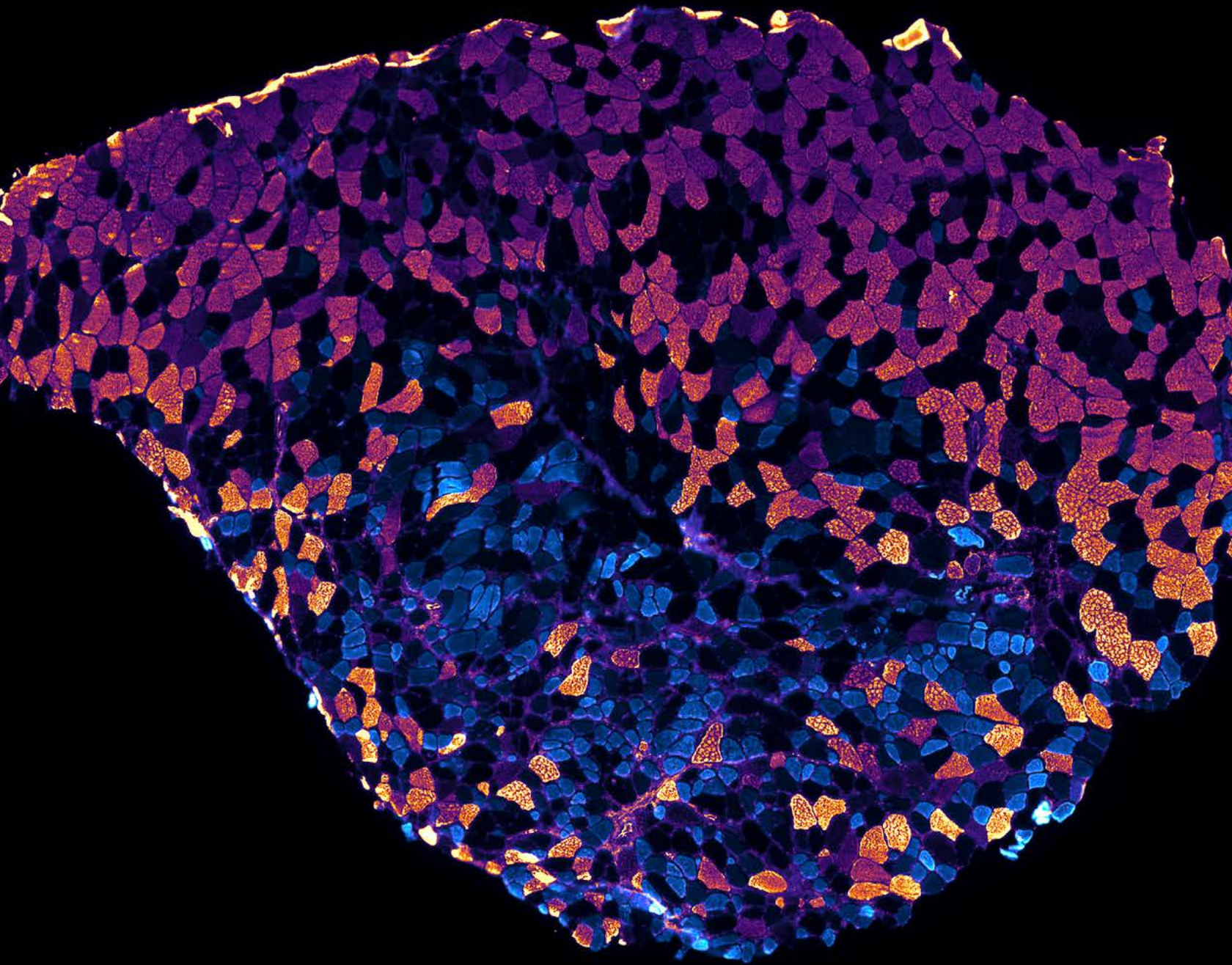

Department of Laboratory Medicine & Pathobiology

University of Toronto, Temerty Faculty of Medicine
1 King's College Circle, 6th Floor
Toronto, Ontario, M5S 1A8, Canada

 @LMP_UofT • Imp.utoronto.ca



Laboratory Medicine & Pathobiology
UNIVERSITY OF TORONTO

**Temerty
Medicine**